

Temperature Compensation for MEAS Pressure Sensors

INTRODUCTION

Advancements in microelectronic technology have pushed silicon sensors not only toward greater sophistication and lower functional cost but also in the direction of higher performance. The major factor affecting high performance applications is temperature dependence of the pressure characteristics.

This technical note describes one method of compensation for temperature dependence. Also note that MEAS also offers factory compensated versions of several sensor products.

INTEGRATED SENSOR DESIGN

In one of the MEAS designs, a mechanical spring element in the form of a rectangular diaphragm, which converts pressure into strain, is integrated into the silicon. To fabricate the diaphragm (Figure 1a), a selective anisotropic etching technique is used which simultaneously produces a large number of diaphragms on a single silicon wafer.

In order to isolate the sensing element from package stress, a Pyrex constraint plate is bonded to the diaphragm plate. If this constraint plate has etched hole, then the diaphragm is subjected to the differential input pressure P_1-P_2 . If the constraint plate has no hole, then the diaphragm is subjected to the differential pressure P_1-P_2 , where P_2 is the pressure at which both plates were sealed together.

To measure the stress in the N-type silicon diaphragm, four P-type resistors (strain gages) are used.

Strain gages result from a selective diffusion of boron into the silicon diaphragm (Figure 1b), a process used in the fabrication of monolithic integrated circuits. The bonding between the four strain gages and the diaphragm is done through the atomic structure of silicon. This type of bonding eliminates creep, which is the major source of instability in metallic or bonded types of strain gage sensors.

The interconnection between strain gages is accomplished with low resistivity P + diffused layers. This approach helps minimize thermal hysteresis effects.

The electrical insulation (passivation) of the diffused resistors and protection of the conductive diaphragm from input media is provided by a thin layer of silicon dioxide grown on both sides of the diaphragm.

Temperature Compensation for MEAS Pressure Sensors

MEAS provides several package styles for mounting the sensors and applying pressure. The HIT and TO-8 products could be mounted to printed circuit boards in applications where dry noncorrosive gases are used as media. The isolated diaphragm (ISO) products may be mounted by O-Ring, welding or standard process fitting in applications where liquids or corrosive media are used. Please see the individual data sheets for media compatibility.

A differential pressure across the diaphragm develops a strain field in such a fashion that a part of the diaphragm is in compression and part is in tension. Two of the strain gages are located in an area of compression and the other two in an area of tension. Electrically they are interconnected into a fully active Wheatstone bridge configuration to maximize the output signal (Figure 1c).

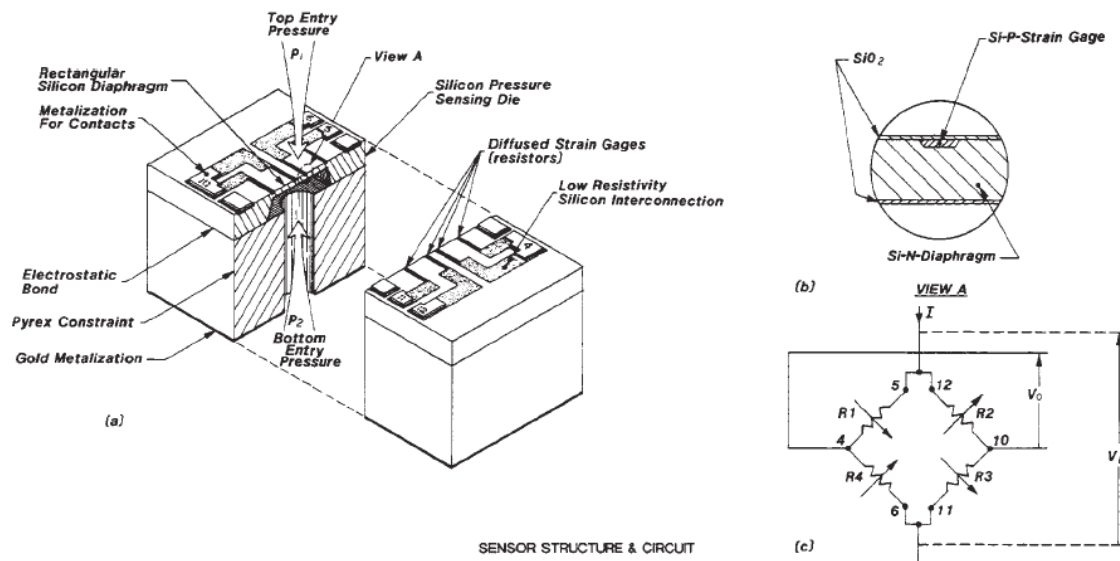

Figure 1 - Sensor Structure and Circuit

TEMPERATURE CHARACTERISTICS OF A SENSOR

Change in ambient temperature results in a corresponding change in three sensor parameters: zero pressure output voltage, pressure sensitivity (span), and bridge resistance. These characteristics are shown for a typical sensor in Figures 2 and 3 where zero and span errors are expressed in percent of span at 25°C.

Temperature Compensation for MEAS Pressure Sensors

Zero pressure output voltage represents the bridge output voltage without any input pressure. Initial polarity of zero at reference temperature usually enforces the slope of the zero change with temperature, e.g. positive offset tends to increase when the temperature increases, but the correlation is not always a strong one

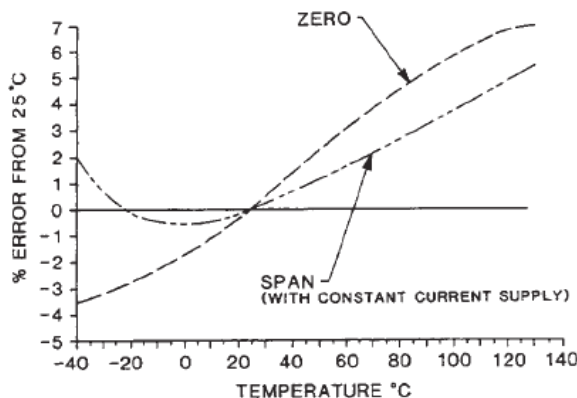

Figure 2 - Temperature Dependence of Zero and Span

Pressure sensitivity is the normalized span in the voltage excitation mode and is expressed as mV (of span) per one volt (of bridge voltage) per one PSI (of applied pressure). It is independent of the type of supply (voltage or current) or pressure range. This sensitivity or gage factor exhibits a negative temperature slope, decreasing with increasing temperature.

The span is defined as the change of the bridge output voltage from full pressure to low pressure. Span change with temperature is a function of the excitation mode.

For a given sensor the span S is a product of normalized pressure sensitivity G , bridge voltage V_b and rated pressure P :

$$S = G \cdot V_b \cdot P \quad [1]$$

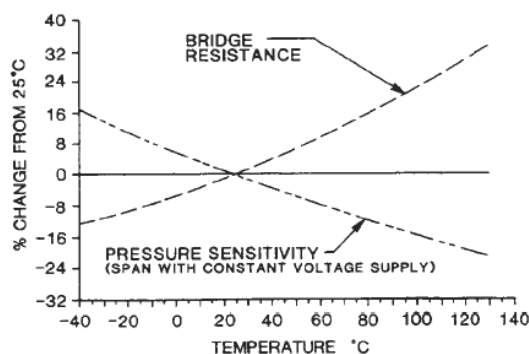

Figure 3 - Temperature Dependence of Bridge Resistance and Pressure Sensitivity

Temperature Compensation for MEAS Pressure Sensors

In the constant voltage excitation mode the span temperature coefficient is negative (Figure 3) and directly proportional to pressure sensitivity. It is typically $-0.21\%/^{\circ}\text{C}$ for MEAS' 5 k process.

In the constant current (I) excitation mode the bridge voltage is proportional to the bridge resistance R_b and span can be expressed as:

$$S = G \cdot R_b \cdot I \cdot P \quad [2]$$

Since bridge resistance changes with temperature, the span temperature error is a superposition of both the pressure sensitivity and the bridge resistance temperature coefficients (Figure 3). For MEAS 5k, process, the bridge resistance temperature coefficient (TCR) prior to compensation is typically $+0.26\%/^{\circ}\text{C}$. Including a negative temperature coefficient of pressure sensitivity (TCG) of $-0.21\%/^{\circ}\text{C}$, a typical constant current span temperature coefficient is about MEAS has optimized several products for other TCR & TCG values. These values are controlled by the ion implant dosages that are used to create strain gage resistors. Please see the individual product data sheets for more information.

For a compensated sensor, which is discussed in more detail in the zero and span sections, the effective TCR is reduced to TCG in amplitude when resistor R_5 is added (Figure 8). The temperature sensitivity of bridge resistance is a key design factor in the temperature compensation of IC Sensor products.

ZERO COMPENSATION

Zero pressure output voltage (offset) compensation includes both initial (25°C) offset compensation and temperature error compensation.

Offset compensation includes resistors R_3 and R_4 (Figure 4). If the offset is positive (+O potential at pin 4 higher than -O potential at pin 10) then insertion of resistor R_4 will bring the offset to zero and resistor R_3 should be shorted. When the offset is negative the reverse is true. These resistors do not change the temperature coefficient of zero in constant current mode (Figure 10).

Temperature Compensation for MEAS Pressure Sensors

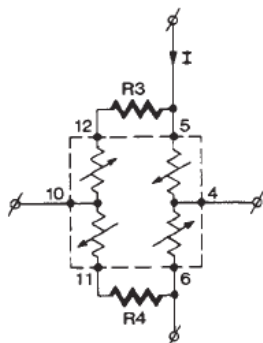

Figure 4 - Offset Compensation

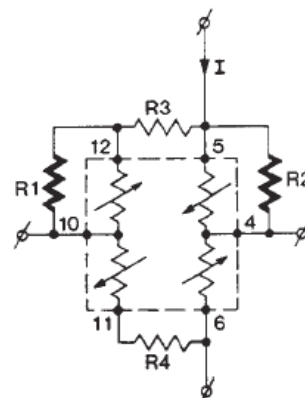

Figure 5 - Offset TC

When the temperature coefficient (TC) of offset is positive (+O potential at pin 4 is increasing faster than -O potential at pin 10), a decrease of this TC may be achieved by a decrease of the effective TC of the strain gage connected between +EX pin 12 and -EX pin 10.

This may be achieved by a parallel connection of a temperature stable resistor R1 (Figure 5). With a negative coefficient of offset voltage, the decrease of the TC of the other arm will be accomplished by resistor R2. Only one of these resistors is used for a given sensor, but both of them affect the initial offset, and the value of resistor R3 or R4 has to compensate for this change.

During standard production testing MEAS uses at minimum 3 test temperatures. Based on measured data the computerized sensor model is developed and a set of simultaneous equations is solved which gives the value of the compensating resistors which bring the offset to zero at reference temperature T_r (Figure 6) and equalize the errors at temperatures T_c and T_h . This error is a function of the temperature nonlinearity of zero. For sensors with perfectly linear temperature coefficient of offset, the errors at T_c and T_h will also be zero.

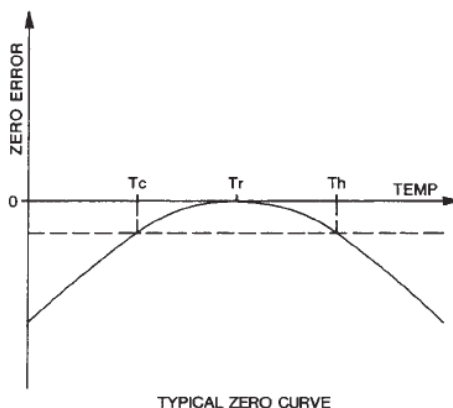

Figure 6 - Typical Zero Curve

Temperature Compensation for MEAS Pressure Sensors

For standard TO-8 products, $T_c = 0^\circ\text{C}$, $T_r = 25^\circ\text{C}$, $T_h = 50^\circ\text{C}$. The typical value of zero pressure output error at both cold and hot temperatures is 0.1% of span. Most of it is due to thermal nonlinearity. In practical applications, inaccuracies in the resistors used for compensation contribute at least this amount of error.

It should be noted that the offset voltage of a bridge is not perfectly proportional to the excitation current. Due to self heating effects the change of excitation current may result in a change of zero pressure output voltage, typically a few hundred micro volts, for a compensated unit.

SPAN TEMPERATURE COMPENSATION

The simplest temperature compensation of span can be achieved by a combination of special wafer processing and constant current excitation. In this mode the span change is a superposition of pressure sensitivity and bridge resistance temperature coefficients. Since these coefficients have different polarities, making them equal in amplitude makes the span internally compensated. The processing required for this type of self compensation limits the cold compensated temperature range due to the nonlinearity of bridge resistance at low temperatures.

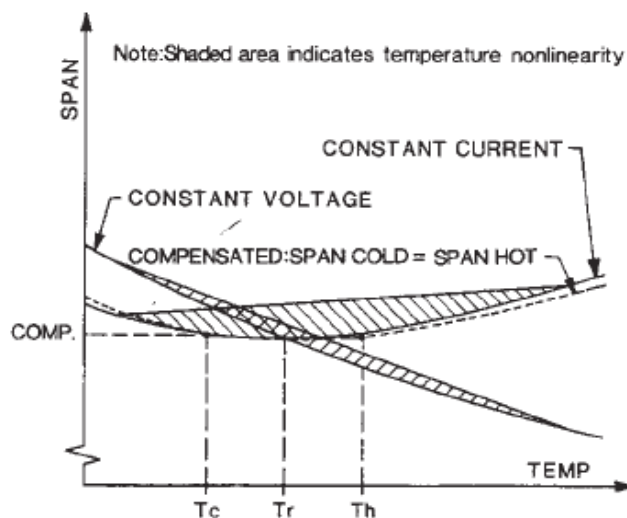

Figure 7 - Span vs. Temperature

MEAS has developed a process which produces a higher value of bridge resistance temperature coefficient (TCR) than the absolute value of pressure sensitivity temperature coefficient (TCG). Thus in constant voltage mode the span will have a negative TC and in the constant current mode the span will have a positive TC (Figure 7). By decreasing the input resistance of the sensor bridge (Figure 8) with resistor R5 in parallel to the bridge for constant current operation (or by increasing the input resistance of the sensor bridge with resistor R5 in series with the bridge for constant voltage operation) the temperature compensation condition can be achieved.

Temperature Compensation for MEAS Pressure Sensors

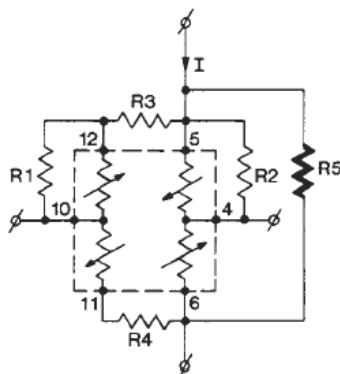

Figure 8 - Span TC

The median optimum value of R5 resistor for MEAS 5 k Ω process is equal to 6.6 times the bridge resistance, or 33 k, at 25°C. For a given excitation level this resistor will decrease the output span. For constant current excitation the median loss of uncompensated sensor output will be only 13%. For the same condition, constant voltage excitation would yield an 87% loss of uncompensated sensor output to achieve temperature compensation. This explains why constant current excitation is recommended for this type of sensor.

Temperature nonlinearity of span in constant current mode (Figure 2) is not as good as for constant voltage (Figure 3). MEAS standard compensating algorithm was designed to provide equal span at temperatures T_c and T_h (0°C and 50°C for standard TO-8 products). Typical constant current mode span error at -40°C is in the range of +3% of span.

The distribution of span error characteristics from unit to unit is much better than the distribution of zero pressure output temperature errors. Implementation of digital correction, based on the deviation from a typical curve and using bridge voltage as a temperature sensor, would yield an additional major improvement.

REQUIRED PERFORMANCE OF COMPENSATING RESISTORS

The effect of both the tolerance and TCR of these resistors on sensor performance is shown in Figures 9 through 11. A 5000 ohm bridge resistance at 25°C with +0.26%/°C temperature coefficient and 15 mV/V/psi pressure sensitivity at 1.5 mA excitation current with -0.21%/°C temperature coefficient is assumed.

The expected resistor ranges are:

R1, R2	100 k to 10 M Ω	Typical:	300 k Ω to 1.5 M
R3, R4	0 to 300 Ω	Typical:	0 to 100 Ω
R5	10 k to 300 k Ω	Typical:	15 k Ω to 100 k Ω

Temperature Compensation for MEAS Pressure Sensors

For the majority of ranges, 1%, 100 ppm/°C resistors such as RN55D or similar are sufficient for this application.

As an example, let's assume that the computer printout calls for:

- R1 = 0.5 MΩ
- R2 = Open
- R3 = 90 Ω
- R4 = Shorted
- R5 = 20 kΩ

The effect of a 1% tolerance for resistor R1 (0.5 MΩ) can be estimated from Figure 9. A 0.19 mV offset change would occur and a 0.06 mV/50°C offset temperature coefficient would be added. A temperature coefficient of 100 ppm/°C for this resistor would contribute an additional 0.12 mV/50°C to the offset temperature coefficient.

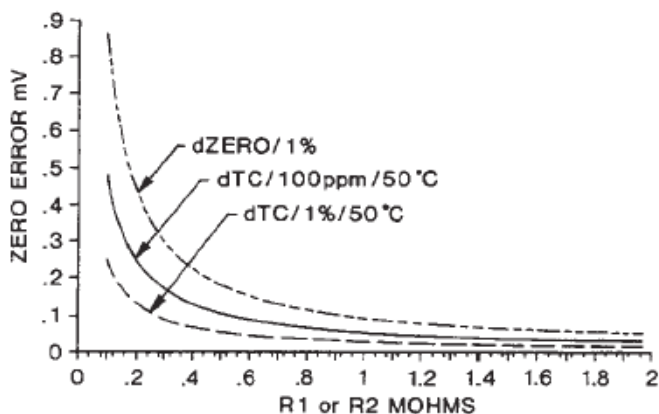

Figure 9 - R1 or R2 Resistor Tolerance

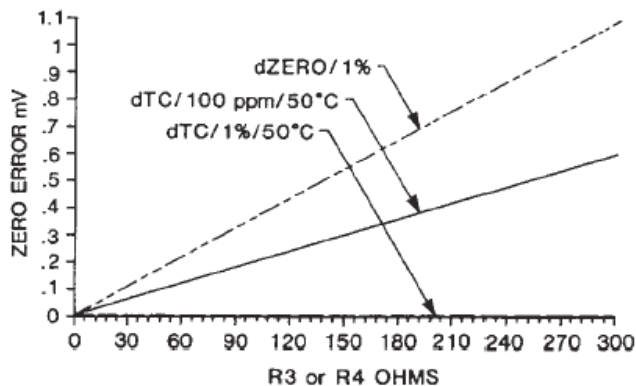

Figure 10 – R3 or R4 Resistor Tolerance

Temperature Compensation for MEAS Pressure Sensors

The effect of resistor R3 (90) can be estimated from Figure 10. The offset would change 0.33 mV for a 1% resistance deviation and 0.17 mV/50°C due to the effect of 100 ppm/°C temperature coefficient. The offset temperature coefficient is not affected by the tolerance of this resistor.

Both of these resistors (parallel: R1 or R2 and series: R3 or R4) affect the span value. Assuming that all strain gages have the same pressure sensitivity, a change of the bridge arm resistance by 1% due to the effect of inserting zero compensation resistors, in turn, changes the span by 0.25%.

Resistor R5 (20 k) does not effect zero compensation. Span error (Figure 11) introduced by a 1% deviation from the calculated value will be equivalent to a 0.19% span change and 0.02%/50°C of additional span temperature coefficient. A temperature coefficient of 100 ppm/°C for resistor R5 would introduce an additional span error of 0.15%/50°C.

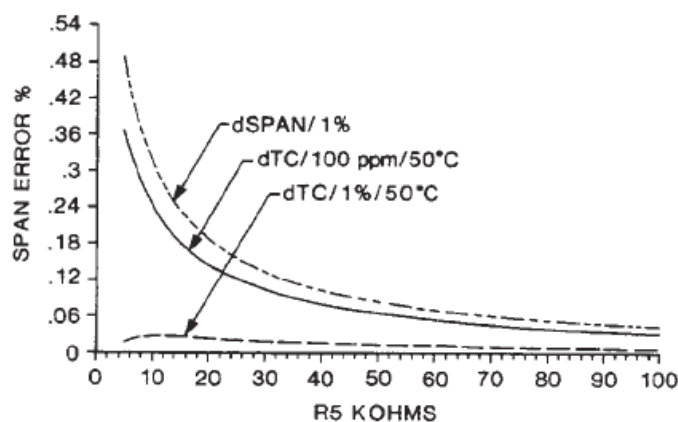

Figure 11. R₅ Resistor Tolerance

To minimize the inventory of external compensating resistor values, it is best to calculate the value of the required resistors when a known error can be tolerated. Assume that a 5 mV offset voltage due to tolerance of R1 or R2 resistor can be tolerated. If 0.5 M (R1) is the starting point, with a 0.19 mV/1% offset sensitivity, a 5 mV limit will be reached after 26 increments of 1% (26) (0.19 mV). Raising 1.01 to the 26th power gives a factor of 1.295 which translates to 648 k. At this resistance value the sensitivity of offset to change in R1 is about 0.16 mV/1%, which is equivalent to 31 increments (5 mV/0.16) of 1%. Raising 1.01 to the 31st power gives a 1.361 factor which translates to 882 k(1.361) (648 k). This value would be stocked along with the 499 k resistor for 5 mV zero increments.

This same approach can be applied to all resistors over the entire range and to all specifications including temperature error. In the example above the worst case assumption was made using the highest error for a given resistance range.

Temperature Compensation for MEAS Pressure Sensors

Using the average error for a given range would be more realistic (0.18 mV/1% over 500 k to 698 k range), but it leaves no room for variations of sensor performance due to processing tolerances.

APPENDIX: CALCULATION OF COMPENSATING RESISTOR VALUES

Values of compensating resistors can be calculated based on the results of pressure-temperature testing. The tests include measurements of output voltage (V) and bridge voltage (E) at two temperatures (T_c and T_h) and two pressures (P1 and P2) with constant current (I) excitation:

	$T = T_c$	$T = T_h$
$P = P_1$	V_{0c}, E_c	V_{0h}, E_h
$P = P_2$	V_{1c}	V_{1h}

Where: V_{0c} , V_{0h} — zero pressure output voltage, cold and hot respectively

V_{1c} , V_{1h} - full scale pressure output voltage, cold and hot respectively

E_c , E_h - bridge voltage, respectively, cold and hot

P_1 , P_2 - input pressure, respectively zero and full scale

T_c , T_h - temperature, respectively cold and hot

ZERO COMPENSATING RESISTORS

To calculate zero compensating resistors lets introduce the variables:

$$A = \frac{V_{0c} + E_c}{I} \quad B = A - \frac{4V_{0c} (V_{0c} + E_c)}{I E_c + 2V_{0c}}$$

$$C = \frac{V_{0h} + E_h}{I} \quad D = C - \frac{4V_{0h} (V_{0h} + E_h)}{I E_h + 2V_{0h}}$$

Temperature Compensation for MEAS Pressure Sensors

A simplified value of offset compensating resistor R_S that includes the correction for offset change due to bridge arm loading by resistor R_1 or R_2 may be calculated now as follows:

$$R_S = \left(A+C - \sqrt{(A-C)^2 - 4 \frac{AB(D-C) - CD(B-A)}{D-B}} \right) \quad [3]$$

The calculated value of resistor R_S may be either positive or negative. The polarity of this value is utilized to define the position of the resistor. As was discussed before, balancing of offset can be realized by R_3 or R_4 resistor (Figure 4).

The truth table for these resistors is as follows:

When $R_S = 0$ then: $R_4 = R_S$, $R_3 = 0$ (shorted) $R_S < 0$ then: $R_3 = R_S$, $R_4 = 0$ (shorted)

The offset temperature slope compensating resistor R_p may then be calculated as follows:

$$R_p = (AB - BR_S)/(B - A + R_S) \quad [4]$$

As before, there are two possible positions of R_p resistor:

When $R_p \geq 0$ then: $R_2 = R_p$, $R_1 = \infty$ (Open)

$R_p < 0$ then: $R_1 = R_p$, $R_2 = \infty$ (Open)

SPAN COMPENSATING RESISTOR

Temperature compensation of span requires one resistor only. Calculating both the span cold (S_c) and hot (S_h) and the bridge resistance cold (R_c) and hot (R_h):

$$S_c = V_{1c} - V_{0c} ; R_c = E / I$$

$$S_h = V_{1h} - V_{0h} ; R_h = E / I$$

We can now calculate the value of span compensating resistor R_5 using the following formula:

$$R_5 = \frac{R_h S_c - R_c S_h}{S_h - S_c} \quad [5]$$

It should be noted that the procedure outlined here does not include the effects of zero compensating resistors on bridge resistance change, but this effect usually is not critical.

Temperature Compensation for MEAS Pressure Sensors

ORDERING INFORMATION

NORTH AMERICA

Measurement Specialties
45738 Northport Loop West
Fremont, CA 94538
Tel: 1-800-767-1888
Fax: 1-510-498-1578
Sales: pfg.cs.amer@meas-spec.com

EUROPE

Measurement Specialties
(Europe), Ltd.
26 Rue des Dames
78340 Les Clayes-sous-Bois, France
Tel: +33 (0) 130 79 33 00
Fax: +33 (0) 134 81 03 59
Sales: pfg.cs.emea@meas-spec.com

ASIA

Measurement Specialties
(China), Ltd.
No. 26 Langshan Road
Shenzhen High-Tech Park (North)
Nanshan District, Shenzhen 518107
China
Tel: +86 755 3330 5088
Fax: +86 755 3330 5099
Sales: pfg.cs.asia@meas-spec.com

The information in this sheet has been carefully reviewed and is believed to be accurate; however, no responsibility is assumed for inaccuracies. Furthermore, this information does not convey to the purchaser of such devices any license under the patent rights to the manufacturer. Measurement Specialties, Inc. reserves the right to make changes without further notice to any product herein. Measurement Specialties, Inc. makes no warranty, representation or guarantee regarding the suitability of its product for any particular purpose, nor does Measurement Specialties, Inc. assume any liability arising out of the application or use of any product or circuit and specifically disclaims any and all liability, including without limitation consequential or incidental damages. Typical parameters can and do vary in different applications. All operating parameters must be validated for each customer application by customer's technical experts. Measurement Specialties, Inc. does not convey any license under its patent rights nor the rights of others.