

2013 Catalog

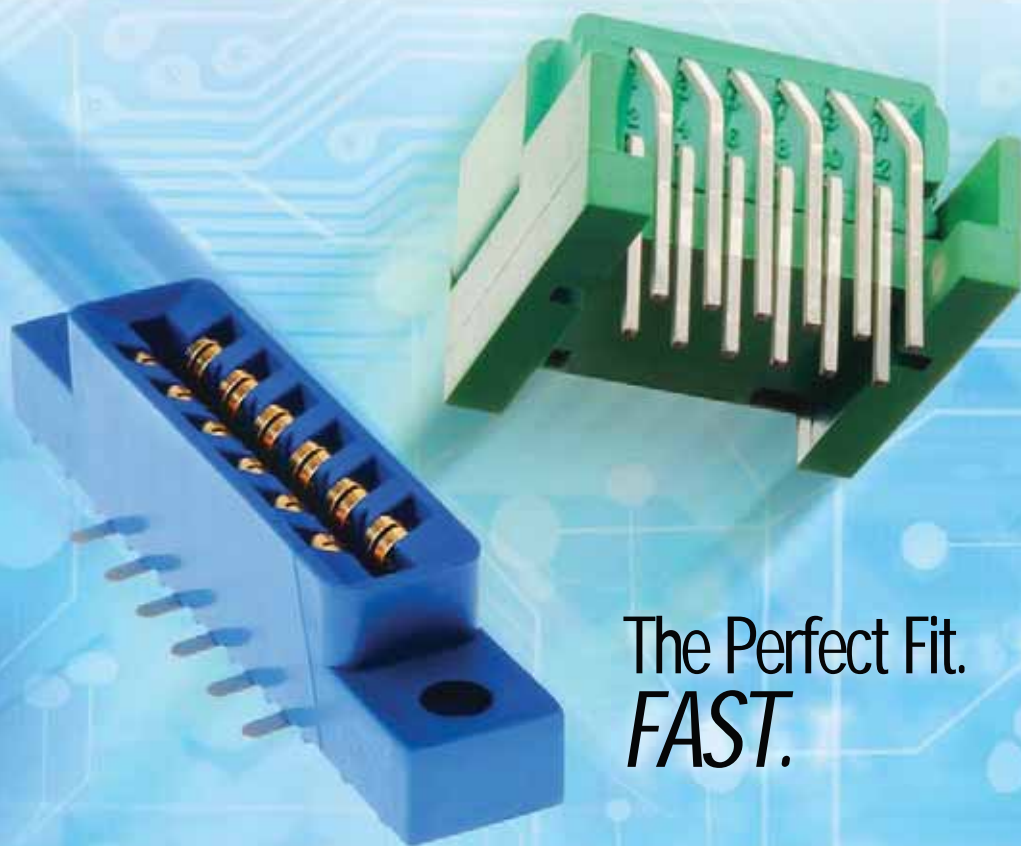

# SULLINS

CONNECTOR SOLUTIONS



The Perfect Fit.  
*FAST.*

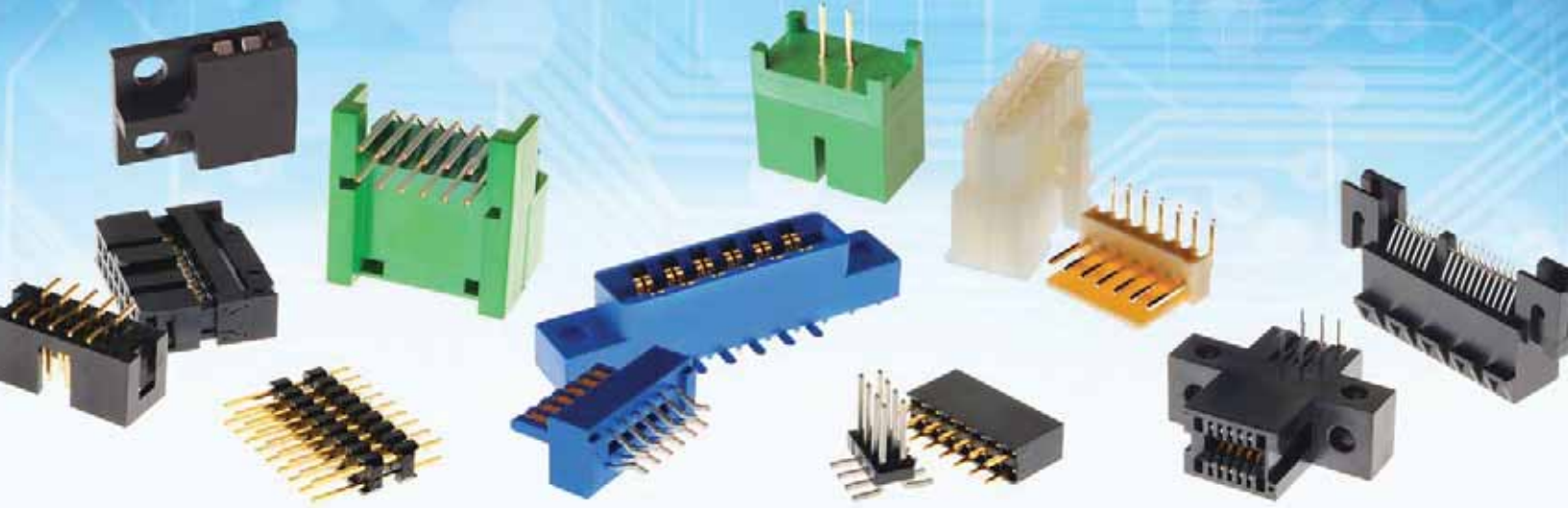



## The Sullins Advantage

### Sullins Builds Solutions

Need a standard connector or a special one built to your specifications? We'll help you get the perfect fit-fast! And we offer more design choices than any competitor out there.

### High Quality Connectors

Our in-house manufacturing facility in California employs the latest production methods and rigorous quality control to deliver reliable, high quality connectors every time.

### Five-day Turnaround

We strive to deliver your order within five business days so you can spend time on more important things.

### Technical Expertise

Sullins' team of applications engineers and technical experts is always ready to help you develop the best solution for your specific application, tackle complex engineering challenges, and provide you the resources you need to bring your project to life.

### RoHS Compliant

Being good to the environment is important to us and our customers. That's why we only use RoHS compliant parts in all our products.

\* While our average delivery time is within five business days, some connector designs with more customized specifications may require additional time to complete.



Order Samples & Products:  
[www.sullincorp.com](http://www.sullincorp.com)  
[info@sullincorp.com](mailto:info@sullincorp.com)  
888.774.3100 toll-free

**USA HQ** | 801 E Mission Rd, San Marcos, CA 92069, USA  
+1-760-744-0125 | fax +1-760-744-6081

**Taiwan** | 10F, NO 268, Fuxing S. Rd., Sec. 2, Taipei, Taiwan  
+886-2-2738-7377 | fax +886-2-2738-3586



## Applications for Sullins Connectors:

- Burn-in and Test Systems
- Electronic Component Testing
- Burn-in Boards
- High Power Device Testers
- Highly Accelerated Life Test
- Semiconductor Testing
- Communications Equipment
- Medical Equipment Instrumentation
- Power Converters and Power Supplies
- Aerospace
- Automotive
- And more...

## The Sullins Advantage

- Five-day Lead Time\*
- Free Samples – Fast!
- High Quality and Reliable Connectors
- Engineering Design and Technical Support
- Connector Experts at Your Service Assist with Specific Project Requirements
- Design and Build Custom Parts to Suit Your Needs
- RoHS Compliance



Order Samples and Products.



# Hi-Temp Connectors

## Features:

### Hi-Temp Male Headers **NEW!**

- Operating temperature range of -65 °C to +150 °C
- Support solder reflow process up to 260 °C peak for 120 seconds max
- Comes in single and dual row configuration with 1 to 36 pins per row
- Available in straight and right angle through-hole, as well as vertical and horizontal surface mount terminations
- Comes in various plating options, including full gold, selective gold, and pure tin

### Hi-Temp Card Edge Connectors

- Operating temperature range of -65 °C to +250 °C
- Available in 1.0mm, 0.050", 0.100", 0.125", and 0.156" contact centers with 2-120 pins per row
- Choices of termination types, including dip solder, wire wrap, right angle, and card extender
- Large selection of mounting styles, including clearance holes, flush mounting, threaded inserts, straddle mount, floating bobbin, and open card slot
- Comes in various plating options, including full gold, selective gold, and pure tin

## Benefits:

- Available in temperatures up to 250 °C for demanding thermal applications
- Features high mating cycle for all our connectors for long-lasting usage
- Large variety of male/female gender, contact centers and termination styles allow maximum design flexibility for various board-to-board applications
- RoHS-compliant and UL94V-0 rated



\*More customized specifications may require additional time to complete.



SULLINS MICROPLASTICS

### Applications for Sullins Test Sockets:

- Burn-in and Test Systems
- Electronic Component Testing
- Burn-in Boards
- High Power Device Testers
- Highly Accelerated Life Test
- Semiconductor Testing
- Communications Equipment
- Medical Equipment Instrumentation
- Power Converters and Power Supplies
- Aerospace
- Automotive
- And more...

### The Sullins Advantage

- Five-day Lead Time\*
- Free Samples – Fast!
- High Quality and Reliable Connectors
- Engineering Design and Technical Support
- Connector Experts at Your Service Assist with Specific Project Requirements
- Design and Build Custom Parts to Suit Your Needs
- RoHS Compliance
- Made in USA



**Order Samples and Products:**  
[www.sullinscorp.com](http://www.sullinscorp.com)  
[info@sullinscorp.com](mailto:info@sullinscorp.com)  
 760.744.0125  
 888.774.3100 toll-free



## Sullins Custom Test Sockets

### Features and Benefits:

- High Temperature, High Current, and Reliability test socket solutions
- Open designs available to replace clamshell type sockets for maximum heat dissipation
- Custom designs for almost any Diode/MOSFET/Transistor
- Low minimum order quantities
- Fastest lead times in the industry on custom designs
- Kelvin design sockets available
- In-House design and custom molding capabilities
- Expert engineering assistance with your design to save you time and money
- Operating temperature ranges of -65°C to +250°C
- Modular tooling for cost effective modifications to current parts
- Full Gold, Selective Gold, and Full Tin plating options available in various thicknesses to provide the best balance of durability cycles and price



[www.sullinscorp.com](http://www.sullinscorp.com)

**USA HQ** | 801 E Mission Rd, San Marcos, CA 92069, USA | +1-760-744-0125 | fax +1-760-744-6081  
**Taiwan** | 10F, No 268, Fuxing S Rd, Sec 2, Taipei, Taiwan | +886-2-2738-7377 | fax +886-2-2738-3586

\*More customized specifications may require additional time to complete.

©2011 Sullins Connector Solutions



SULLINS MICROPLASTICS

### Applications for Sullins Connectors:

- Aircraft Electronic Controls and Radio Communications
- Computing Equipment and Peripherals
- Consumer Electronics and Household Appliances
- Office Equipment
- Automotive Electronics and Accessories
- Casino Gaming Devices
- Medical Devices
- Industry Machinery and Process Control Equipment
- Telecommunication
- Vending Machines
- Burn-in Ovens and Test Equipment
- And more...

### The Sullins Advantage

- Five-day Lead Time\*
- Free Samples - Fast!
- High Quality and Reliable Connectors
- Engineering Design and Technical Support
- Connector Experts at Your Service Assist with Specific Project Requirements
- Design and Build Custom Parts to Suit Your Needs
- RoHS Compliance



#### Order Samples and Products:

www.sullinscorp.com  
info@sullinscorp.com  
760.744.0125  
888.774.3100 toll-free



## Headers and Shunts/Jumpers

### Features and Benefits:

#### Headers

- Available in a large variety of male and female header types for all kinds of applications
- Available in 1.0mm, 0.050", 2.0mm, and 0.100" contact centers
- Various insulator heights to accommodate different application needs
- Available in board stacking configurations
- Choices of termination types include straight and right angle thru hole, as well as surface mount
- Various plating options, including full gold, selective gold, and pure tin
- .100" male headers now available in 150 °C high temperature configuration!

#### Shunts/Jumpers

- Available in 0.050", 2.0mm, 0.100", and 0.200" contact centers
- Various insulator heights to accommodate different application needs
- Various plating options, including full gold and pure tin, to support different mating cycle needs



www.sullinscorp.com

USA HQ | 801 E Mission Rd, San Marcos, CA 92069, USA | +1-760-744-0125 | fax +1-760-744-6081  
Taiwan | 10F, No 268, Fuxing S Rd, Sec 2, Taipei, Taiwan | +886-2-2738-7377 | fax +886-2-2738-3586

\*More customized specifications may require additional time to complete.

©2011 Sullins Connector Solutions



SULLINS MICROPLASTICS

### Applications for Sullins Connectors:

- Burn-in Ovens and Test Equipment
- Electronic Component Testing
- Data Storage Servers
- Communications Equipment
- Networking Equipment
- LED Applications
- Medical Devices
- And more...

### The Sullins Advantage

- Five-day Lead Time\*
- Free Samples – Fast!
- High Quality and Reliable Connectors
- Engineering Design and Technical Support
- Connector Experts at Your Service Assist with Specific Project Requirements
- Design and Build Custom Parts to Suit Your Needs
- RoHS Compliance



**Order Samples and Products:**  
[www.sullinscorp.com](http://www.sullinscorp.com)  
[info@sullinscorp.com](mailto:info@sullinscorp.com)  
 760.744.0125  
 888.774.3100 toll-free



## Dual Edge Connector **NEW!**

### Specifications:

- Now available in 0.100"[2.54mm] with 5-60 pins per row
  - 0.125"[3.18mm] and 0.156"[3.96mm] contact centers, with up to 40 pins per row available upon special request
- Supports an operating temperature of up to 150 °C
- Fits 0.062"[1.57mm]-thick PC boards in both card slots
  - Other board thicknesses available upon special request
- Mounting styles include straddle mount, flush mounting holes, or no mounting
  - Other mounting options available upon special request
- Standard 30u" selective gold plating promotes long lasting usage
  - Other plating options available upon request
- Current rating: 3 Amperes per contact
- Contact resistance: 30 Milliohms max
- Insulation resistance: 5000 Megohms

### Features & Benefits:

- Reliable high temperature board-to-board interconnection up to 150 °C
- Easily replaceable without the need of desoldering
- High signal integrity connector interface for R&D and Life Tests applications
- HTOL, HAST & LTOL and in-line production and burn-in testing compatible
- Superior durability of 500 mating cycles



[www.sullinscorp.com](http://www.sullinscorp.com)

**USA HQ** | 801 E Mission Rd, San Marcos, CA 92069, USA | +1-760-744-0125 | fax +1-760-744-6081  
**Taiwan** | 10F, No 268, Fuxing S Rd, Sec 2, Taipei, Taiwan | +886-2-2738-7377 | fax +886-2-2738-3586

\*More customized specifications may require additional time to complete.

©2011 Sullins Connector Solutions

## Applications for Sullins Connectors:

- Aircraft Electronic Controls and Radio Communications
- Computing Equipment and Peripherals
- Consumer Electronics and Household Appliances
- Office Equipment
- Automotive Electronics and Accessories
- Casino Gaming Devices
- Medical Devices
- Industry Machinery and Process Control Equipment
- Telecommunication
- Vending Machines
- Burn-in Ovens and Test Equipment
- And more...

## The Sullins Advantage

- Five-day Lead Time\*
- Free Samples – Fast!
- High Quality and Reliable Connectors
- Engineering Design and Technical Support
- Connector Experts at Your Service Assist with Specific Project Requirements
- Design and Build Custom Parts to Suit Your Needs
- RoHS Compliance



Order Samples and Products.

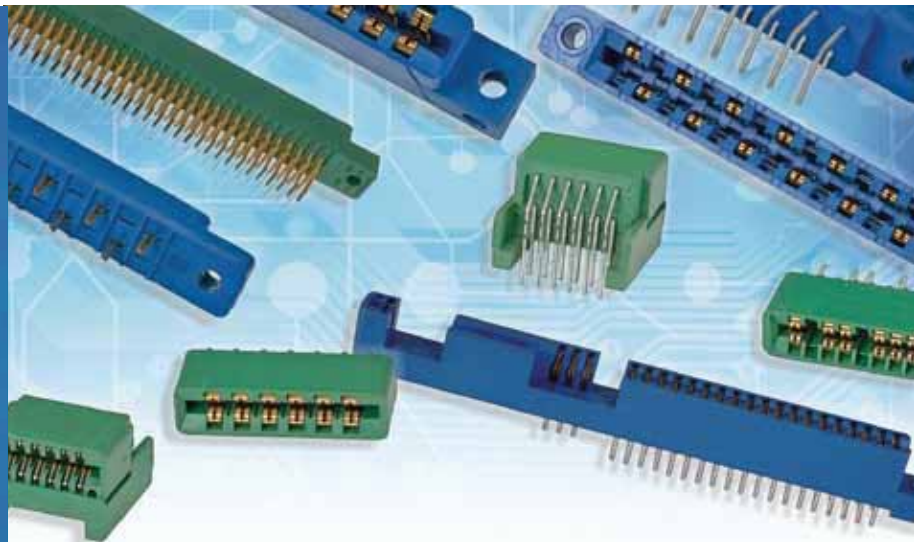

## Custom Connector Solutions

### Features and Benefits:

- Expert engineering team
- In-house design and custom molding capabilities
- Fastest lead time in the industry for custom parts
- Quick change tools allow for small runs within production runs
- Modular tooling allows for quick switch from prototype to production
- Common customization include: molded-in keys, selective loading, special plating, special row spacing
- Modular tooling allows for minimal tooling cost on simple solutions, while competitive for complex solutions
- 3D CAD utilized for design
- Design analysis can lead to cost savings
- Assist with the design up front to save time and money later
- Customer logos or appearance options available

\*More customized specifications may require additional time to complete.



## Product Overview

### Board-to-board

Card Edge  
Connectors



High Density  
Card Edge  
Connectors



Hi-Temp  
Connectors



Headers  
& Shunts



### Board-to-cable

IDC Sockets  
& Dip Plugs



### Board-to-wire

Wire-to-board  
Connectors

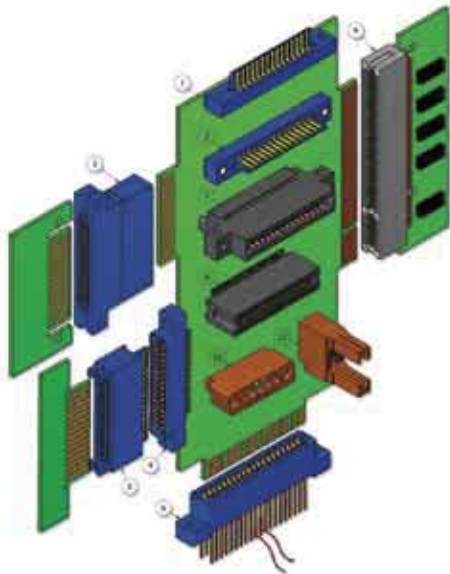

- 1, 2, 3, 4, 5, 6 **CARD EDGE CONNECTOR**
- 7, 8, 9 **HIGH DENSITY CARD EDGE CONNECTOR**
- 10, 11 **CUSTOM CONNECTOR**

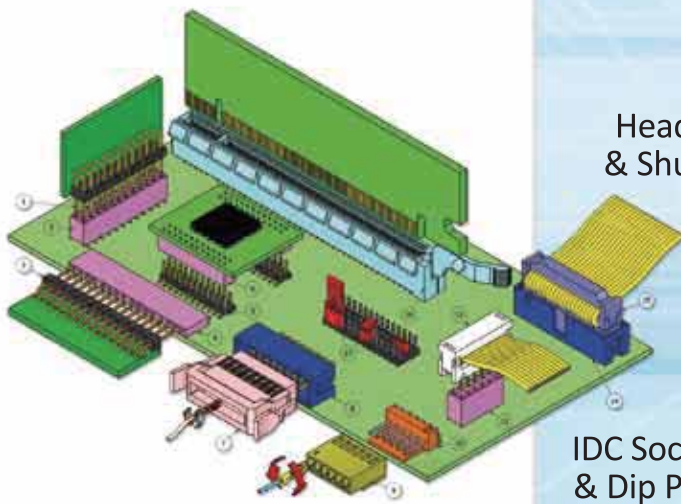

- 1, 3, 5 **MALE HEADER**
- 2, 4, 6, 11 **FEMALE HEADER**
- 7 **CUSTOM WIRE HOUSING & TERMINAL**
- 8 **BOX HEADER**
- 8, 14 **WIRE-TO-BOARD HOUSING & TERMINAL**
- 10 **WAFER HEADER**
- 12 **IDC DIP PLUG**
- 13 **SHUNT**
- 15 **IDC SOCKET**
- 16 **PCI EXPRESS CONNECTOR**





## Sullins' Capabilities

Sullins Connector Solutions is the leader in developing and delivering reliable, cutting-edge connectors for diverse applications and industries worldwide. Headquartered in San Marcos, California, and privately held, Sullins provides the largest selection of 100% RoHS, UL/CUL approved card edge connectors and headers in the industry. Our high-level, high-density and high-temperature connectors are specifically designed for challenging applications used by leading manufacturers and engineers all over the world.



### Quality

- We want to exceed customer expectations at every level of service provided
- Continuous improvement on all aspects of operations
- Soon to be AS9100 certified!
- RoHS compliance on all parts
- Quality control on all raw materials and finished parts based on Statistical Process Control (SPC) methods



### Product Development

- We offer the largest variety of card edge connectors
- Continuous research & development of new connectors to meet new and unique demands
- Dedicated to expand product offering to provide a one-stop shopping experience for customers looking for board level interconnect products



### Speed & Flexibility

- Most orders shipped within 5 business days
- Small orders never a problem
- Same-day response to customer inquiries and Request-for-Quote (RFQ)



### Manufacturing

- In-house molding of various plastic materials, including thermoplastic, high temperature Polyamide and Polyphenylene Sulfide, etc • Full range of precision machining tools to support quick tooling and automated production
- Quick change tools allow for small runs within production runs
- Automated systems to allow efficient product assembly



### Custom Connector Solutions

- In-house design and custom molding capabilities to support quick turn-around time
- Extensive connector design expertise to assist with design analysis and prototype development
- Advanced connector design tools and quick prototyping for design simulation
- Modular tooling allows for quick switch from prototype to production



### Global Sales & Services

- Partnerships with a network of strategically located distributors for more efficient global sales and services
- Asia Pacific Operations established to provide close-range sales support as well as engineering and connector design consultation in the region
- Asia Pacific operations promote logistical convenience by supporting flexible drop-ship options, thus reducing overall lead time.



# TABLE OF CONTENTS

## Sullins Card Edge

GENERAL SPECIFICATIONS .....	6
PART NUMBER OPTIONS .....	7

### High Density Card Edge

#### 1.00 mm [.039" ] Contact Centers

15.49 mm [.610"] Profile, Dip Solder/Card Extender/SMT .....	8
21.84 mm [.860"] Profile, Right Angle .....	10
11.25 mm [.442"] PCI Express Dip Solder .....	12
10.25 mm [.404"] PCI Express Card Extender for Straddle Mount .....	14
19.60 mm [.772"] PCI Express Right Angle .....	16
11.10 mm [.437"] PCI Express SMT with Post .....	18
11.10 mm [.437"] PCI Express Dip Solder with Locking Mechanism .....	20

#### .050" [1.27 mm] Contact Centers

.610" [15.49 mm] Profile, Dip Solder/Card Extender/SMT .....	22
.915" [23.23 mm] Profile, Right Angle .....	24
.610" [15.49 mm] Profile, [MCA] Dip Solder/Card Extender/SMT .....	26
.915" [23.23 mm] Profile, [MCA] Right Angle .....	28
.610" [15.49 mm] Profile, [PCI] Dip Solder/Card Extender/SMT .....	30
.915" [23.23 mm] Profile, [PCI] Right Angle .....	32

### Bi-level Card Edge

#### Capability for .050" [1.27 mm] or .100" [2.54 mm] Contact Centers

High Density, Card Extender, Dip Solder .062" [1.57] or .093" [2.36] Mating PCB .....	34
High Density, Right Angle for .062" [1.57] or .093" [2.36] Mating PCB .....	36

#### Capability for .078" [1.98 mm] or .156" [3.96 mm] Contact Centers

High Density, Right Angle for .062" [1.57] .....	38
--	----

### Dual Edge, .100" [2.54 mm] Contact Centers

### Male Card Edge

.100" [2.54 mm] Contact Centers, Straight & Right Angle Dip Solder Card Extender .....	42
.156" [3.96 mm] Contact Centers, Straight & Right Angle Dip Solder Card Extender .....	44

### Female Card Edge

#### .100" [2.54 mm] Contact Centers

.431" [10.95 mm] Profile, Dip Solder/Eyelet/Right Angle for .062"[1.57] or .031"[0.79] Mating PCB .....	46
.431" [10.95 mm] Profile, Dip Solder/Eyelet/Right Angle for .093"[2.36] Mating PCB .....	48
.610" [15.49 mm] Profile, Dip Solder/Wire Wrap/Right Angle/Card Extender .....	50
.610" [15.49 mm] Profile, .400" Wide Body, Dip Solder/Wire Wrap/Right Angle/Card Extender for .062"[1.57] or .093" [2.36] Mating PCB .....	52
.610" [15.49 mm] Profile, .470" Wide Body, Dip Solder/Wire Wrap/Right Angle for .093"[2.36] or .125"[3.18] Mating PCB ..	54
.610" [15.49 mm] Profile, Dip Solder/ Wire Wrap/Right Angle [ISA] .....	56
.690" [17.52 mm] Profile, Make Before Break Dip Solder/Card Extender/Right Angle .....	58
.560" [14.22 mm] Profile, .400" Wide Body, Double Point Contact, Dip Solder/Wire Wrap/Right Angle/Card Extender .....	60

#### .125" [3.18 mm] Contact Centers

.431" [10.95 mm] Profile, Dip Solder/Eyelet/Right Angle for .062"[1.57] or .031"[0.79] Mating PCB .....	62
.610" [15.49 mm] Profile, Dip Solder/Wire Wrap/Right Angle .....	64
.610" [15.49 mm] Profile, Dip Solder/Wire Wrap/Right Angle for .093"[2.36] or .125"[3.18] Mating PCB .....	66

#### .150" [3.81 mm] Contact Centers

.550" [13.97 mm] Profile, Dip Solder/Wire Wrap .....	68
--	----

#### .156" [3.96 mm] Contact Centers

.431" [10.95 mm] Profile, Dip Solder/Eyelet/Right Angle .....	70
.431" [10.95 mm] Profile, Special Body Configuration, Dip Solder/Eyelet/Right Angle .....	72
.610" [15.49 mm] Profile, Dip Solder/Wire Wrap/Right Angle .....	74
.610" [15.49 mm] Profile, Dip Solder/Wire Wrap/Right Angle for .093"[2.36] or .125"[3.18] Mating PCB .....	76
.720" [18.29 mm] Profile, .045" [1.14 mm] sq./ .031" [.79 mm] x .062" [1.57 mm] Wire Wrap .....	78

### PRESS FIT

.100" [2.54 mm] Contact Centers, 550" or .610" [15.49 mm] Profile .....	80
.156" [3.96 mm] Contact Centers, 550" or .610" [15.49 mm] Profile .....	82



**Sullins Headers**

**1.00 mm [.039"] Contact Centers**

Male Header, Straight/Right Angle/SMT. . . . .	84
Female Header, Straight/SMT . . . . .	86
Male Shrouded Box Header, Straight/SMT . . . . .	88

**.050" [1.27 mm] Contact Centers**

Male Header, Straight/Right Angle/SMT . . . . .	90
Female Header , Straight/Right Angle/SMT . . . . .	92
Female Header, Top/Bottom Entry SMT. . . . .	94
Male Shrouded Box Header, Straight/Right Angle/SMT . . . . .	96
Female Header, SMT with Posts . . . . .	97
Male Shrouded Box Header, Straight/Right Angle/SMT, .100" [2.54 mm] Row Spacing . . . . .	98
IDC Socket, .100" [2.54 mm] Row Spacing, . . . . .	99

**.079" [2.00 mm] Contact Centers**

Male Header, Straight/Right Angle/SMT . . . . .	100
Female Header, Straight/Right Angle/SMT . . . . .	102
Female Header, Top/Bottom Entry SMT. . . . .	104
Male Shrouded Box Header, Straight/Right Angle/SMT . . . . .	106
IDC Socket . . . . .	107

**.100" [2.54 mm] Contact Centers**

Male Breakaway Header, Straight/Right Angle/SMT. . . . .	108
Male Breakaway Header, Straight Thru Hole. . . . .	110
Male Breakaway Header, Right Angle Thru Hole/SMT. . . . .	112
Female Header, Straight/Right Angle/SMT . . . . .	114
Female Header, Top/Bottom Entry SMT. . . . .	116
Male Shrouded Box Header, Straight/Right Angle/SMT . . . . .	118
Female Header, Straight/Right Angle . . . . .	119
IDC Socket, Insulation Displacement With or Without Strain Relief. . . . .	120
IDC Dip Plug, Straight. . . . .	121

**Jumpers**

.050" [1.27 mm] Contact Centers . . . . .	122
.079" [2.00 mm] Contact Centers . . . . .	123
.100" [2.54 mm] Contact Centers . . . . .	124

**Sullins Wafers**

**.079" [2.00 mm] Contact Centers**

SWT201, SWH201, SWR201 Series, Crimp Terminal, Housing, Straight/Right Angle/SMT. . . . .	126
SWT204, SWH204, SWR204 Series, Crimp Terminal, Housing, Straight/Right Angle/SMT . . . . .	130

**.100" [2.54 mm] Contact Centers**

SWT25x Series, Crimp Terminal, Housing, Straight/Right Angle/SMT. . . . .	134
---	-----

**Sullins D-Sub**

SDS100 Series Dip Solder Type . . . . .	138
SDS101 Series Solder Type . . . . .	140
SDS103 Series IDC Type . . . . .	142
SDS104 Series H.D. Right Angle Type . . . . .	144
SDS107 Series Right Angle Type . . . . .	146
SDS108 Series H.D. Right Angle Type . . . . .	150
SDS155 Series High Profile . . . . .	152
SDS160 Series Right Angle. . . . .	154
SDS223 Series Right Angle Slim Type . . . . .	156
SDS224 Series. Right Angle Type . . . . .	158



# Micro Plastics Card Edge

GENERAL SPECIFICATIONS . . . . . 160  
 PART NUMBER OPTIONS . . . . . 161

## Female Card Edge, .100" [2.54 mm] Contact Centers

.431" [10.95 mm] Profile, Dip Solder . . . . . 162  
 .431" [10.95 mm] Profile, Card Extender . . . . . 164  
 .431" [10.95 mm] Profile, Eyelet . . . . . 166  
 .610" [15.49 mm] Profile, Wire Wrap & Dip Solder . . . . . 168  
 .550" [13.90 mm] Profile, .025" [.64 mm] Square Card Extender . . . . . 170  
 .610" [15.49 mm] Profile, Right Angle . . . . . 172  
 .610" [15.49 mm] Profile, Special 18/31 with Barrier, Dip Solder/ Wire Wrap [ISA] . . . . . 174

## Female Card Edge, .125" [3.18 mm] Contact Centers

.431" [10.95 mm] Profile, Dip Solder . . . . . 176  
 .431" [10.95 mm] Profile, Card Extender . . . . . 178  
 .431" [10.95 mm] Profile, Eyelet . . . . . 180  
 .610" [15.49 mm] Profile, Wire Wrap & Dip Solder. . . . . 182  
 .550" [13.90 mm] Profile, .025" [.64 mm] Square Card Extender . . . . . 184  
 .610" [15.49 mm] Profile, Right Angle . . . . . 186

## Female Card Edge, .150" [3.81 mm] Contact Centers

.550" [13.90 mm] Profile, .025" [.64 mm] Square & Round Dip Solder . . . . . 188

## Female Card Edge, .156" [3.96 mm] Contact Centers

.431" [10.95 mm] Profile, Dip Solder . . . . . 190  
 .431" [10.95 mm] Profile, Card Extender. . . . . 192  
 .431" [10.95 mm] Profile, Eyelet . . . . . 194  
 .610" [15.49 mm] Profile, Wire Wrap & Dip Solder . . . . . 196  
 .550" [13.97 mm] Profile, .025" [.64 mm] Square Card Extender . . . . . 198  
 .610" [15.49 mm] Profile, Right Angle . . . . . 200  
 .720" [18.29 mm] Profile, .045" [1.14 mm] Square Wire Wrap . . . . . 202

## Polarizing Keys

Polarizing Keys, In Between Contact & In Contact . . . . . 204

## Part Number Index . . . . . 205



## **FREE SAMPLES — FAST!**

We'll be happy to provide you with free samples for your next project. Our samples usually ship the same day so you can evaluate our products for your next design. It's as simple as calling your sales rep today or using our convenient web sample request.

## **QUICK QUOTES**

Our customer-driven sales team will provide quotes quickly, usually within hours of being contacted. Our aim is to provide you with pricing information fast, so you can place your order and receive it on time.

## **CUSTOM CONNECTORS**

Whether your next design requires a unique connector or just something simple like a molded-in key, Sullins is ready to provide you with a solution to your particular design challenge. We can design a custom connector for your project with little or no additional cost. Call our sales team today and experience the Sullins Advantage. And, since we manufacture most of our connectors in California, we can usually have a custom product ready in just days.

## **FREE CONSULTATION**

Our engineering and technical teams are experts in Card Edge connector and header design. We can help with engineering consultation for a variety of connector applications and a broad range of products. Call us and utilize our technical resources on your next design.

## **QUICK TURNAROUND**

Your project is important to us, so fast delivery is our primary goal. Our average lead times are less than five days, and many orders ship the same day. We strive to provide you with the best quality products in record time. Great products, delivered fast! Our goal is to keep your project on track.

## **EASY PRODUCT SEARCH**

Quickly find a product by part number by using our index found at the end of catalog.



## GENERAL SPECIFICATIONS

### RoHS COMPLIANT



RoHS  
COMPLIANT

All parts are currently manufactured with recommended materials to meet RoHS standards. All contacts have 50u" of nickel underplating, and a large selection of plating options: Pure tin matte, overall gold, or selective gold plating. For complete part number information or operating/processing temperature parameters, visit the RoHS section of our website, or refer to page 7 of this catalog.

### MATERIALS Consult Factory for materials not shown

#### Insulator

- PBT, Valox\*, Thermoplastic Polyester
- PPS, Ryton\*, Polyphenylene Sulfide
- PEEK, Polyetheretherketone
- PA9T, High Temperature Polyamide

#### Contacts

- Phosphor Bronze (Standard)
- Beryllium Copper
- Beryllium Nickel
- Spinodal\*\*
- Brass

### Plating

Plating is Lead Free with Nickel Underplate, offered in Gold (Selective or Overall) and Pure Tin Overall.

**UL/CUL File Number:** E64287

**CAGE CODE:** 54453

**ECCN:** EAR99

**INTERNATIONAL HARMONIZED CODE:** 8536.69.4040

### MECHANICAL

Board Insertion Force: 16 oz Maximum per contact pair using .062"[1.58mm] thick steel test blade  
 Board Withdrawal Force: 1 oz Minimum per contact pair using .062"[1.58mm] thick steel test blade  
 Special Insertion/Withdrawal forces available upon request

### ELECTRICAL

**Insulation Resistance:** 5,000 Mega Ohm

<b>Contact Centers:</b>	.039[1mm]	.050[1.27mm]	.100[2.54mm]	.125[3.18mm]	.150[3.81mm]	.156[3.96mm]
-------------------------	-----------	--------------	--------------	--------------	--------------	--------------

<b>Operating Voltage:</b>	225 VAC	300 VAC	700 VAC	750 VAC	850 VAC	950 VAC
---------------------------	---------	---------	---------	---------	---------	---------

<b>DWV:</b>	675 VAC	900 VAC	2100 VAC	2250 VAC	2550 VAC	2550 VAC
-------------	---------	---------	----------	----------	----------	----------

**Current Rating:** 1 to 5 amp per contact

**Contact Resistance:** 30 milli ohm maximum at rated current

### ENVIRONMENTAL

**Solvent resistance:** Perchloroethylene, Freon 113, Freon 11, Trichloroethylene

<b>Operating Temperature:</b>	PBT	-65°C to +130°C	Phosphor Bronze	-65°C to 125°C
	PPS	-65°C to +200/220°C***	Beryllium Copper	-65°C to 150°C
	PA9T	-65°C to +150°C	Spinodal**	-65°C to +200°C
	PEEK	-65°C to +250°C***	Beryllium Nickel***	-65°C to +300°C

(Continuous temperatures, higher for short duration. Contact Factory for details.)

\* Or equivalent.

\*\* Consult factory for special soldering guidelines

\*\*\* Consult factory for more details



**PART NUMBER OPTIONS**

**MATERIALS (Insulator/Contact)**

E = PBT & Phosphor Bronze  
Operating Temperature: -65°C To +125°C  
Processing Temp: Wave only  
(230°C, 30 Sec.) for Wave solder only

R = PPS & Phosphor Bronze  
Operating Temperature: -65°C To +125°C  
Processing Temperature: 260°C For 120 Sec. Max.

G = PA9T & Phosphor Bronze  
Operating Temperature: -65°C To +125°C  
Processing Temperature: 260° For 20 Sec. Max.

H = PBT & Beryllium Copper  
Operating Temperature: -65°C To +125°C  
Processing Temp: Wave only  
(230°C, 30 Sec.) for Wave solder only

A = PPS & Beryllium Copper  
Operating Temperature: -65°C To +150°C  
Processing Temperature: 260°C For 120 Sec. Max.

J = PA9T & Beryllium Copper  
Operating Temperature: -65°C To +150°C  
Processing Temperature: 260°C For 20 Sec. Max.

M = White PA9T/Beryllium Copper  
Operating Temperature: -65°C To +150°C

F = PPS & Spinodal (Consult Factory)  
Operating Temperature: -65°C To +200°C

C = PPS & Beryllium Nickel (Consult Factory)  
Operating Temperature: -65°C To +200°C  
Processing Temperature: 260°C For 120 Sec. Max.

W = PEEK & Beryllium Nickel (Consult Factory)  
Operating Temperature: -65°C To +250°C

**CONTACT FINISH - RoHS Compliant**

All platings are Lead Free and have .000050" Nickel underplate

	Contact Surface	Termination
B =	.000010" Gold	.000100" Pure Tin, Matte
C =	.000030" Gold	.000100" Pure Tin, Matte
G =	.000010" Gold	.000005" Gold
Y =	.000030" Gold	.000005" Gold
	Contact Surface	Overall Plating
S =	.000010" Gold	.000010" Gold
M =	.000030" Gold	.000010" Gold
E =	.000100" Pure Tin, Matte	.000100" Pure Tin, Matte

Overall Tin available in E, R & G material codes

**CONTACT CENTERS**

E = 1.00 mm [.039"]  
B = .050" [1.27]  
K = .078" [1.98]  
C = .100" [2.54]  
A = .125" [3.18]  
J = .150" [3.84]  
M = .156" [3.96]

**NUMBER OF CONTACT POSITIONS**  
See applicable specification page

**READOUT**

D = Dual  
D = Dual Row/ Crimp to Center for Single Readout  
H = Half Loaded  
M = Male Card Edge

**Registered Trademarks**

Sabic Innovative Plastics: Valox  
Phillips 66: Ryton  
Gardner-Denver Co.: Wire Wrap  
RTP Compounder: PEEK

Sullins Electronics: Zero Lead Time  
Sullins Electronics: Sullins  
Underwriters Labs: UL  
Ametek: Spinodal

**MODIFICATION CODE** (Consult Factory)  
OMIT FOR STANDARD

**MOUNTING STYLE**

H = Clearance Holes, .125" [3.18 mm] Dia  
N = No Mounting  
S = Side Mounting, .125" [3.18 mm] Dia  
I = #4-40 Threaded Insert  
F = Floating Bobbin  
W = .430" Ears, Flush Mounting, .125" [3.18 mm] Dia  
D = .250" Ears, Flush Mounting, .125" [3.18 mm] Dia  
P = Clearance Holes, .142" [3.61 mm] Dia.  
B = Open Card Slot  
X = .430" Ears, Flush Mounting, #4-40 Threaded Insert  
T = .250" Ears, Flush Mounting, #4-40 Threaded Insert  
Q = Straddle Mount  
Z = .250" Ears, Flush, Side Mounting

**TERMINATION TYPE**

**Card Extender**  
HR = .050" & 1mm Contact Centers  
KR, KN, PN, PR = .025" [.64mm] Square Post

**Dip Solder - High Profile**  
RS = .025 [.64] Square Tail, Loop Bellows  
CS, PD, PF, PS, SC = .025" [.64] Square Tail, Hairpin Bellows  
CK, TK = .025" [.64] Round Tail, Loop Bellows  
CT, CW = .015" x .025" Tail, Hairpin Bellows  
HH = .050" & 1mm Contact Centers  
HL, HN = .050" Contact Centers  
KS, KD = .025" [.64mm] Square Post, Cantilever

**Dip Solder - Low Profile**  
SX, SU = Crimp to Center for Single Readout  
RT, RK, RY = .140" [3.56] Row Spacing  
RX, RF, RU, RP = .200" [5.08] Row Spacing  
RJ = .250" [6.3] Row Spacing

**Eyelet**  
RE, TE, SE = Eyelet Tail

**Press Fit**  
.200" [5.08mm] Row Spacing  
JB = .025" [.64] Sq. Post  
JC = .025" [.64] Sq. Post  
JW = .025" [.64] Sq. Post  
JX = .025" [.64] Sq. Post

.100" [2.54mm] Row Spacing  
JF = .025" [.64mm] Sq. Post  
JG = .025" [.64mm] Sq. Post  
JY = .025" [.64mm] Sq. Post  
JZ = .025" [.64mm] Sq. Post

**Right Angle**  
TA, TB, TM = Loop  
CA, CB, CC, PU = Hairpin  
PB, PG, PE, PJ, PP = Hairpin  
KA, KE, KU, KJ = Cantilever  
HA, HB = .050" & 1mm CC  
RA, SA = Full Bellows

**Cantilever**  
ET, EY = .100" CC Low Profile  
YH = .050" CC Thru Hole  
YR = .050" CC Card Extender  
YF = SMT  
YY = Right Angle

**Surface Mount**  
HF = Surface Mount, .050" & 1mm Contact Centers

**Wire Wrap**  
RM = .025" [.64] Square Post, Loop Bellows  
CM, MC, PM = .025" [.64] Square Post, Hairpin Bellows  
KK = .031" [.79] x .062" [1.58] Post  
KL = .031" [.79] x .062" [1.58] Post Twisted 90°  
KM = .025" [.64] Square Post, Cantilever  
WW = .045" [1.14] Square Po

**Bi-Level**  
LR = Card Extender  
LT = Dip Solder  
KB = Right Angle

**Male Card Edge**  
MW, MS = Dip Solder  
MR, MN = Card Extender  
MM = Wire Wrap  
MA, MV, MB = Right Angle

**Dual Edge**  
SL = Dual Edge

Specifications are subject to change without notice.



**1.00 mm [.039"] Contact Centers, 15.49 mm [.610"] Insulator Height  
Dip Solder/Card Extender/SMT**

**SPECIFICATIONS**

- Accommodates 1.57 mm  $\pm$  .20 [.062"  $\pm$  .008"] PC board
- PPS or PA9T insulator
- Molded-in key available
- 1 amp current rating per contact
- Highly reliable high cycle hairpin bellow contacts
- UL Flammability Rating: 94V-0

**READOUT**

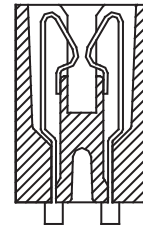

DUAL (D)

**TERMINATION TYPE**

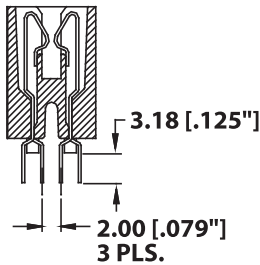

STAGGERED DIP SOLDER (HH)

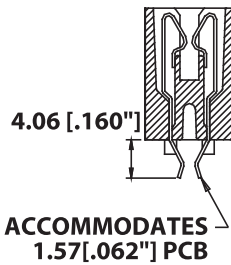

CARD EXTENDER (HR)

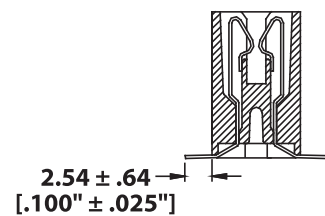

SURFACE MOUNT (HF)

**PCB LAYOUT**

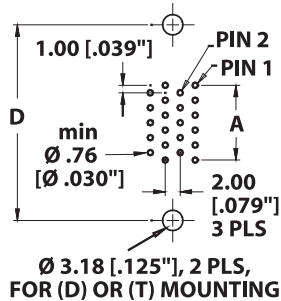

CONNECTOR SIDE (HH)

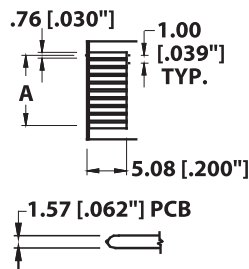

SOLDER END (HR)

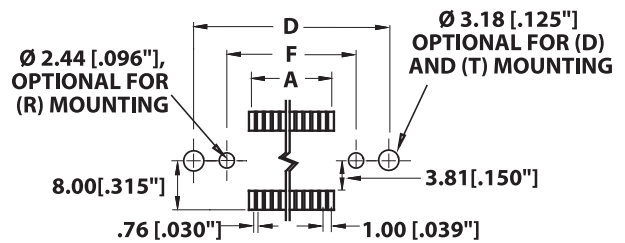

CONNECTOR SIDE (HF)

**MOUNTING STYLE**

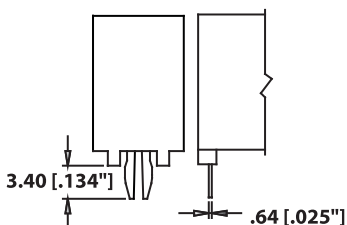

BOARD LOCK (R)  
(with no mounting ears)



NO MOUNTING EARS (N)

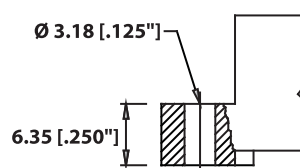

FLUSH MOUNTING (D)

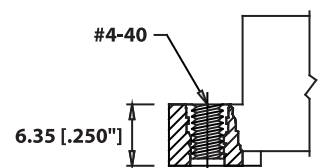

THREADED INSERT (T)



**1.00 mm [.039"] Contact Centers, 15.49 mm [.610"] Insulator Height  
Dip Solder/Card Extender/SMT**

Sullins High Density

**PART NUMBER OPTIONS**

**MATERIALS (INSULATOR/CONTACT)**

- G = PA9T/Phosphor Bronze
- R = PPS/Phosphor Bronze
- J = PA9T/Beryllium Copper
- A = PPS/Beryllium Copper

**CONTACT FINISH - RoHS Compliant**

All platings are Lead Free and have .000050" Nickel underplate  
**Contact Surface Termination**

- B = .000010" Gold .000100" Pure Tin, Matte
- C = .000030" Gold .000100" Pure Tin, Matte

**CONTACT CENTERS**

- E = 1.00 mm [.039"]

**G B E 50 D HH D - Sxxx**

**MODIFICATION CODE (Consult Factory)**  
OMIT FOR STANDARD

**MOUNTING STYLE (Opposite Page)**

- D = Flush Mounting
- N = No Mounting
- R = Metal Board Lock
- T = Flush Mounting, #4-40 Threaded Insert

**TERMINATION TYPE (Opposite Page)**

- HH = Staggered Dip Solder
- HR = Card Extender
- HF = Surface Mount

**READOUT (Opposite Page)**

D = Dual

**NUMBER OF CONTACT POSITIONS**

See Chart Below

**DIMENSIONS**

Dimensions in [ ] are in Inches, all others are in Millimeters

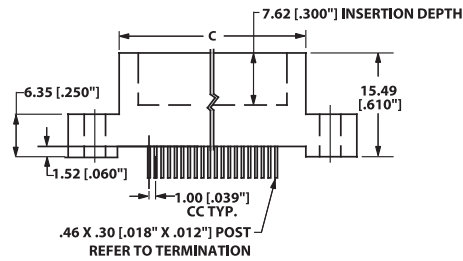
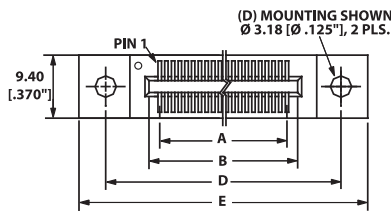

POSITIONS/ CONTACTS	MILLIMETERS						[INCHES]					
	A	B	C	D	E	F	A	B	C	D	E	F
	±.13	±.13	±.38	±.25	±.51	±.25	±.005	±.005	±.015	±.010	±.020	±.010
02/04*	1.00	4.32	9.89	17.15	25.13	4.66	0.039	0.170	0.389	0.675	0.989	0.183
03/06*	2.00	5.32	10.89	18.15	26.13	5.66	0.079	0.210	0.429	0.715	1.029	0.223
04/08*	3.00	6.32	11.89	19.15	27.13	6.66	0.118	0.249	0.468	0.754	1.068	0.262
05/10	4.00	7.32	12.89	20.15	28.13	7.66	0.157	0.288	0.507	0.793	1.107	0.301
06/12*	5.00	8.32	13.89	21.15	29.13	8.66	0.197	0.328	0.547	0.833	1.147	0.341
07/14*	6.00	9.32	14.89	22.15	30.13	9.66	0.236	0.367	0.586	0.872	1.186	0.380
08/16 *	7.00	10.32	15.89	23.15	31.13	10.66	0.276	0.407	0.626	0.912	1.226	0.420
09/18*	8.00	11.32	16.89	24.15	32.13	11.66	0.315	0.446	0.665	0.951	1.265	0.459
10/20	9.00	12.32	17.89	25.15	33.13	12.66	0.354	0.485	0.704	0.990	1.304	0.498
11/22*	10.00	13.32	18.89	26.15	34.13	13.66	0.394	0.525	0.744	1.030	1.344	0.538
12/24*	11.00	14.32	19.89	27.15	35.13	14.66	0.433	0.564	0.783	1.069	1.383	0.577
13/26*	12.00	15.32	20.89	28.15	36.13	15.66	0.472	0.603	0.822	1.108	1.422	0.616
14/28*	13.00	16.32	21.89	29.15	37.13	16.66	0.512	0.643	0.862	1.148	1.462	0.656
15/30	14.00	17.32	22.89	30.15	38.13	17.66	0.551	0.682	0.901	1.187	1.501	0.695
16/32*	15.00	18.32	23.89	31.15	39.13	18.66	0.591	0.722	0.941	1.227	1.541	0.735
17/34*	16.00	19.32	24.89	32.15	40.13	19.66	0.630	0.761	0.980	1.266	1.580	0.774
18/36*	17.00	20.32	25.89	33.15	41.13	20.66	0.669	0.800	1.019	1.305	1.619	0.813
19/38*	18.00	21.32	26.89	34.15	42.13	21.66	0.709	0.840	1.059	1.345	1.659	0.853
20/40	19.00	22.32	27.89	35.15	43.13	22.66	0.748	0.879	1.098	1.384	1.698	0.892
21/42*	20.00	23.32	28.89	36.15	44.13	23.66	0.787	0.918	1.137	1.423	1.737	0.931
22/44*	21.00	24.32	29.89	37.15	45.13	24.66	0.827	0.958	1.177	1.463	1.777	0.971
23/46*	22.00	25.32	30.89	38.15	46.13	25.66	0.866	0.997	1.216	1.502	1.816	1.010
24/48*	23.00	26.32	31.89	39.15	47.13	26.66	0.906	1.037	1.256	1.542	1.856	1.050
25/50*	24.00	27.32	32.89	40.15	48.13	27.66	0.945	1.076	1.295	1.581	1.895	1.089
26/52*	25.00	28.32	33.89	41.15	49.13	28.66	0.984	1.115	1.334	1.620	1.934	1.128
27/54*	26.00	29.32	34.89	42.15	50.13	29.66	1.024	1.155	1.374	1.660	1.974	1.168
28/56*	27.00	30.32	35.89	43.15	51.13	30.66	1.063	1.194	1.413	1.699	2.013	1.207
29/58*	28.00	31.32	36.89	44.15	52.13	31.66	1.102	1.233	1.452	1.738	2.052	1.246
30/60*	29.00	32.32	37.89	45.15	53.13	32.66	1.142	1.273	1.492	1.778	2.092	1.286
31/62*	30.00	33.32	38.89	46.15	54.13	33.66	1.181	1.312	1.531	1.817	2.131	1.325
32/64*	31.00	34.32	39.89	47.15	55.13	34.66	1.220	1.351	1.570	1.856	2.170	1.364
33/66*	32.00	35.32	40.89	48.15	56.13	35.66	1.260	1.391	1.610	1.896	2.210	1.404
34/68*	33.00	36.32	41.89	49.15	57.13	36.66	1.299	1.430	1.649	1.935	2.249	1.443
35/70*	34.00	37.32	42.89	50.15	58.13	37.66	1.339	1.470	1.689	1.975	2.289	1.483
36/72*	35.00	38.32	43.89	51.15	59.13	38.66	1.378	1.509	1.728	2.014	2.328	1.522
37/74*	36.00	39.32	44.89	52.15	60.13	39.66	1.417	1.548	1.767	2.053	2.367	1.561
38/76*	37.00	40.32	45.89	53.15	61.13	40.66	1.457	1.588	1.807	2.093	2.407	1.601
39/78*	38.00	41.32	46.89	54.15	62.13	41.66	1.496	1.627	1.846	2.132	2.446	1.640
40/80	39.00	42.32	47.89	55.15	63.13	42.66	1.535	1.666	1.885	2.171	2.485	1.679
41/82*	40.00	43.32	48.89	56.15	64.13	43.66	1.575	1.706	1.925	2.211	2.525	1.719
42/84*	41.00	44.32	49.89	57.15	65.13	44.66	1.614	1.745	1.964	2.250	2.564	1.758
43/86*	42.00	45.32	50.89	58.15	66.13	45.66	1.654	1.785	2.004	2.290	2.604	1.798
44/88*	43.00	46.32	51.89	59.15	67.13	46.66	1.693	1.824	2.043	2.329	2.643	1.837
45/90*	44.00	47.32	52.89	60.15	68.13	47.66	1.732	1.863	2.082	2.368	2.682	1.876
46/92*	45.00	48.32	53.89	61.15	69.13	48.66	1.772	1.903	2.122	2.408	2.722	1.916
47/94*	46.00	49.32	54.89	62.15	70.13	49.66	1.811	1.942	2.161	2.447	2.761	1.955
48/96*	47.00	50.32	55.89	63.15	71.13	50.66	1.850	1.981	2.200	2.486	2.800	1.994
49/98*	48.00	51.32	56.89	64.15	72.13	51.66	1.890	2.021	2.240	2.526	2.840	2.034
50/100	49.00	52.32	57.89	65.15	73.13	52.66	1.929	2.060	2.279	2.565	2.879	2.073

\* Consult Factory For Availability.



# High Density Card Edge

**1.00 mm [.039"] Contact Centers, 21.84 mm [.860"] Insulator Height  
Right Angle**

## SPECIFICATIONS

- Accommodates 1.57 mm ± .20 [.062" ± .008"] PC board
- PA9T or PPS insulator
- Molded-in key available
- High reliability/high cycle hairpin bellows contact
- 1 amp current rating per contact
- 150 grams normal force minimum
- UL Flammability Rating: 94V-0

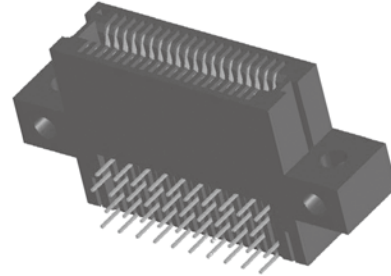

### READOUT

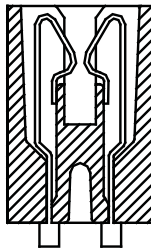

DUAL (D)

### TERMINATION TYPE

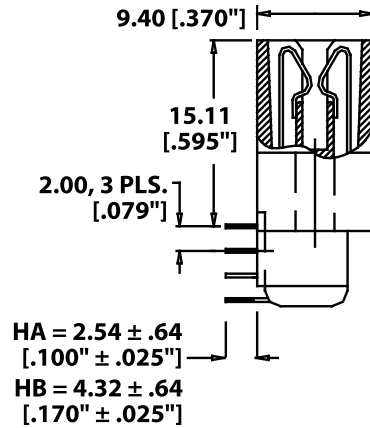

### PCB LAYOUT

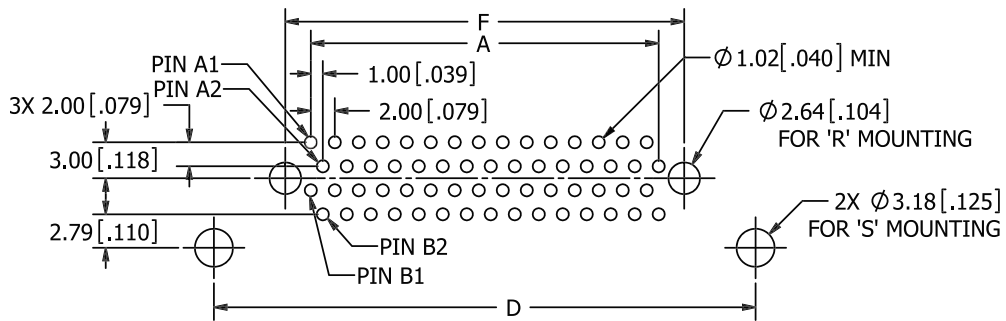

### MOUNTING STYLE

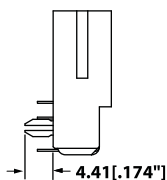

BOARD LOCK (R)  
(with no mounting ears)

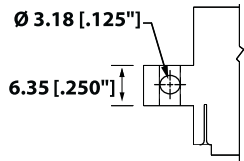

SIDE MOUNTING (S)

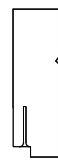

NO MOUNTING EARS (N)

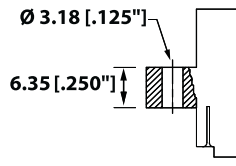

CLEARANCE HOLE (D)

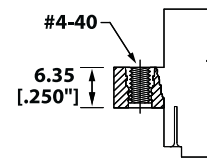

THREADED INSERT (T)

**1.00 mm [.039"] Contact Centers, 21.84 mm [.860"] Insulator Height  
Right Angle**

**PART NUMBER OPTIONS**

**MATERIALS (INSULATOR/CONTACT)**

- G = PA9T/Phosphor Bronze
- R = PPS/Phosphor Bronze
- J = PA9T/Beryllium Copper
- A = PPS/Beryllium Copper

**CONTACT FINISH - RoHS Compliant**

All platings are Lead Free and have .000050" Nickel underplate

**Contact Surface Termination**

- B = .000010" Gold .000100" Pure Tin, Matte
- C = .000030" Gold .000100" Pure Tin, Matte

**CONTACT CENTERS**

- E = 1mm [.039"]

**NUMBER OF CONTACT POSITIONS**

See Chart Below

**MODIFICATION CODE (Consult Factory)**  
OMIT FOR STANDARD

**MOUNTING STYLE (Opposite Page)**

- D = Flush Mounting
- N = No Mounting
- R = Metal Board Lock
- S = Side Mounting
- T = Flush Mounting -Threaded Insert

**TERMINATION TYPE (Opposite Page)**

- HA = .100" [2.54] Tail Length
- HB = .170" [4.32] Tail Length

**READOUT (Opposite Page)**

- D = Dual

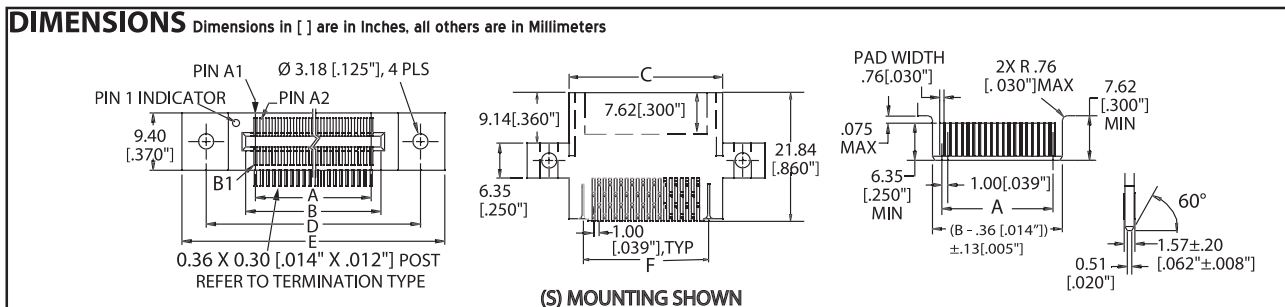

POSITIONS/ CONTACTS	MILLIMETERS						[INCHES]					
	A	B	C	D	E	F	A	B	C	D	E	F
	±.13	±.13	±.38	±.25	±.51	±.25	±.005	±.005	±.015	±.010	±.020	±.010
02/04*	1.00	4.32	9.89	17.15	25.13	5.25	0.039	0.170	0.389	0.675	0.989	0.207
03/06*	2.00	5.32	10.89	18.15	26.13	6.25	0.079	0.210	0.429	0.715	1.029	0.246
04/08*	3.00	6.32	11.89	19.15	27.13	7.25	0.118	0.249	0.468	0.754	1.068	0.285
05/10	4.00	7.32	12.89	20.15	28.13	8.25	0.157	0.288	0.507	0.793	1.107	0.325
06/12*	5.00	8.32	13.89	21.15	29.13	9.25	0.197	0.328	0.547	0.833	1.147	0.364
07/14*	6.00	9.32	14.89	22.15	30.13	10.25	0.236	0.367	0.586	0.872	1.186	0.404
08/16*	7.00	10.32	15.89	23.15	31.13	11.25	0.276	0.407	0.626	0.912	1.226	0.443
09/18*	8.00	11.32	16.89	24.15	32.13	12.25	0.315	0.446	0.665	0.951	1.265	0.482
10/20	9.00	12.32	17.89	25.15	33.13	13.25	0.354	0.485	0.704	0.990	1.304	0.522
11/22*	10.00	13.32	18.89	26.15	34.13	14.25	0.394	0.525	0.744	1.030	1.344	0.561
12/24*	11.00	14.32	19.89	27.15	35.13	15.25	0.433	0.564	0.783	1.069	1.383	0.600
13/26*	12.00	15.32	20.89	28.15	36.13	16.25	0.472	0.603	0.822	1.108	1.422	0.640
14/28*	13.00	16.32	21.89	29.15	37.13	17.25	0.512	0.643	0.862	1.148	1.462	0.679
15/30	14.00	17.32	22.89	30.15	38.13	18.25	0.551	0.682	0.901	1.187	1.501	0.719
16/32*	15.00	18.32	23.89	31.15	39.13	19.25	0.591	0.722	0.941	1.227	1.541	0.758
17/34*	16.00	19.32	24.89	32.15	40.13	20.25	0.630	0.761	0.980	1.266	1.580	0.797
18/36*	17.00	20.32	25.89	33.15	41.13	21.25	0.669	0.800	1.019	1.305	1.619	0.837
19/38*	18.00	21.32	26.89	34.15	42.13	22.25	0.709	0.840	1.059	1.345	1.659	0.876
20/40	19.00	22.32	27.89	35.15	43.13	23.25	0.748	0.879	1.098	1.384	1.698	0.915
21/42*	20.00	23.32	28.89	36.15	44.13	24.25	0.787	0.918	1.137	1.423	1.737	0.955
22/44*	21.00	24.32	29.89	37.15	45.13	25.25	0.827	0.958	1.177	1.463	1.777	0.994
23/46*	22.00	25.32	30.89	38.15	46.13	26.25	0.866	0.997	1.216	1.502	1.816	1.033
24/48*	23.00	26.32	31.89	39.15	47.13	27.25	0.906	1.037	1.256	1.542	1.856	1.073
25/50*	24.00	27.32	32.89	40.15	48.13	28.25	0.945	1.076	1.295	1.581	1.895	1.112
26/52*	25.00	28.32	33.89	41.15	49.13	29.25	0.984	1.115	1.334	1.620	1.934	1.152
27/54*	26.00	29.32	34.89	42.15	50.13	30.25	1.024	1.155	1.374	1.660	1.974	1.191
28/56*	27.00	30.32	35.89	43.15	51.13	31.25	1.063	1.194	1.413	1.699	2.013	1.230
29/58*	28.00	31.32	36.89	44.15	52.13	32.25	1.102	1.233	1.452	1.738	2.052	1.270
30/60*	29.00	32.32	37.89	45.15	53.13	33.25	1.142	1.273	1.492	1.778	2.092	1.309
31/62*	30.00	33.32	38.89	46.15	54.13	34.25	1.181	1.312	1.531	1.817	2.131	1.348
32/64*	31.00	34.32	39.89	47.15	55.13	35.25	1.220	1.351	1.570	1.856	2.170	1.388
33/66	32.00	35.32	40.89	48.15	56.13	36.25	1.260	1.391	1.610	1.896	2.210	1.427
34/68*	33.00	36.32	41.89	49.15	57.13	37.25	1.299	1.430	1.649	1.935	2.249	1.467
35/70*	34.00	37.32	42.89	50.15	58.13	38.25	1.339	1.470	1.689	1.975	2.289	1.506
36/72*	35.00	38.32	43.89	51.15	59.13	39.25	1.378	1.509	1.728	2.014	2.328	1.545
37/74*	36.00	39.32	44.89	52.15	60.13	40.25	1.417	1.548	1.767	2.053	2.367	1.585
38/76*	37.00	40.32	45.89	53.15	61.13	41.25	1.457	1.588	1.807	2.093	2.407	1.624
39/78*	38.00	41.32	46.89	54.15	62.13	42.25	1.496	1.627	1.846	2.132	2.446	1.663
40/80	39.00	42.32	47.89	55.15	63.13	43.25	1.535	1.666	1.885	2.171	2.485	1.703
41/82*	40.00	43.32	48.89	56.15	64.13	44.25	1.575	1.706	1.925	2.211	2.525	1.742
42/84*	41.00	44.32	49.89	57.15	65.13	45.25	1.614	1.745	1.964	2.250	2.564	1.781
43/86*	42.00	45.32	50.89	58.15	66.13	46.25	1.654	1.785	2.004	2.290	2.604	1.821
44/88*	43.00	46.32	51.89	59.15	67.13	47.25	1.693	1.824	2.043	2.329	2.643	1.860
45/90*	44.00	47.32	52.89	60.15	68.13	48.25	1.732	1.863	2.082	2.368	2.682	1.900
46/92*	45.00	48.32	53.89	61.15	69.13	49.25	1.772	1.903	2.122	2.408	2.722	1.939
47/94*	46.00	49.32	54.89	62.15	70.13	50.25	1.811	1.942	2.161	2.447	2.761	1.978
48/96*	47.00	50.32	55.89	63.15	71.13	51.25	1.850	1.981	2.200	2.486	2.800	2.018
49/98*	48.00	51.32	56.89	64.15	72.13	52.25	1.890	2.021	2.240	2.526	2.840	2.057
50/100	49.00	52.32	57.89	65.15	73.13	53.25	1.929	2.060	2.279	2.565	2.879	2.096

\* Consult Factory For Availability.



Sullins High Density

**DIMENSIONS** Dimensions in [ ] are in Inches, all others are in Millimeters

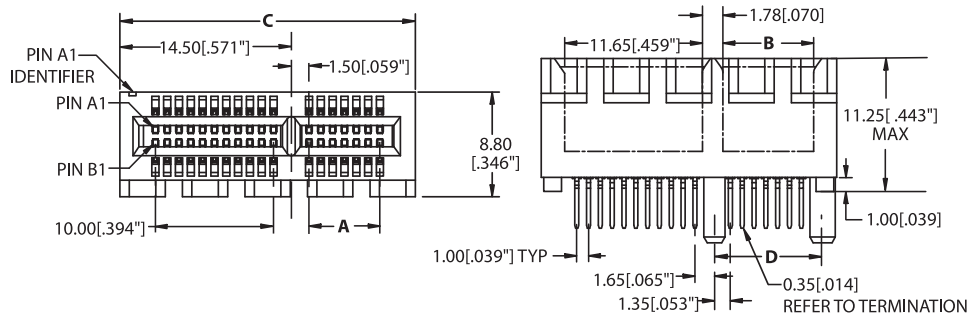

**18/36, 32/64, 49/98, 82/164 POSITION, STAGGERED DIP SOLDER (HH)**

POSITIONS/ CONTACTS	MILLIMETERS				[INCHES]			
	A ± 0.10	B ± 0.15	C ± 0.23	D ± 0.20	A ± 0.004"	B ± 0.006"	C ± 0.009"	D ± 0.008"
18/36	6.00	7.65	25.00	9.15	0.236	0.301	0.984	0.360
32/64	20.00	21.65	39.00	23.15	0.787	0.852	1.535	0.911
49/98	37.00	38.65	56.00	40.15	1.457	1.522	2.205	1.581
82/164	70.00	71.65	89.00	73.15	2.756	2.821	3.504	2.880

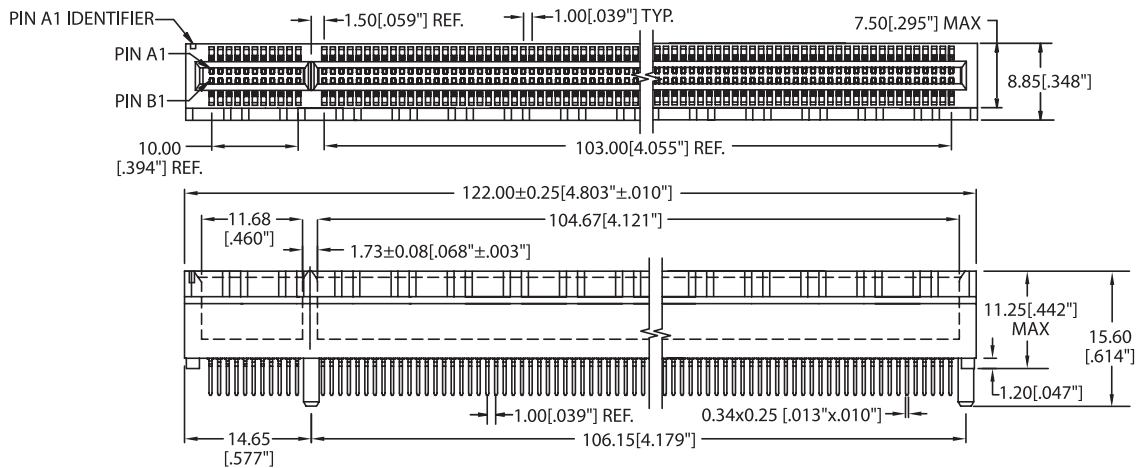

**115/230 POSITION, STAGGERED DIP SOLDER (HH)**

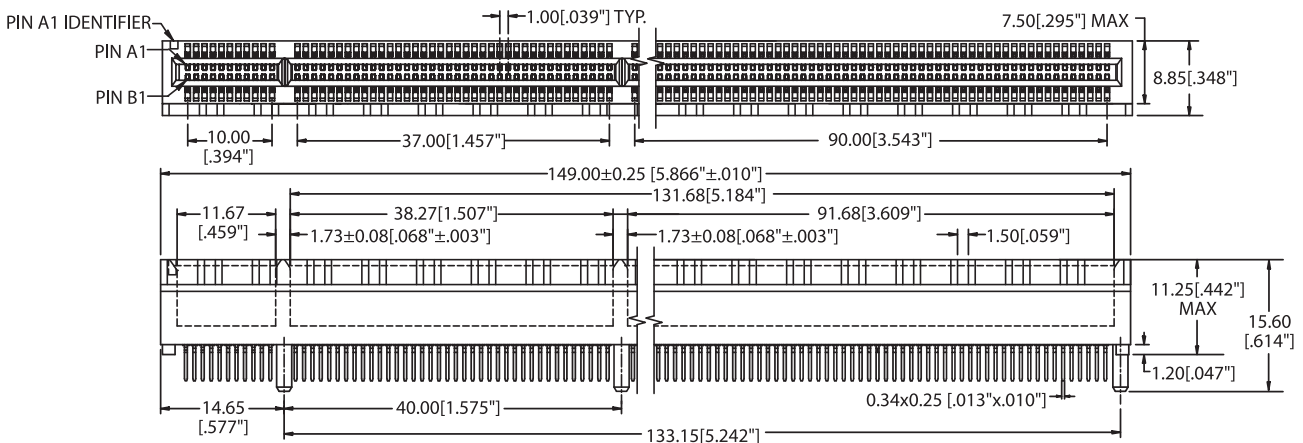

**140/280 POSITION, STAGGERED DIP SOLDER (HH)**



**PART NUMBER OPTIONS**

**MATERIALS (INSULATOR/CONTACT)** ——— **N B E 18 D HH N -T9 2 1**

N = Nylon/Phosphor Bronze

**CONTACT FINISH - RoHS Compliant**

**All platings are Lead Free and have .000050" Nickel underplate**

	<b>Contact Surface</b>	<b>Termination</b>
B =	.000010" Gold	.000100" Pure Tin, Matte
C =	.000030" Gold	.000100" Pure Tin, Matte
W =	Gold Flash	.000100" Pure Tin, Matte

**CONTACT CENTERS** ———

E = 1mm [.039"]

**NUMBER OF CONTACT POSITIONS** ———

18, 32, 49, 82, 115, 140

**COLOR**  
1 = Black  
Consult factory for alternate colors

**TAIL LENGTH**  
1 = 2.30mm [.122"] (18, 32, 49, 82, 115)  
(140 Position, not available)  
2 = 2.54mm [.100"] (115 & 140)  
3 = 3.10mm [.122"] (18, 32, 49, 82, 115)  
3.00mm [.118"] (140 Position)

**MOUNTING STYLE**  
N = No Mounting

**TERMINATION TYPE**  
HH = Staggered Dip Solder

**READOUT**  
D = Dual

Operating & Processing Temperature: Consult Factory

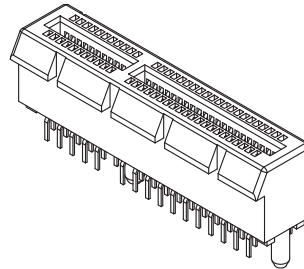

**SPECIFICATIONS**

- All PCI Express parts meet the latest PCI Express specifications
- Supports 2.5 Gb/s Data Transfer Rate (per pair data bandwidth)
- Accommodates 1.57mm ± 0.20mm [.062" ± .008"] PC board
- Nylon insulator
- 1.1 amp current rating per contact

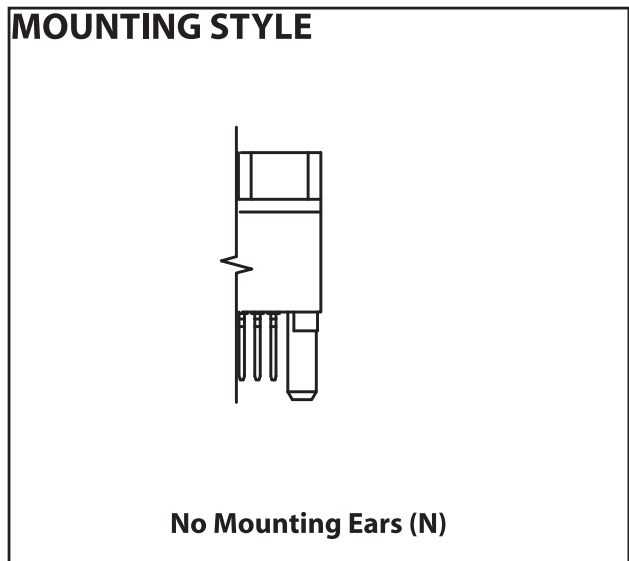
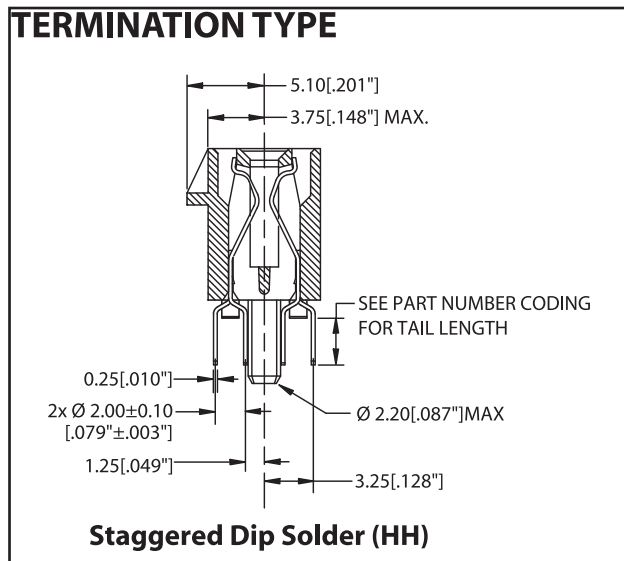
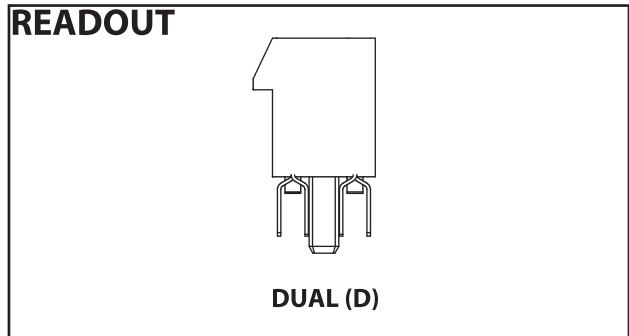



# High Density Card Edge

1.00 mm [.039"] Contact Centers, PCI Express, Card Extender for Straddle Mount

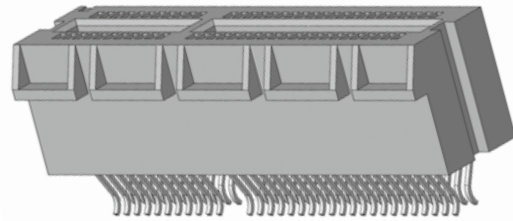

Sullins High Density

## DIMENSIONS

Dimensions in [ ] are in Inches, all others are in Millimeters

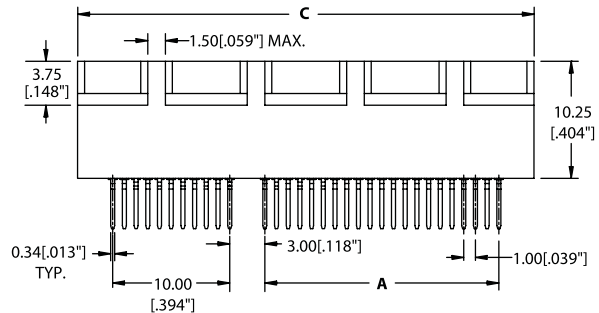
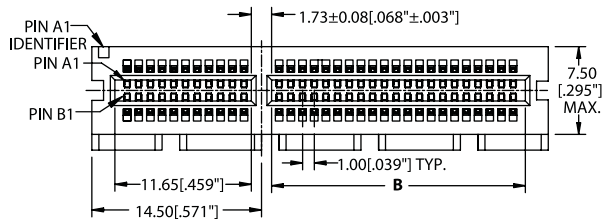

### STRADDLE MOUNT

Example Part Number: NBE18DHRN-T941

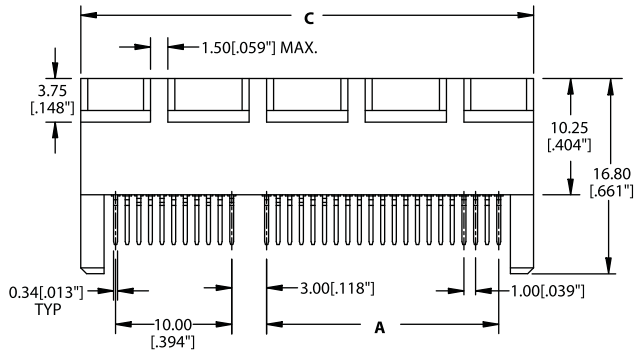
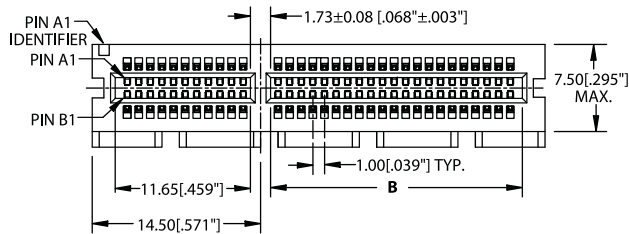

### STRADDLE MOUNT with PEGS

Example Part Number: NBE18DHRN-T9410

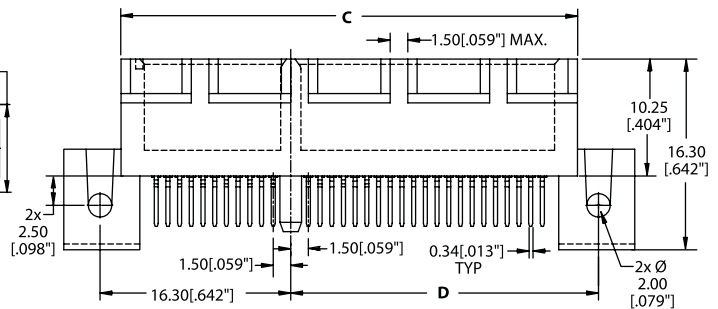
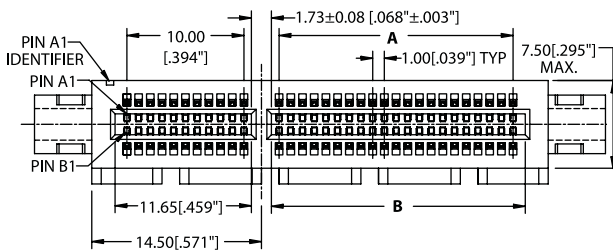

### STRADDLE MOUNT with CLIPS

Example Part Number: NBE18DHRQ-T941

POSITIONS/ CONTACTS	MILLIMETERS				[INCHES]			
	A ± 0.15	B ± 0.15	C ± 0.15	D ± 0.15	A ± 0.006"	B ± 0.006"	C ± 0.006"	D ± 0.006"
18/36	6.00	7.65	25.00	12.30	0.236	0.301	0.984	0.484
32/64	20.00	21.65	39.00	26.30	0.787	0.852	1.535	1.035
49/98	37.00	38.65	56.00	43.30	1.457	1.522	2.205	1.705
82/164	70.00	71.65	89.00	76.30	2.756	2.821	3.504	3.004



**1.00 mm [.039"] Contact Centers, PCI Express, Card Extender for Straddle Mount**

**PART NUMBER OPTIONS**

**MATERIALS (INSULATOR/CONTACT)** ——— **N B E 18 D HR N -T9 4 1 0**

N = Nylon/Phosphor Bronze((for hand soldering only)  
G = Nylon 9T/Phosphor Bronze

**CONTACT FINISH - RoHS Compliant** ———

**All platings are Lead Free and have .000050" Nickel underplate**

Material	Contact Surface	Termination
B = .000010" Gold	.000010" Gold	.000100" Pure Tin, Matte
C = .000030" Gold	.000030" Gold	.000100" Pure Tin, Matte
W = Gold Flash	Gold Flash	.000100" Pure Tin, Matte

**CONTACT CENTERS**  
E = 1mm [.039"]

**NUMBER OF CONTACT POSITIONS** ———  
18, 32, 49, 82

**READOUT** ———  
D = Dual

**MODIFICATION CODE**  
OMIT FOR STANDARD  
0 = Pegs  
(Available in 'N' Mounting Only)

**COLOR**  
1 = Black  
Other Options Available

**TAIL LENGTH**  
4 = 4.10mm [.161"]

**MOUNTING STYLE**  
N = No Mounting  
Q = Straddle Mount with Clips  
(\*Q' Not Available with T9410 Modification)

**TERMINATION TYPE**  
HR = Card Extender for Straddle Mount

Sullins High Density

**Operating & Processing Temperature: Consult Factory**

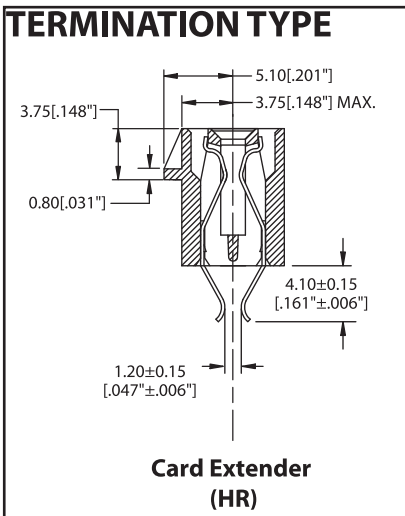

**SPECIFICATIONS**

- All PCI Express parts meet the latest PCI Express specifications
- Supports 2.5 Gb/s Data Transfer Rate (per pair data bandwidth)
- Accommodates 1.57mm ± 0 .20mm [.062" ± .008"] PC board
- Nylon insulator
- 1.1 amp current rating per contact
- UL Flammability Rating: 94V-0

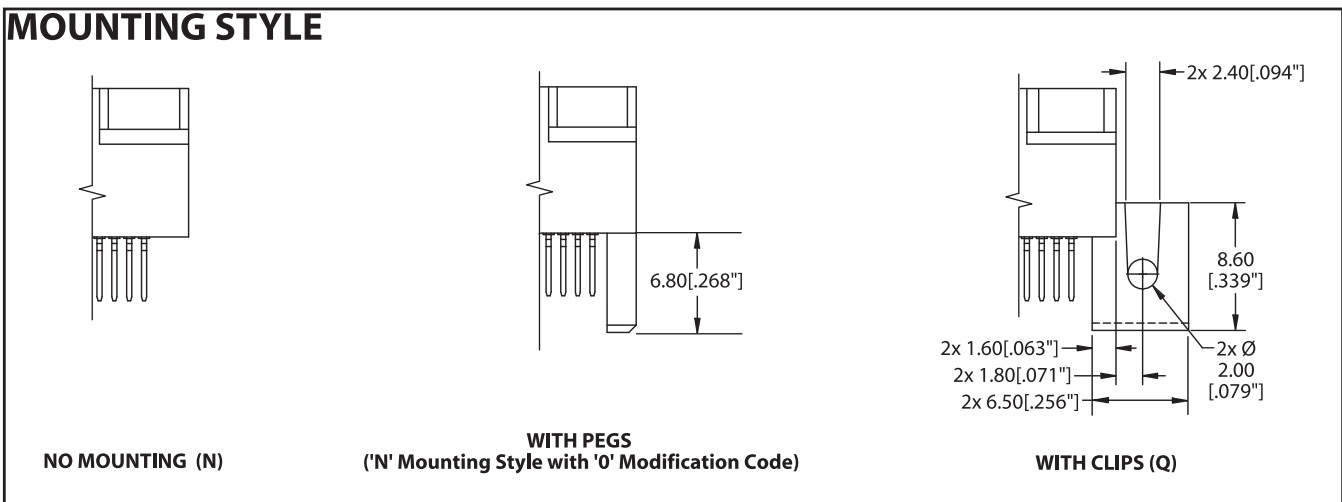
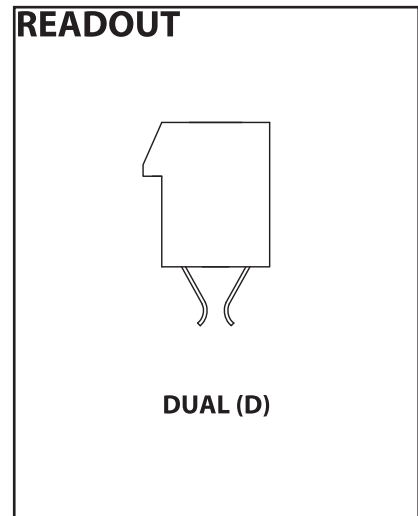



**1.00 mm [.039"] Contact Centers, PCI Express  
Right Angle**

**SPECIFICATIONS**

- All PCI Express parts meet the latest PCI Express specifications
- Supports 2.5 Gb/s Data Transfer Rate(per pair data bandwidth)
- Accommodates 1.57mm ± 0.20mm [.062" ± .008"] PC Board
- Nylon insulator
- 1.1 amp current rating per contact
- UL Flammability Rating: 94V-0

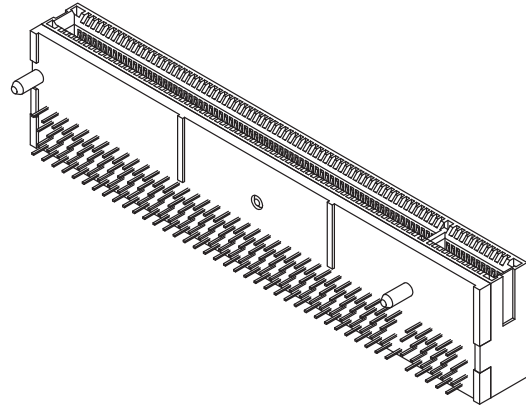

Sullins High Density

**DIMENSIONS**

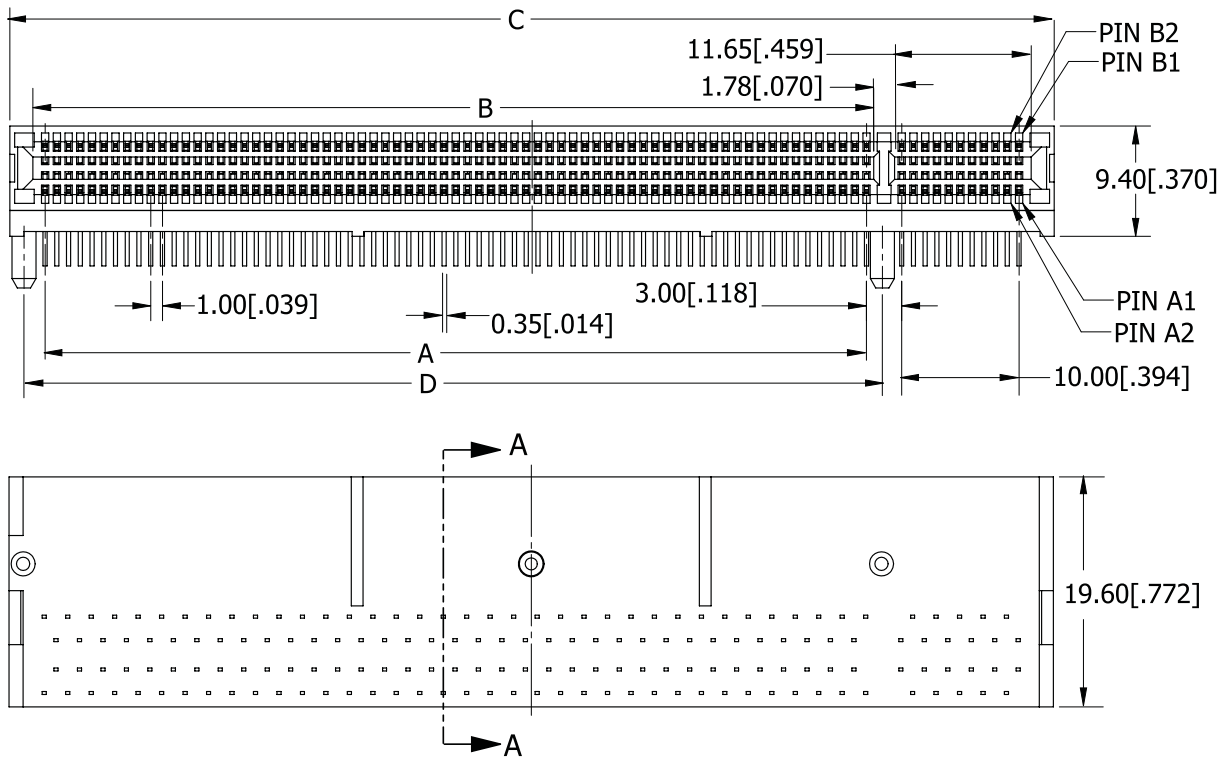

POSITIONS/ CONTACTS	MILLIMETERS				[INCHES]			
	A ± 0.25	B ± 0.25	C ± 0.25	D ± 0.25	A ± 0.010"	B ± 0.010"	C ± 0.010"	D ± 0.010"
18/36	6.00	7.65	25.00	9.15	0.236	0.301	0.984	0.360
32/64	20.00	21.65	39.00	23.15	0.787	0.852	1.535	0.911
49/98	37.00	38.65	56.00	40.15	1.457	1.522	2.205	1.581
82/164	70.00	71.65	89.00	73.15	2.756	2.821	3.504	2.880



**PART NUMBER OPTIONS**

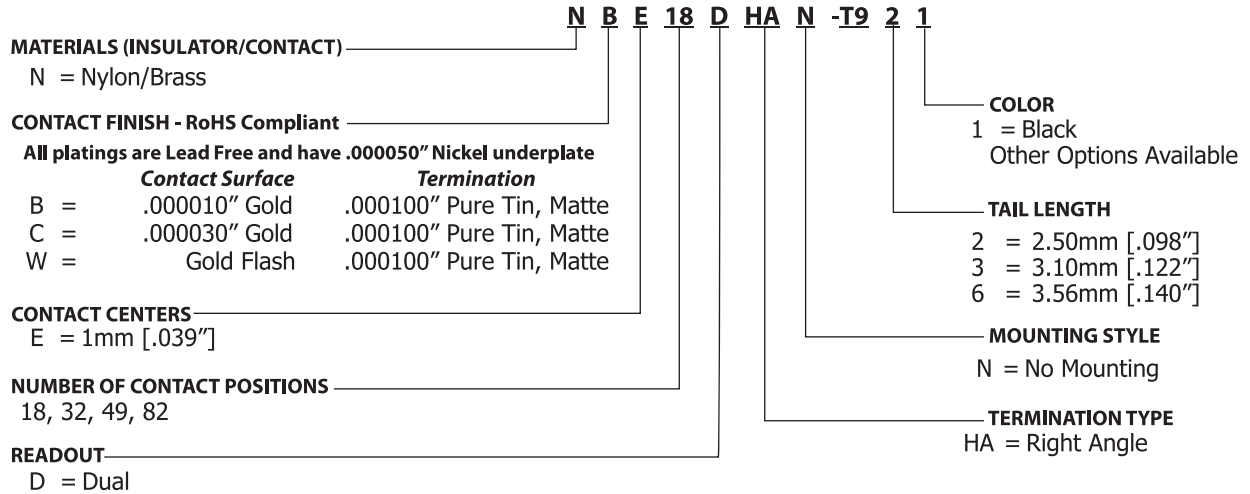

Sullins High Density

Operating & Processing Temperature: Consult Factory

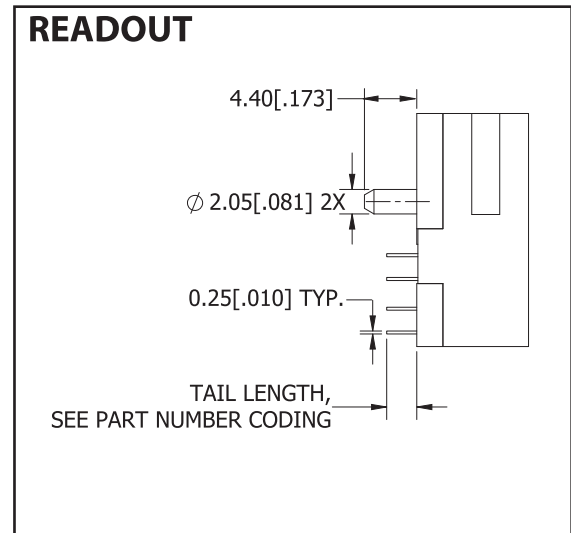
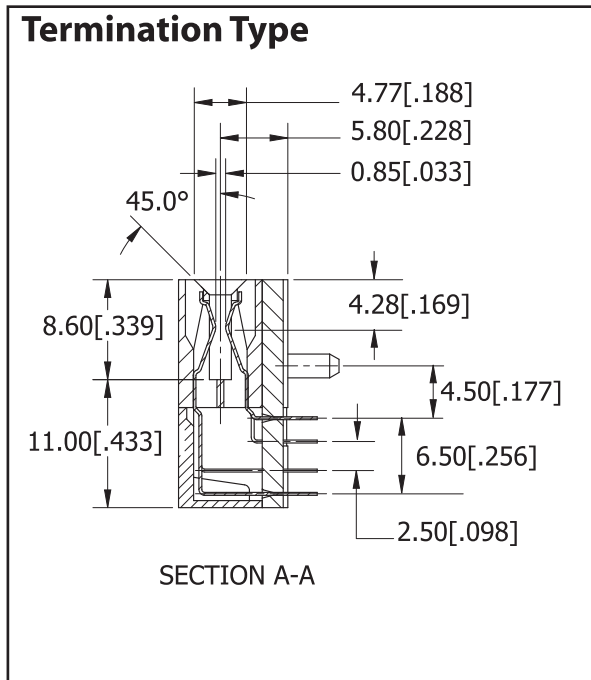





**PART NUMBER OPTIONS**

**G B E 18 D HF N -T951**

**MATERIALS (INSULATOR/CONTACT)**  
G = PA9T/ Phosphor Bronze

**CONTACT FINISH - RoHS Compliant**

All platings are Lead Free and have .000050" Nickel underplate

	Contact Surface	Termination
B =	.000010" Gold	.000100" Pure Tin, Matte
C =	.000030" Gold	.000100" Pure Tin, Matte
W =	Gold Flash	.000100" Pure Tin, Matte

**CONTACT CENTERS**  
E = 1mm [.039"]

**MOUNTING STYLE**  
N = No Mounting

**TERMINATION TYPE**  
HF = SURFACE MOUNT WITH POST

**READOUT**  
D = Dual

**NUMBER OF CONTACT POSITIONS**  
18, 32, 49, 82

Sullins High Density

Operating & Processing Temperature: Consult Factory

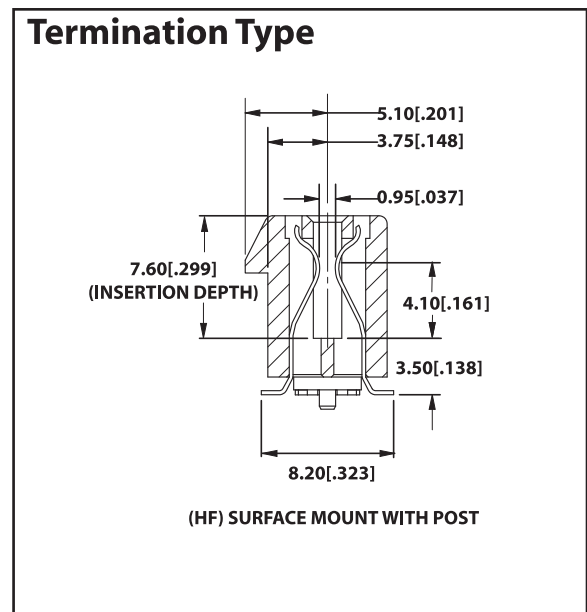
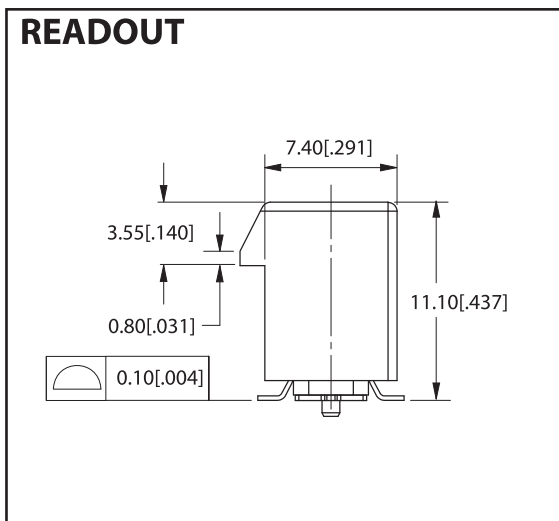

POSITIONS/ CONTACTS	MILLIMETERS					[INCHES]				
	A ± 0.10	B +0.15 /-0.05	C ± 0.23	D ± 0.20	E ± 0.20	A ± 0.004"	B +.006 /-.002"	C ± 0.009"	D ± 0.008"	E ± 0.008"
18/36	6.00	7.65	25.00	9.15	27.00	0.236	0.301	0.984	0.360	1.063
32/64	20.00	21.65	39.00	23.15	41.00	0.787	0.852	1.535	0.911	1.614
49/98	37.00	38.65	56.00	40.15	58.00	1.457	1.522	2.205	1.581	2.283
82/164	70.00	71.65	89.00	73.15	91.00	2.756	2.821	3.504	2.880	3.583



**1.00 mm [.039"] Contact Centers, PCI Express  
Dip Solder With Locking Mechanism**

**SPECIFICATIONS**

- All PCI Express parts meet the latest PCI Express specifications
- Supports 2.5 Gb/s Data Transfer Rate(per pair data bandwidth)
- Accommodates 1.57mm ± 0.20mm [.062" ± .008"] PC Board
- Nylon insulator
- 1 to 1.1 amp current rating per contact
- UL Flammability Rating: 94V-0

Sullins High Density

**DIMENSIONS**

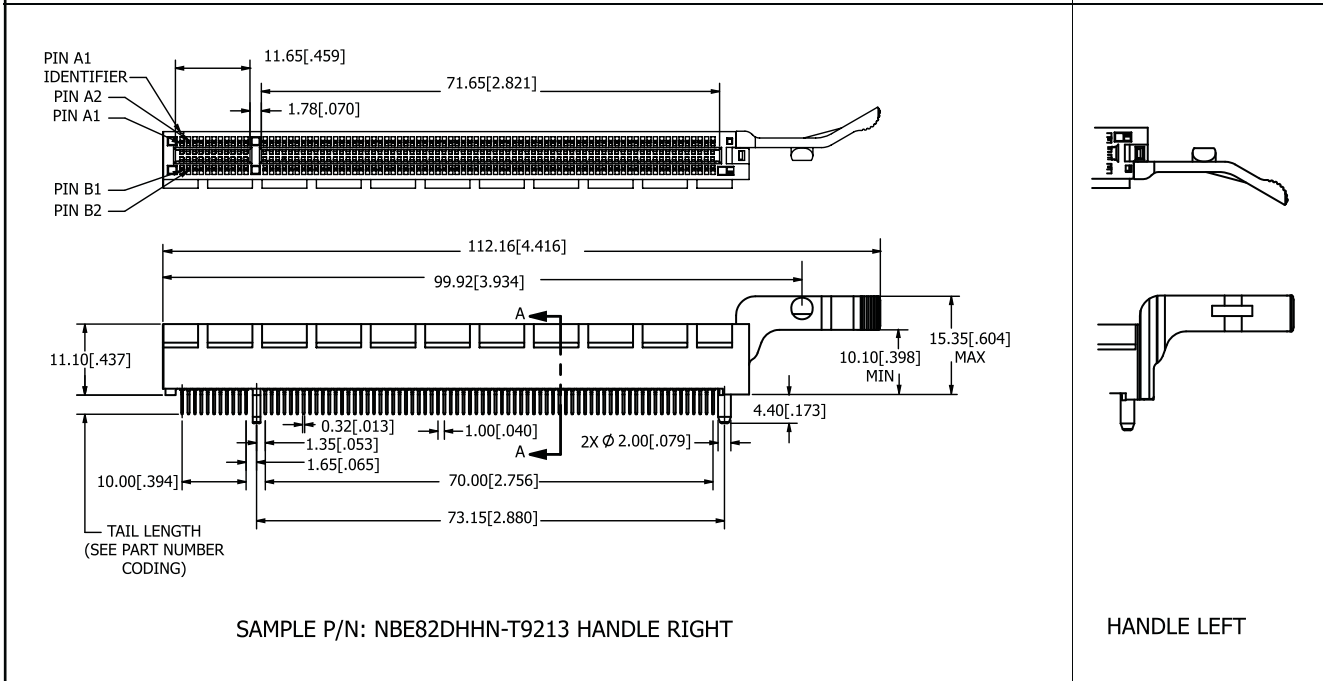
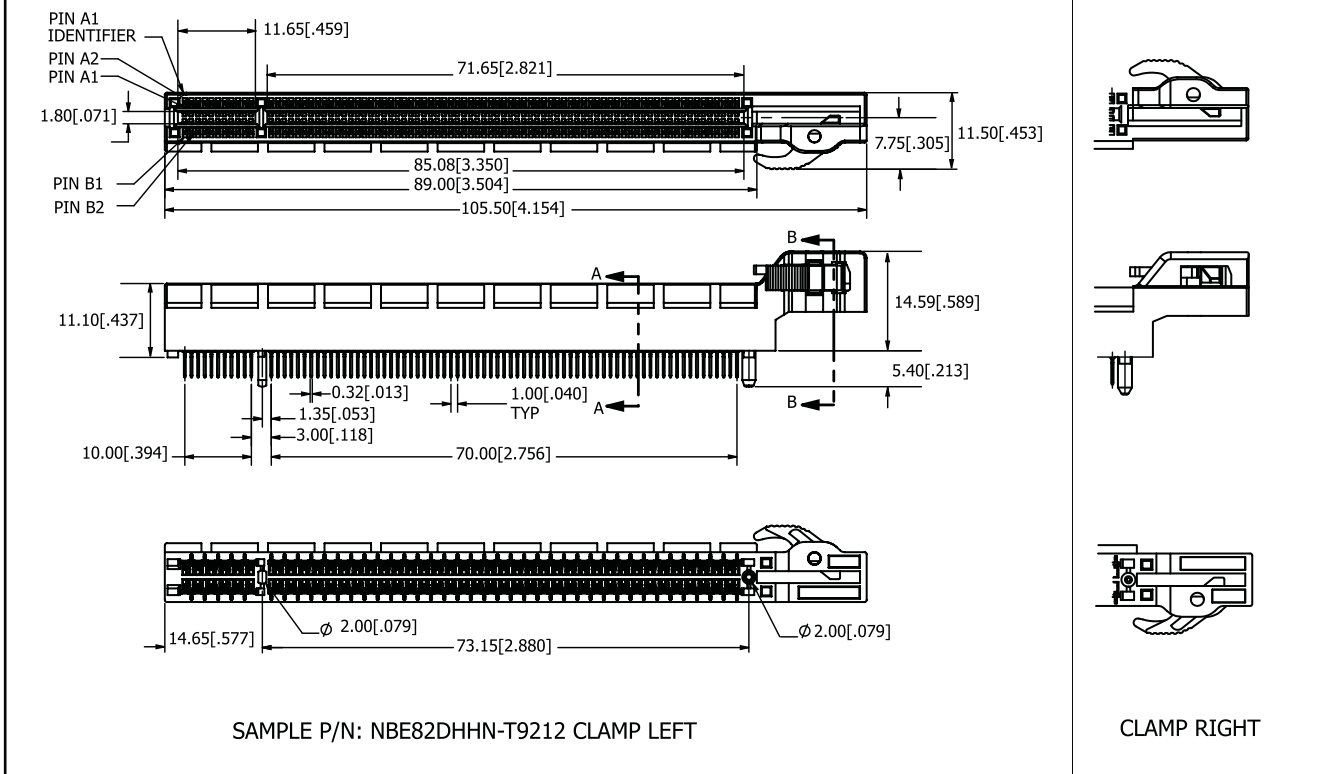



**PART NUMBER OPTIONS**

**MATERIALS (INSULATOR/CONTACT)** ——— **N B E 82 D HH N -T9 2 1 1**

N = Nylon/Brass

**CONTACT FINISH - RoHS Compliant**

All platings are Lead Free and have .000050" Nickel underplate

	Contact Surface	Termination
B =	.000010" Gold	.000100" Pure Tin, Matte
C =	.000030" Gold	.000100" Pure Tin, Matte
W =	Gold Flash	.000100" Pure Tin, Matte

**CONTACT CENTERS**

E = 1mm [.039"]

**NUMBER OF CONTACT POSITIONS** ———

**READOUT** ———

D = Dual

**LOCKING MECHANISM**

1 = Clamp Right  
2 = Clamp Left  
3 = Handle Right  
4 = Handle Left

**COLOR**

1 = Black  
5 = Light Blue

**TAIL LENGTH**

2 = 2.50mm [.098"]  
3 = 3.00mm [.118"]

**MOUNTING STYLE**

N = No Mounting

**TERMINATION TYPE**

HH = Staggered Dip Solder

**Operating & Processing Temperature: Consult Factory**

Sullins High Density

**Termination Type**

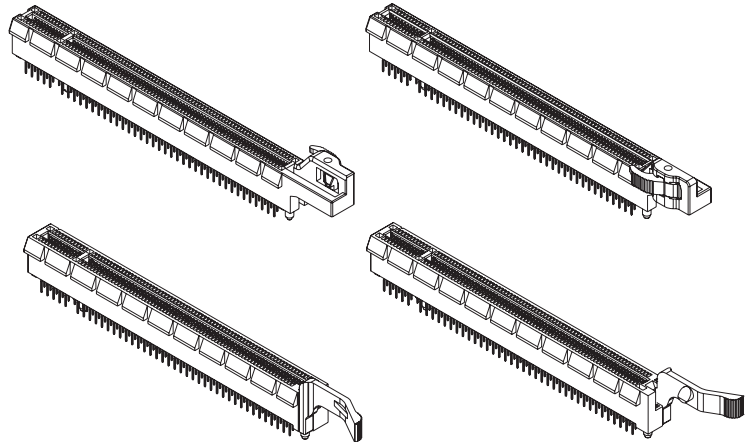
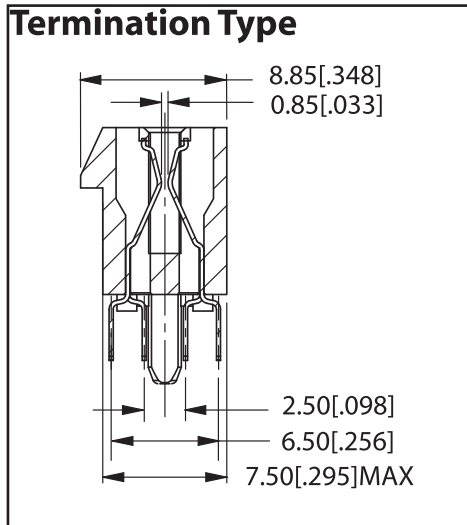

**Locking Mechanism**

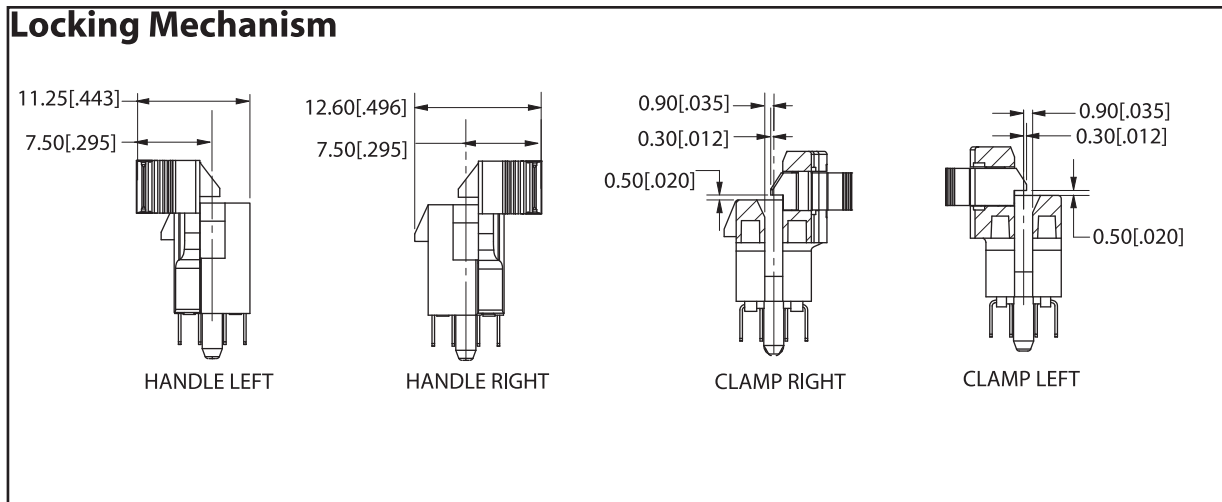



**.050" [1.27 mm] Contact Centers, .610" [15.49 mm] Insulator Height**  
**Dip Solder/Card Extender/SMT for .062" [1.57] or .031" [0.79] Mating PCB**

**SPECIFICATIONS**

- Accommodates .062" ± .008" [1.57 ± .20] PC board
- PPS or PA9T insulator
- Molded-in key available
- High reliability/high cycle hairpin bellows contact
- 1 amp current rating per contact
- UL Flammability Rating: 94V-0

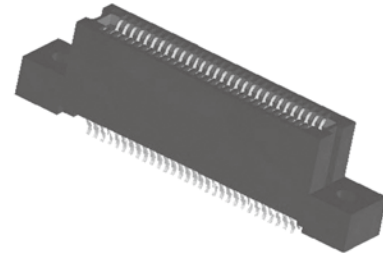

Sullins High Density

**TERMINATION TYPE**

HAIR PIN POST Ø .018 [0.46] X .012 [0.30]	(P/N CODE) TERMINATION LAYOUT	ROW SPACING ('R' DIM)	TAIL LENGTH ( 'L' DIM)
	(HH) THRU HOLE STRAIGHT figure 1	3X 0.100 [2.54]	0.125 [3.18]
	(HR) CARD EXTENDER figure 2	ACCEPTS .062 [1.57] PCB	0.160 [4.06]
	(HF) SURFACE MOUNT figure 3	N/A	0.100 [2.54]
	(HL) THRU HOLE STRAIGHT figure 4	0.250 [6.35]	0.160 [4.06]
	(HN) THRU HOLE STRAIGHT figure 4	.100 [2.54]	0.125 [3.18]
<b>CANTILEVER POST SIZE .016 [0.42] SQ</b>			
	(YH) THRU HOLE STRAIGHT figure 1	3X .100 [2.54]	0.125 [3.18]
	(YR) CARD EXTENDER figure 2	ACCEPTS .062 [1.57] PCB	0.175 [4.45]
	(YF) SURFACE MOUNT figure 3	N/A	0.100 [2.54]

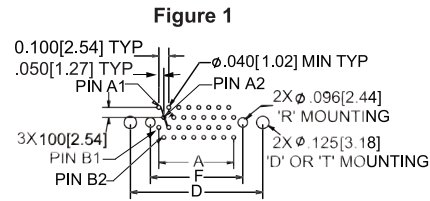

PCB LAYOUT RECOMMENDED (HH, YH)

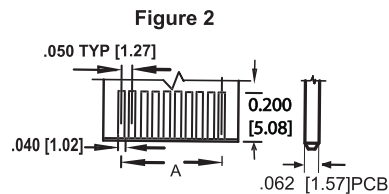

PCB LAYOUT, SOLDER END (HR, YR)

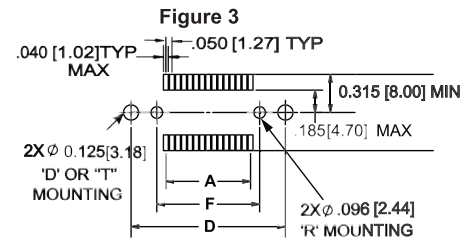

SURFACE MOUNT PCB LAYOUT, (HF, YF)

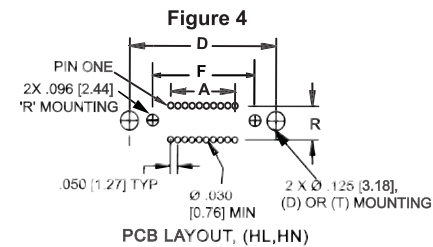

PCB LAYOUT, (HL, HN)

**MOUNTING STYLE**

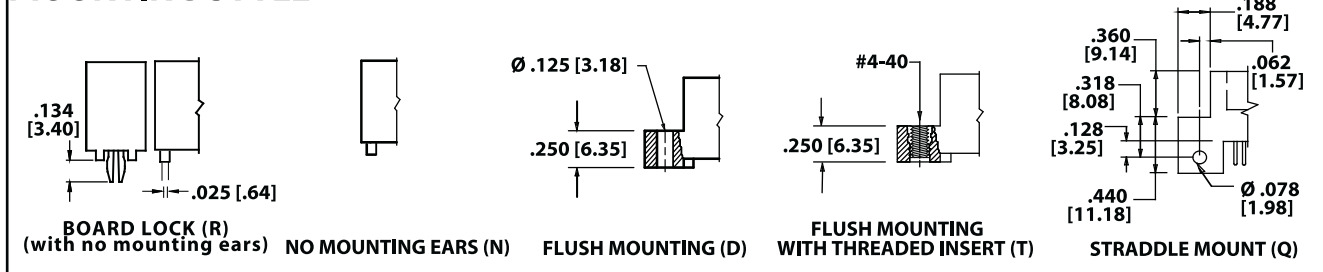



**.050" [1.27 mm] Contact Centers, .610" [15.49 mm] Insulator Height**  
**Dip Solder/Card Extender/SMT for .062" [1.57] or .031" [0.79] Mating PCB**

**PART NUMBER OPTIONS**

**G B B 40 D HH D - Sxxx**

**MODIFICATION CODE (Consult Factory)**  
OMIT FOR STANDARD  
-S1648 = .031+-0.006[0.79+-0.15] Mating PCB (for HH, HR, HF, HN & HL Termination Only)

**MATERIALS (INSULATOR/CONTACT)**  
G = PA9T/Phosphor Bronze  
R = PPS/Phosphor Bronze  
J = PA9T/Beryllium Copper  
A = PPS/Beryllium Copper

**CONTACT FINISH - RoHS Compliant**

**CONTACT CENTERS**  
B = .050 [1.27mm]

**NUMBER OF CONTACT POSITIONS**  
See Chart Below

**READOUT (Opposite Page)**  
D = Dual

**MOUNTING STYLE (Opposite Page)**  
D = Flush Mounting  
N = No Mounting  
T = Flush Mounting With Threaded Insert  
Q = Straddle Mount (Card Extender Only)  
R = Metal Board locks

**TERMINATION TYPE (Opposite Page)**  
HH, YH = Staggered Dip Solder  
HR, YR = Card Extender  
HF, YF = Surface Mount  
HL = Dip Solder  
HN = Dip Solder  
(Replaces Terminations CH, CR, CF, CL, CN)

**All platings are Lead Free and have .000050" Nickel underplate**  
**Contact Surface Termination**  
B = .000010" Gold .000100" Pure Tin, Matte  
C = .000030" Gold .000100" Pure Tin, Matte

Sullins High Density

**DIMENSIONS** Dimensions in [ ] are in millimeters, all others are in inches.

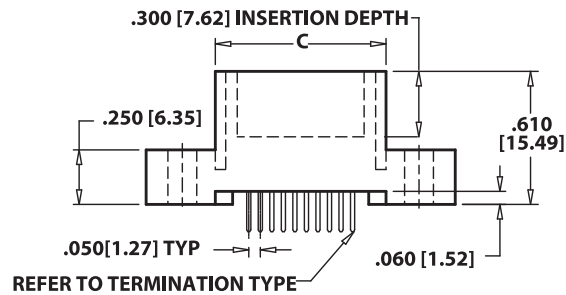
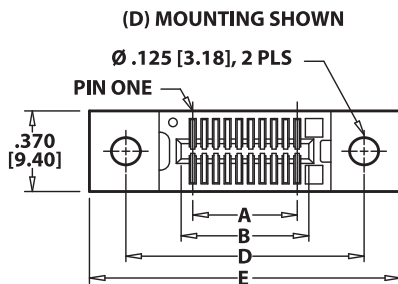

POSITIONS/ CONTACTS	INCHES						[MILLIMETERS]					
	A ±.005	B ±.005	C ±.015	D ±.010	E ±.020	F ±.010	A ±.13	B ±.13	C ±.38	D ±.25	E ±.51	F ±.25
05/10	0.200	0.300	0.490	0.776	1.090	0.350	5.08	7.62	12.45	19.71	27.69	8.89
06/12	0.250	0.350	0.540	0.826	1.140	0.400	6.35	8.89	13.72	20.98	28.96	10.16
09/18	0.400	0.500	0.690	0.976	1.290	0.550	10.16	12.70	17.53	24.79	32.77	13.97
10/20	0.450	0.550	0.740	1.026	1.340	0.600	11.43	13.97	18.80	26.06	34.04	15.24
13/26	0.600	0.700	0.890	1.176	1.490	0.750	15.24	17.78	22.61	29.87	37.85	19.05
14/28*	0.650	0.750	0.940	1.226	1.540	0.800	16.51	19.05	23.88	31.14	39.12	20.32
15/30	0.700	0.800	0.990	1.276	1.590	0.850	17.78	20.32	25.15	32.41	40.39	21.59
20/40	0.950	1.050	1.240	1.526	1.840	1.100	24.13	26.67	31.50	38.76	46.74	27.94
22/44	1.050	1.150	1.340	1.626	1.940	1.200	26.67	29.21	34.04	41.30	49.28	30.48
24/48*	1.150	1.250	1.440	1.726	2.040	1.300	29.21	31.75	36.58	43.84	51.82	33.02
25/50	1.200	1.300	1.490	1.776	2.090	1.350	30.48	33.02	37.85	45.11	53.09	34.29
30/60	1.450	1.550	1.740	2.026	2.340	1.600	36.83	39.37	44.20	51.46	59.44	40.64
34/68	1.650	1.750	1.940	2.226	2.540	1.800	41.91	44.45	49.28	56.54	64.52	45.72
35/70	1.700	1.800	1.990	2.276	2.590	1.850	43.18	45.72	50.55	57.81	65.79	46.99
40/80	1.950	2.050	2.240	2.526	2.840	2.100	49.53	52.07	56.90	64.16	72.14	53.34
45/90	2.200	2.300	2.490	2.776	3.090	2.350	55.88	58.42	63.25	70.51	78.49	59.69
50/100	2.450	2.550	2.740	3.026	3.340	2.600	62.23	64.77	69.60	76.86	84.84	66.04
55/110*	2.700	2.800	2.990	3.276	3.590	2.850	68.58	71.12	75.95	83.21	91.19	72.39
60/120	2.950	3.050	3.240	3.526	3.840	3.100	74.93	77.47	82.30	89.56	97.54	78.74
64/128	3.150	3.250	3.440	3.726	4.040	3.300	80.01	82.55	87.38	94.64	102.62	83.82
65/130*	3.200	3.300	3.490	3.776	4.090	3.350	81.28	83.82	88.65	95.91	103.89	85.09
66/132*	3.250	3.350	3.540	3.826	4.140	3.400	82.55	85.09	89.92	97.18	105.16	86.36
70/140*	3.450	3.550	3.740	4.026	4.340	3.600	87.63	90.17	95.00	102.26	110.24	91.44
75/150	3.700	3.800	3.990	4.276	4.590	3.850	93.98	96.52	101.35	108.61	116.59	97.79
80/160	3.950	4.050	4.240	4.526	4.840	4.100	100.33	102.87	107.70	114.96	122.94	104.14
85/170*	4.200	4.300	4.490	4.776	5.090	4.350	106.68	109.22	114.05	121.31	129.29	110.49
90/180	4.450	4.550	4.740	5.026	5.340	4.600	113.03	115.57	120.40	127.66	135.64	116.84
95/190*	4.700	4.800	4.990	5.276	5.590	4.850	119.38	121.92	126.75	134.01	141.99	123.19
100/200	4.950	5.050	5.240	5.526	5.840	5.100	125.73	128.27	133.10	140.36	148.34	129.54
105/210	5.200	5.300	5.490	5.776	6.090	5.350	132.08	134.62	139.45	146.71	154.69	135.89
108/216*	5.350	5.450	5.640	5.926	6.240	5.500	135.89	138.43	143.26	150.52	158.50	139.70
110/220	5.450	5.550	5.740	6.026	6.340	5.600	138.43	140.97	145.80	153.06	161.04	142.24
120/240	5.950	6.050	6.240	'N' Mounting Only	6.100	6.100	151.13	153.67	158.50	'N' Mounting Only	154.94	

\* Consult Factory For Availability.



**.050" [1.27 mm] Contact Centers, .915" [23.23 mm] Insulator Height  
Right Angle**

**SPECIFICATIONS**

- Accommodates .062" ± .008" [1.57 ± .20] PC board
- PPS or PA9T insulator
- Molded-in key available
- High reliability/high cycle hairpin bellows contact
- 1 amp current rating per contact
- UL Flammability Rating: 94V-0

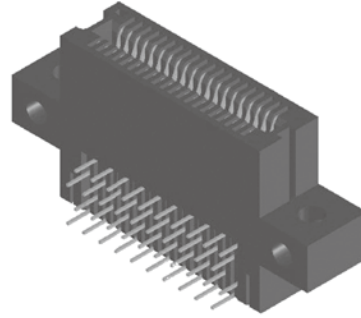

**READOUT & TERMINATION TYPE**

**HAIRPIN**

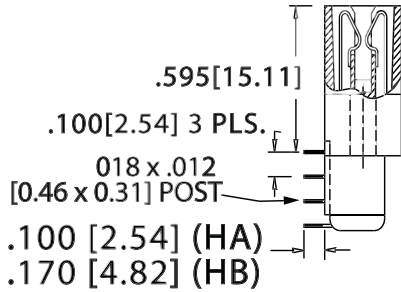

**CANTILEVER**

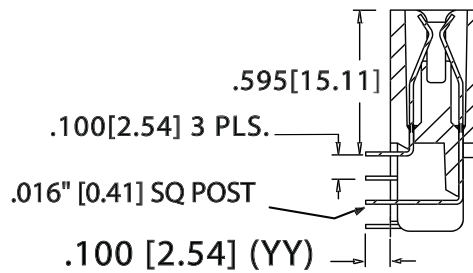

**DUAL READOUT (D)**

**PCB LAYOUT**

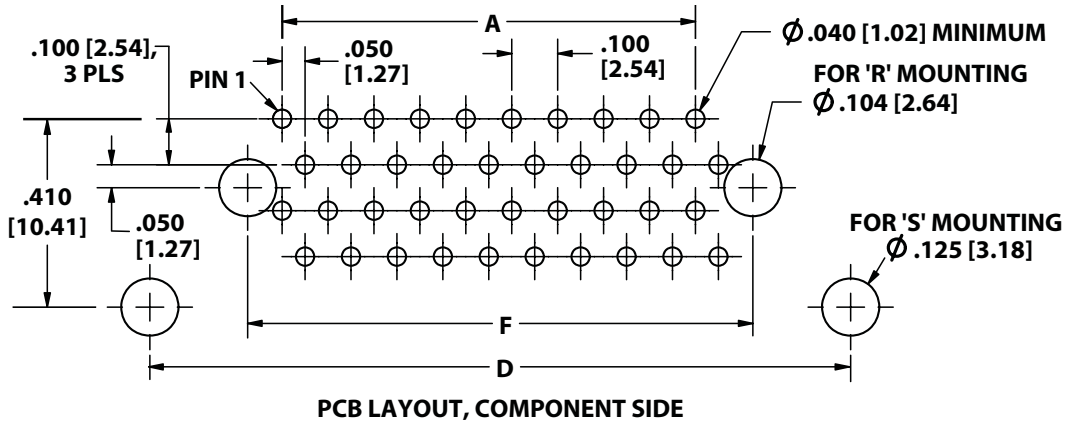

**MOUNTING STYLE**

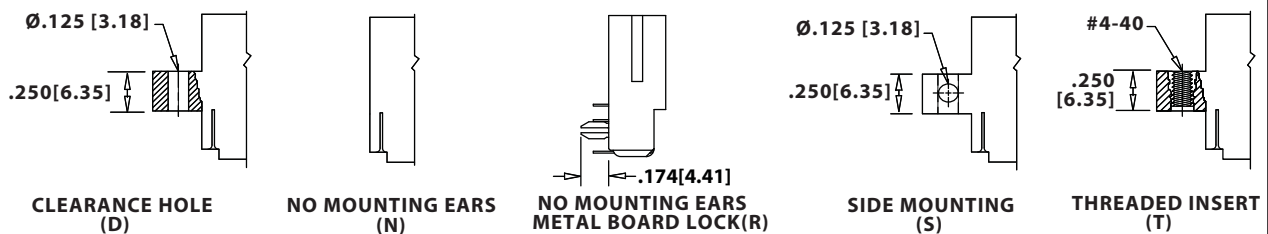



**.050" [1.27 mm] Contact Centers, .610" [15.49 mm] Insulator height**

**Right Angle**

**PART NUMBER OPTIONS**

**G B B 10 D HA S - Sxxx**

**MATERIALS (INSULATOR/CONTACT)**  
 G = PA9T/Phosphor Bronze  
 R = PPS/Phosphor Bronze  
 J = PA9T/Beryllium Copper  
 A = PPS/Beryllium Copper

**CONTACT FINISH - RoHS Compliant**  
**All platings are Lead Free and have .000050" Nickel underplate**  
**Contact Surface Termination**  
 B = .000010" Gold .000100" Pure Tin, Matte  
 C = .000030" Gold .000100" Pure Tin, Matte

**CONTACT CENTERS**  
 B = .050" [1.27mm]

**MODIFICATION CODE (Consult Factory)**  
 OMIT FOR STANDARD

**MOUNTING STYLE (Opposite Page)**  
 S = Side Mounting  
 D = Flush Mounting  
 N = No Mounting  
 T = Flush Mounting With Threaded Insert  
 R = Metal Board Lock

**TERMINATION TYPE (Opposite Page)**  
 HA, YY = .100" Staggered Right Angle  
 HB = .170" Staggered Right Angle

**READOUT (Opposite Page)**  
 D = Dual

**NUMBER OF CONTACT POSITIONS**  
 See Chart Below

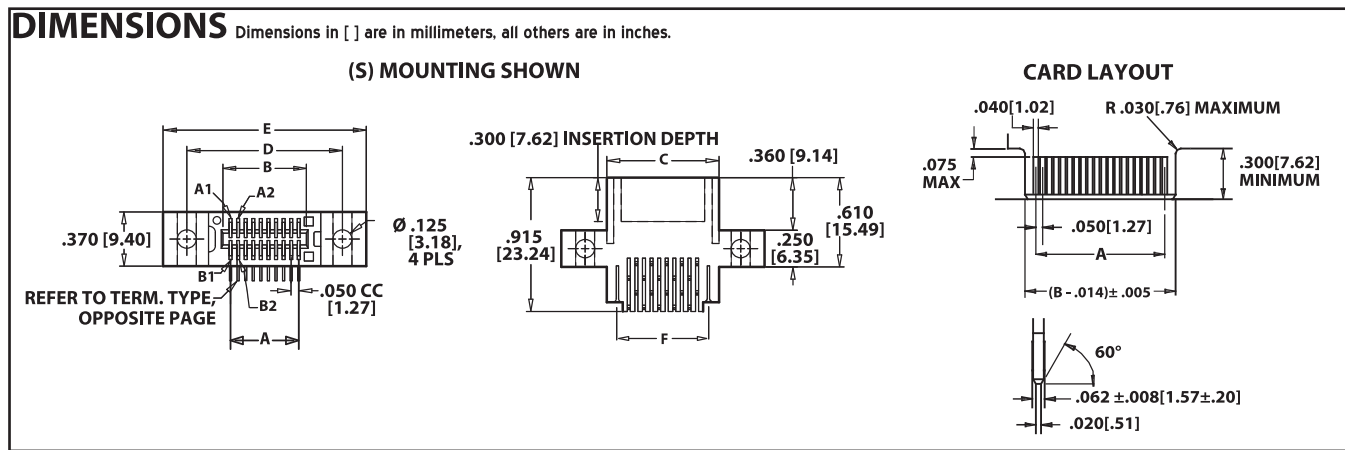

POSITIONS/ CONTACTS*	INCHES						[MILLIMETERS]					
	A ±.005	B ±.005	C ±.015	D ±.010	E ±.020	F ±.010	A ±.13	B ±.13	C ±.38	D ±.25	E ±.51	F ±.25
05/10	0.200	0.300	0.490	0.776	1.090	0.350	5.08	7.62	12.45	19.71	27.69	8.89
06/12	0.250	0.350	0.540	0.826	1.140	0.400	6.35	8.89	13.72	20.98	28.96	10.16
09/18	0.400	0.500	0.690	0.976	1.290	0.550	10.16	12.70	17.53	24.79	32.77	13.97
10/20	0.450	0.550	0.740	1.026	1.340	0.600	11.43	13.97	18.80	26.06	34.04	15.24
13/26	0.600	0.700	0.890	1.176	1.490	0.750	15.24	17.78	22.61	29.87	37.85	19.05
14/28	0.650	0.750	0.940	1.226	1.540	0.800	16.51	19.05	23.88	31.14	39.12	20.32
15/30	0.700	0.800	0.990	1.276	1.590	0.850	17.78	20.32	25.15	32.41	40.39	21.59
20/40	0.950	1.050	1.240	1.526	1.840	1.100	24.13	26.67	31.50	38.76	46.74	27.94
22/44	1.050	1.150	1.340	1.626	1.940	1.200	26.67	29.21	34.04	41.30	49.28	30.48
* 24/48	1.150	1.250	1.440	1.726	2.040	1.300	29.21	31.75	36.58	43.84	51.82	33.02
25/50	1.200	1.300	1.490	1.776	2.090	1.350	30.48	33.02	37.85	45.11	53.09	34.29
30/60	1.450	1.550	1.740	2.026	2.340	1.600	36.83	39.37	44.20	51.46	59.44	40.64
34/68	1.650	1.750	1.940	2.226	2.540	1.800	41.91	44.45	49.28	56.54	64.52	45.72
35/70	1.700	1.800	1.990	2.276	2.590	1.850	43.18	45.72	50.55	57.81	65.79	46.99
40/80	1.950	2.050	2.240	2.526	2.840	2.100	49.53	52.07	56.90	64.16	72.14	53.34
45/90	2.200	2.300	2.490	2.776	3.090	2.350	55.88	58.42	63.25	70.51	78.49	59.69
50/100	2.450	2.550	2.740	3.026	3.340	2.600	62.23	64.77	69.60	76.86	84.84	66.04
55/110	2.700	2.800	2.990	3.276	3.590	2.850	68.58	71.12	75.95	83.21	91.19	72.39
60/120	2.950	3.050	3.240	3.526	3.840	3.100	74.93	77.47	82.30	89.56	97.54	78.74
64/128	3.150	3.250	3.440	3.726	4.040	3.300	80.01	82.55	87.38	94.64	102.62	83.82
65/130	3.200	3.300	3.490	3.776	4.090	3.350	81.28	83.82	88.65	95.91	103.89	85.09
66/132	3.250	3.350	3.540	3.826	4.140	3.400	82.55	85.09	89.92	97.18	105.16	86.36
70/140	3.450	3.550	3.740	4.026	4.340	3.600	87.63	90.17	95.00	102.26	110.24	91.44
75/150	3.700	3.800	3.990	4.276	4.590	3.850	93.98	96.52	101.35	108.61	116.59	97.79
80/160	3.950	4.050	4.240	4.526	4.840	4.100	100.33	102.87	107.70	114.96	122.94	104.14
85/170	4.200	4.300	4.490	4.776	5.090	4.350	106.68	109.22	114.05	121.31	129.29	110.49
90/180	4.450	4.550	4.740	5.026	5.340	4.600	113.03	115.57	120.40	127.66	135.64	116.84
95/190	4.700	4.800	4.990	5.276	5.590	4.850	119.38	121.92	126.75	134.01	141.99	123.19
100/200	4.950	5.050	5.240	5.526	5.840	5.100	125.73	128.27	133.10	140.36	148.34	129.54
105/210	5.200	5.300	5.490	5.776	6.090	5.350	132.08	134.62	139.45	146.71	154.69	135.89
108/216	5.350	5.450	5.640	5.926	6.240	5.500	135.89	138.43	143.26	150.52	158.50	139.70
110/220	5.450	5.550	5.740	6.026	6.340	5.600	138.43	140.97	145.80	153.06	161.04	142.24
120/240	5.950	6.050	6.240	'N' Mounting Only	6.100	6.100	151.13	153.67	158.50	'N' Mounting Only	154.94	154.94

\* Consult Factory For Availability and for sizes not shown



### SPECIFICATIONS

- Accommodates .062" ± .008" [1.57 ± .20] PC board  
(Consult factory for other board thicknesses)
- PPS or PA9T insulator
- Molded-in key available
- High reliability/high cycle hairpin bellows contact
- 1 amp current rating per contact
- UL Flammability Rating: 94V-0

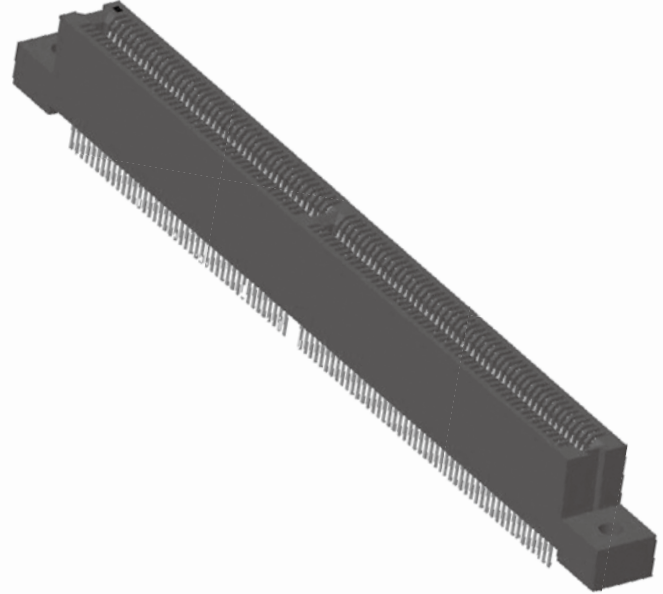

### READOUT

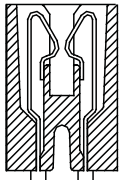

DUAL (D)

### TERMINATION TYPE

Consult Factory for PC Board Layouts

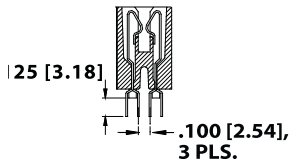

STAGGERED DIP SOLDER (HH)

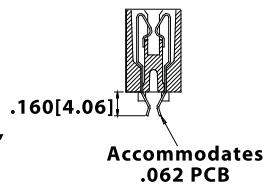

CARD EXTENDER (HR)

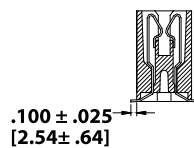

SURFACE MOUNT (HF)

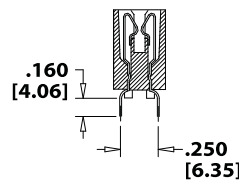

DIP SOLDER (HL)

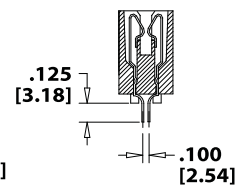

DIP SOLDER (HN)

### MOUNTING STYLE



NO MOUNTING EARS (N)

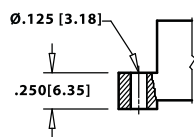

FLUSH MOUNTING (D)

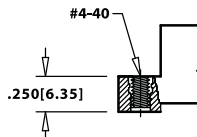

FLUSH MOUNTING WITH THREADED INSERT (T)

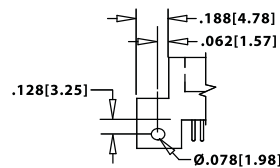

STRADDLE MOUNT (Q)

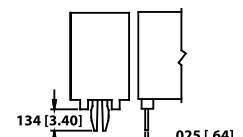

BOARD LOCK (R)  
(with no mounting ears)



**.050" [1.27 mm] Contact Centers, .610" [15.49 mm] Insulator Height [MCA] Dip Solder/Card Extender/SMT**

Industry Standard Part

**PART NUMBER OPTIONS**

**MATERIALS (Insulator/Contact)**  
 G = PA9T/Phosphor Bronze  
 R = PPS/Phosphor Bronze  
 J = PA9T/Beryllium Copper  
 A = PPS/Beryllium Copper

**CONTACT FINISH - RoHS Compliant**  
**All platings are Lead Free and have .000050" Nickel underplate**

<b>Contact Surface</b>	<b>Termination</b>
B = .000010" Gold	.000100" Pure Tin, Matte
C = .000030" Gold	.000100" Pure Tin, Matte

**CONTACT CENTERS**  
 B = .050" [1.27mm]

**NUMBER OF CONTACT POSITIONS**  
 56, 66, 91, 106

**MODIFICATION (Consult Factory)**  
 -S578 = Card Slot Barriers With Guide Posts  
 -S621 = Card Slot Barriers Without Guide Posts

**MOUNTING STYLE**  
 N = No Mounting  
 D = Flush Mounting  
 T = Flush Mounting With Threaded Insert  
 Q = Straddle Mount (Card Extender Only)  
 R = Metal Board Lock

**TERMINATION TYPE**  
 HH = Staggered Dip Solder  
 HR = Card Extender  
 HF = Surface Mount  
 HL = .250" [6.35mm] x .160" [4.06mm] Dip Solder  
 HN = .100" [2.54mm] x .125" [3.18mm] Dip Solder  
 (REPLACES TERMINATIONS: CH, CR, CF, CL, CN)

**READOUT**  
 D = Dual

Sullins High Density

**DIMENSIONS**

Dimensions in [ ] are in millimeters, all others are in inches.

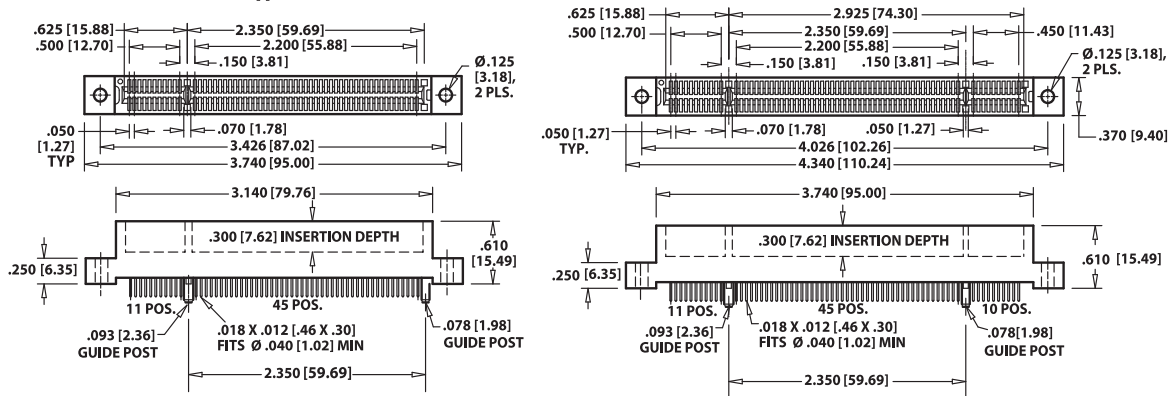

**GBB56DHHDD-S578, 56 (11/45) POSITIONS**

**GBB66DHHDD-S578, 66 (11/45/10) POSITIONS**

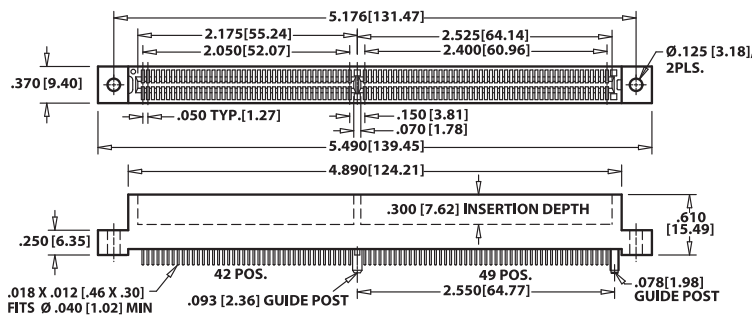

**GBB91DHHDD-S578, 91 (42/49) POSITIONS**

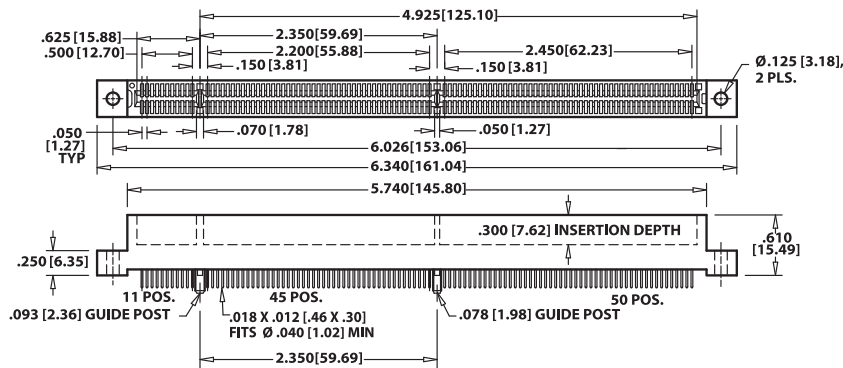

**GBB106DHHDD-S578, 106 (11/45/50) POSITIONS**



# High Density Card Edge

## .050" [1.27 mm] Contact Centers, .915" [23.23 mm] Insulator Height [MCA] Right Angle - Industry Standard Part

Sullins High Density

### DIMENSIONS

Dimensions in [ ] are in millimeters, all others are in inches.

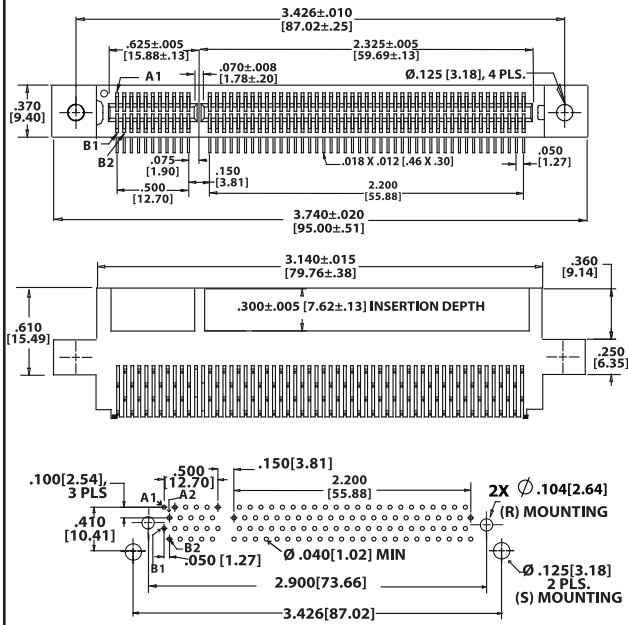

GBB56DHAS-S621, 56(11/45) POSITIONS

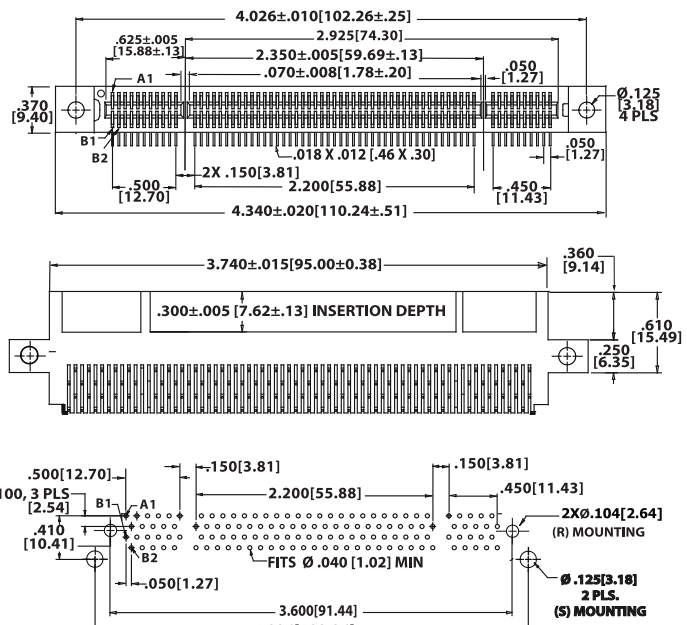

GBB66DHAS-S621, 66(11/45/10) POSITIONS

### MOUNTING STYLE

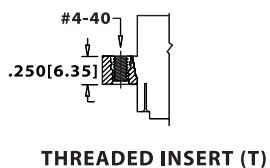
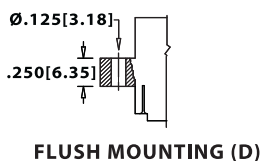
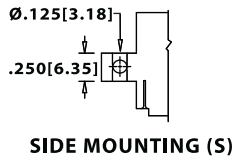
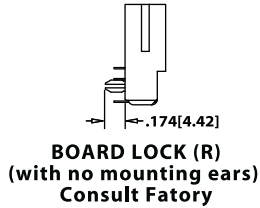

### DIMENSIONS

Dimensions in [ ] are in millimeters, all others are in inches.

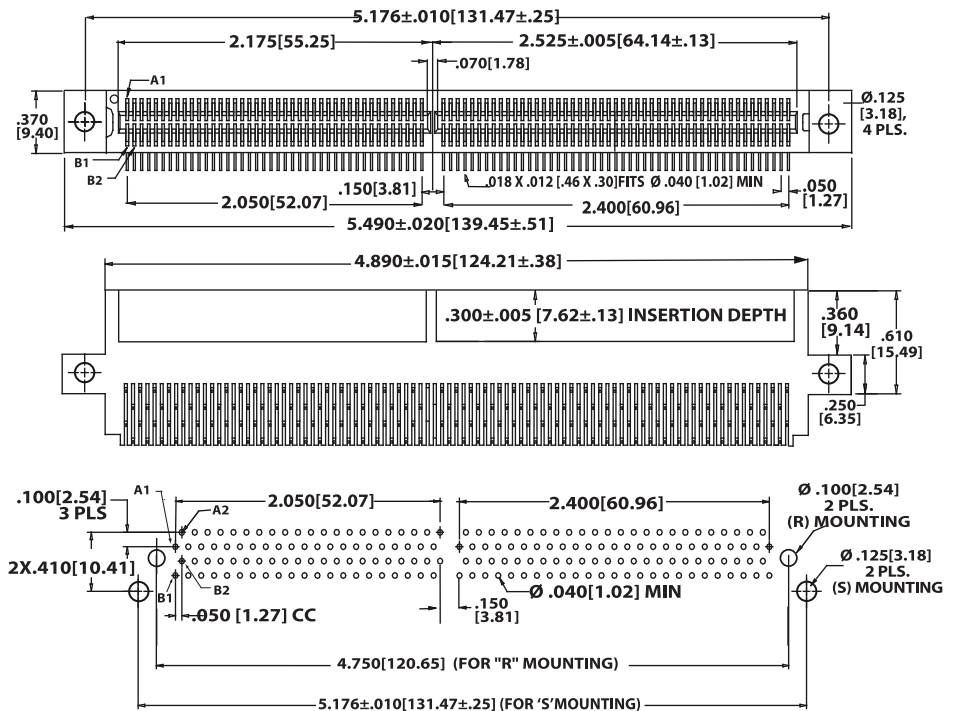

GBB91DHAS-S621, 91 (42/49) POSITIONS



**.050" [1.27 mm] Contact Centers, .915" [23.23 mm] Insulator Height [MCA] Right Angle**

Industry Standard Part

**PART NUMBER OPTIONS**

<p><b>MATERIALS (Insulator/Contact)</b></p> <p>G = PA9T/Phosphor Bronze R = PPS/Phosphor Bronze J = PA9T/Beryllium Copper A = PPS/Beryllium Copper</p> <p><b>CONTACT FINISH - RoHS Compliant</b></p> <p>All platings are Lead Free and have .000050" Nickel underplate</p> <table border="0"> <tr> <td><b>Contact Surface</b></td> <td><b>Termination</b></td> </tr> <tr> <td>B = .000010" Gold</td> <td>.000100" Pure Tin, Matte</td> </tr> <tr> <td>C = .000030" Gold</td> <td>.000100" Pure Tin, Matte</td> </tr> </table> <p><b>CONTACT CENTERS</b></p> <p>B = .050" [1.27mm]</p>	<b>Contact Surface</b>	<b>Termination</b>	B = .000010" Gold	.000100" Pure Tin, Matte	C = .000030" Gold	.000100" Pure Tin, Matte	<p><b>G B B 56 D HA D - S621</b></p> <p><b>MODIFICATION (CONSULT FACTORY)</b></p> <p>-S621 = Card Slot Barriers Without Guide Posts</p> <p><b>MOUNTING STYLE (Opposite Page)</b></p> <p>S = Side Mounting D = Flush Mounting N = No Mounting T = Flush Mounting With Threaded Insert R = Metal Board Lock</p> <p><b>TERMINATION TYPE</b></p> <p>HA = .100" [2.54] Staggered Right Angle HB = .170" [4.32] Staggered Right Angle</p> <p><b>READOUT</b></p> <p>D = Dual</p> <p><b>NUMBER OF CONTACT POSITIONS</b></p> <p>56 = 11/45 66 = 11/45/10 91 = 42/49 106 = 11/45/50</p>
<b>Contact Surface</b>	<b>Termination</b>						
B = .000010" Gold	.000100" Pure Tin, Matte						
C = .000030" Gold	.000100" Pure Tin, Matte						

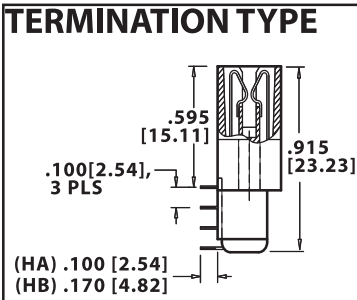

**SPECIFICATIONS**

- Accommodates .062" ± .008" [1.57 ± .20] PC board
- PPS or PA9T insulator
- Molded-in key available
- High reliability/high cycle hairpin bellows contact
- 1 amp current rating per contact
- UL Flammability Rating: 94V-0

**DIMENSIONS**

Dimensions in [ ] are in millimeters, all others are in inches.

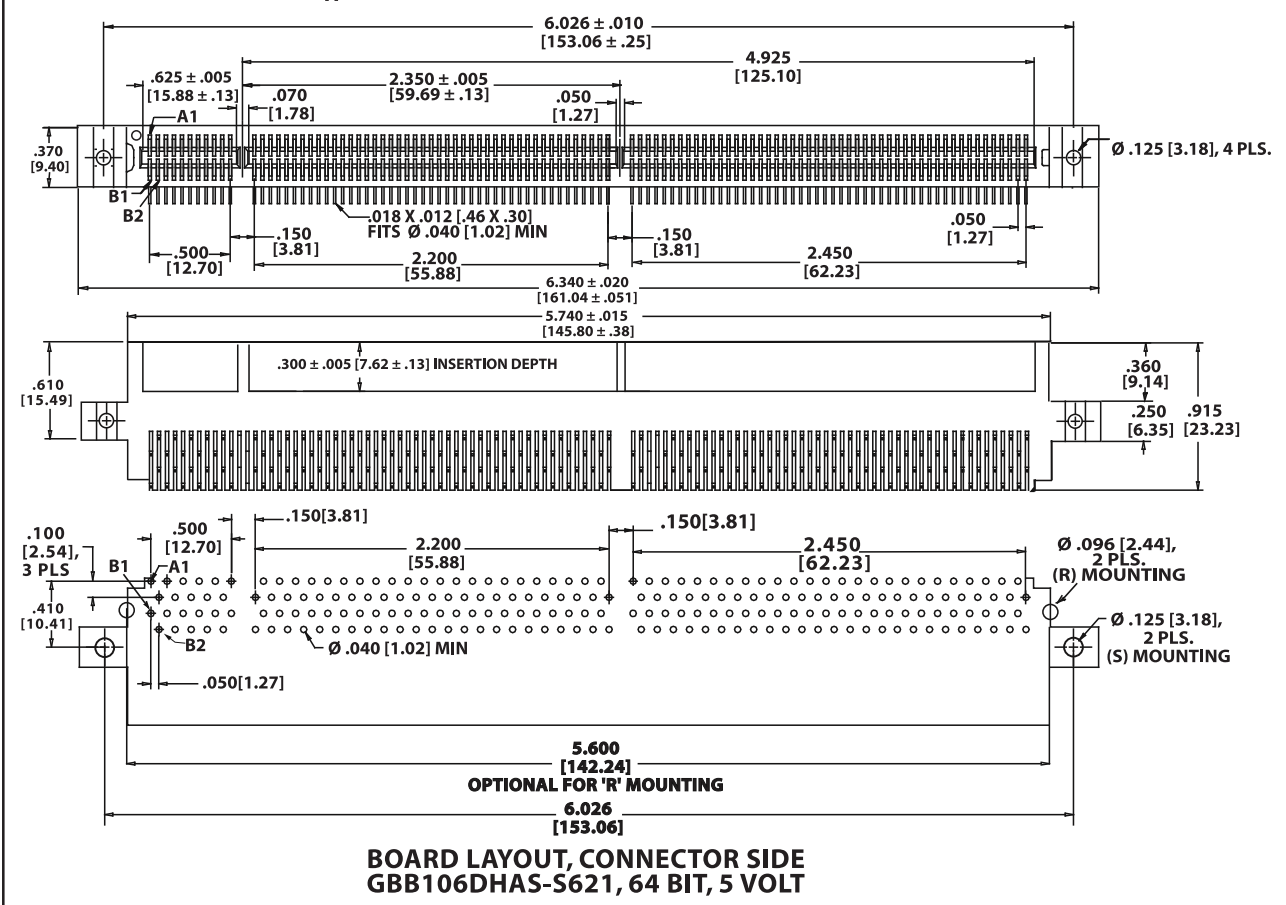

Sullins High Density



**SPECIFICATIONS**

- Accommodates .062" ± .008" [1.57 ± .20] PC board
- PPS or PA9T insulator
- Molded-in key available
- High reliability/high cycle hairpin bellows contact
- 1 amp current rating per contact
- UL Flammability Rating: 94V-0

**READOUT**



**DUAL (D)**

**DIMENSIONS**

Dimensions in [ ] are in millimeters, all others are in inches.

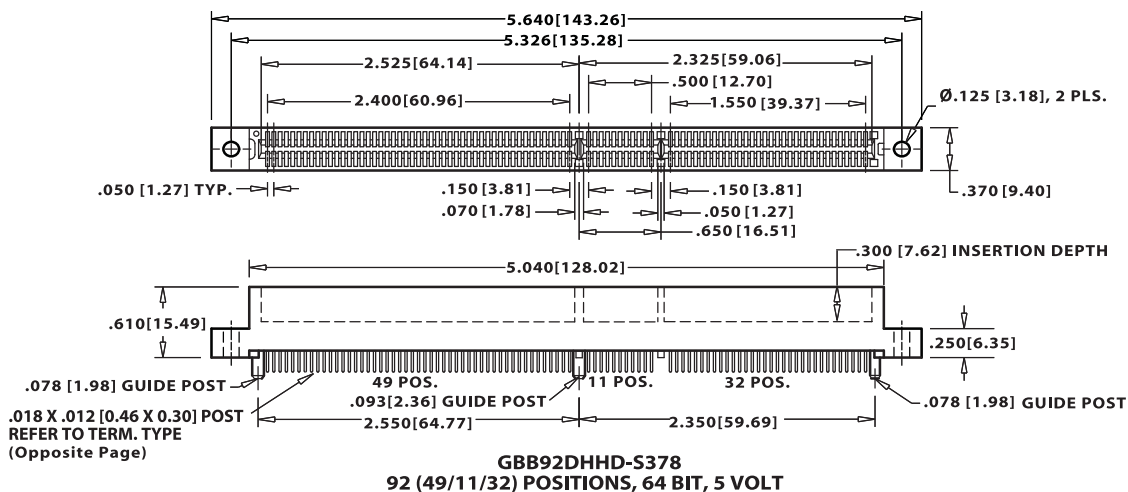
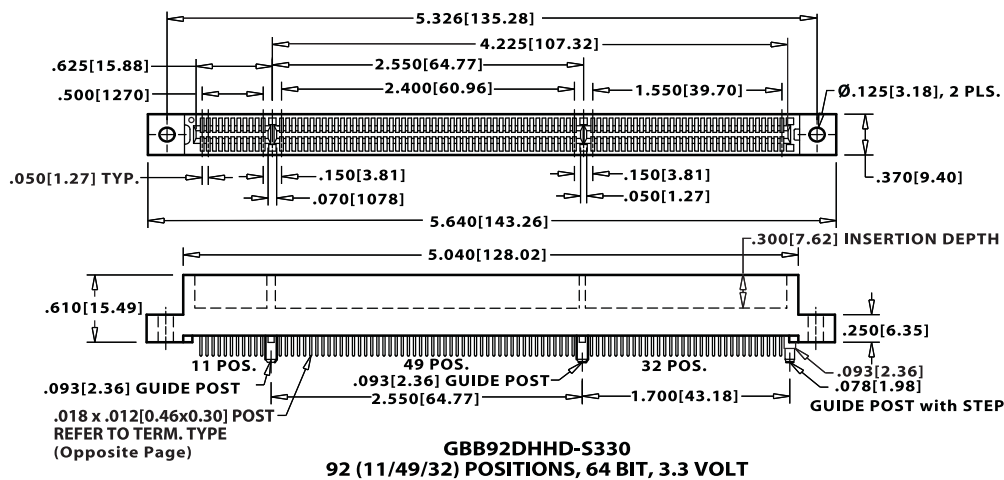
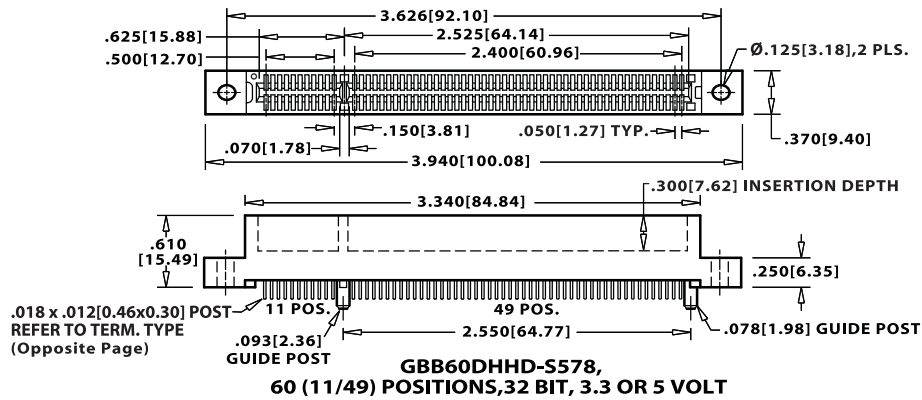



**.050" [1.27mm] Contact Centers, .610" [15.49 mm] Insulator Height  
[PCI] Dip Solder/Card Extender/SMT**

Industry Standard Part

**PART NUMBER OPTIONS**

**MATERIALS (Insulator/Contact)**

- G = PA9T/Phosphor Bronze
- R = PPS/Phosphor Bronze
- J = PA9T/Beryllium Copper
- A = PPS/Beryllium Copper

**CONTACT FINISH - RoHS Compliant**

All platings are Lead Free and have .000050" Nickel underplate

	Contact Surface	Termination
B =	.000010" Gold	.000100" Pure Tin, Matte
C =	.000030" Gold	.000100" Pure Tin, Matte

**CONTACT CENTERS**

- B = .050" [1.27mm]

**NUMBER OF CONTACT POSITIONS**

- \*60 = 11/49 (32 Bit, 3.3 or 5 Volt)
- 92 = 11/49/32 (64 Bit, 3.3 Volt)
- 92 = 49/11/32 (64 Bit, 5 Volt)

**READOUT**

- D = Dual

**G B B 60 D HH D - S578**

**MODIFICATION (CONSULT FACTORY)**

**PCI WITH GUIDE POSTS**

- \*-S578 = 60 (11/49) Positions(32 Bit, 3.3, 5 Volt)
- S330 = 92 (11/49/32) Positions(64 Bit, 3.3 Volt)
- S378 = 92 (49/11/32) Positions(64 Bit, 5 Volt)

**PCI WITHOUT GUIDE POSTS**

- \*-S621 = 60 (11/49) Positions(32 Bit, 3.3 or 5 Volt)
- S329 = 92 (11/49/32) Positions(64 Bit, 3.3 Volt)
- S250 = 92 (49/11/32) Positions(64 Bit, 5 Volt)
- \* Turn connector or board 180° for 3.3 or 5 Volt

**MOUNTING STYLE**

- D = Flush Mounting
- N = No Mounting
- T = Flush Mounting With Threaded Insert
- Q = Straddle Mount (Card Extender Only)
- R = Metal Board locks

**TERMINATION TYPE**

- HH = Staggered Dip Solder
- HR = Card Extender
- HF = Surface Mount
- HL = .250" [6.35mm] x .160" [4.06mm] Dip Solder
- HN = .100" [2.54mm] x .125" [3.18mm] Dip Solder
- (REPLACES TERMINATIONS: CH, CR, CF, CL, CN)

\*Turn connector or board 180° for 3.3 or 5 Volt



FOR PC BOARD LAYOUTS REFER TO [www.sullinscorp.com](http://www.sullinscorp.com)

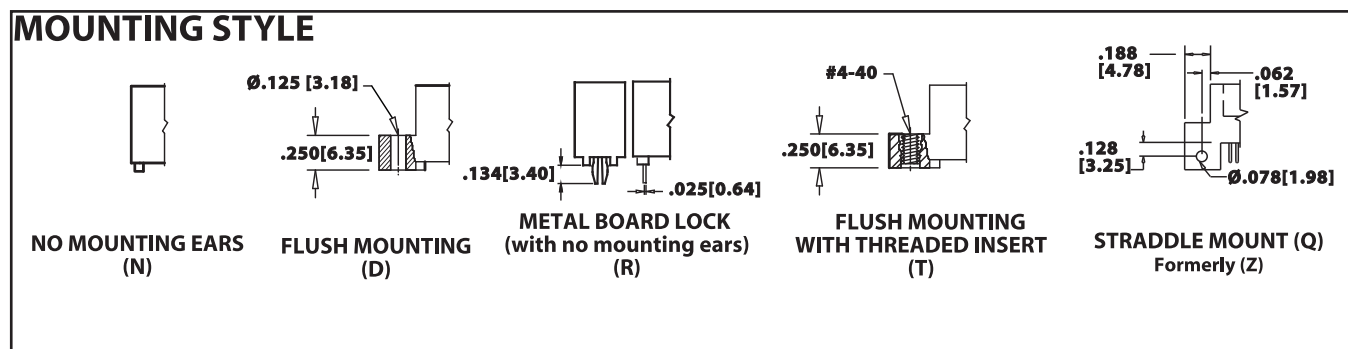
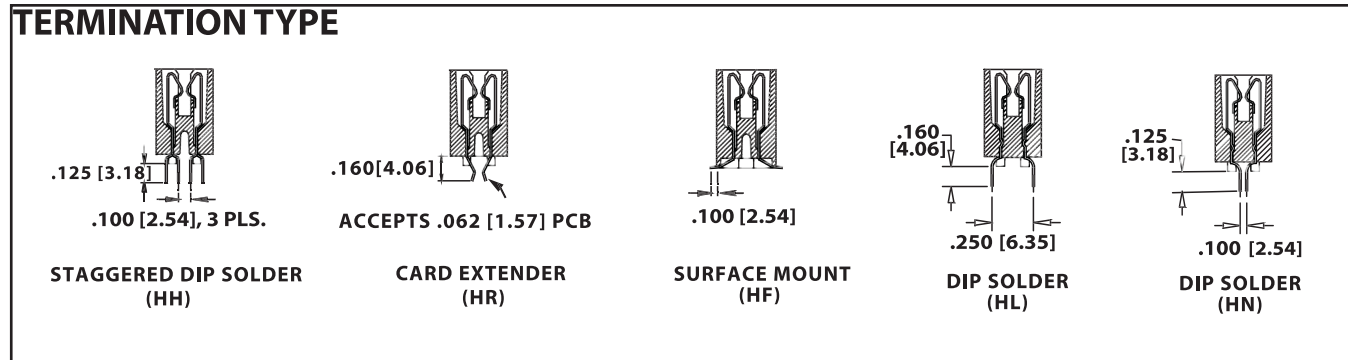



SPECIFICATIONS

- Accommodates .062" ± .008" [1.57 ± .20] PC board
- PPS or PA9T insulator
- Molded-in key available
- High reliability/high cycle Hairpin bellows contact
- 1 amp current rating per contact
- UL Flammability Rating: 94V-0

Sullins High Density

DIMENSIONS

Dimensions in [ ] are in millimeters, all others are in inches.

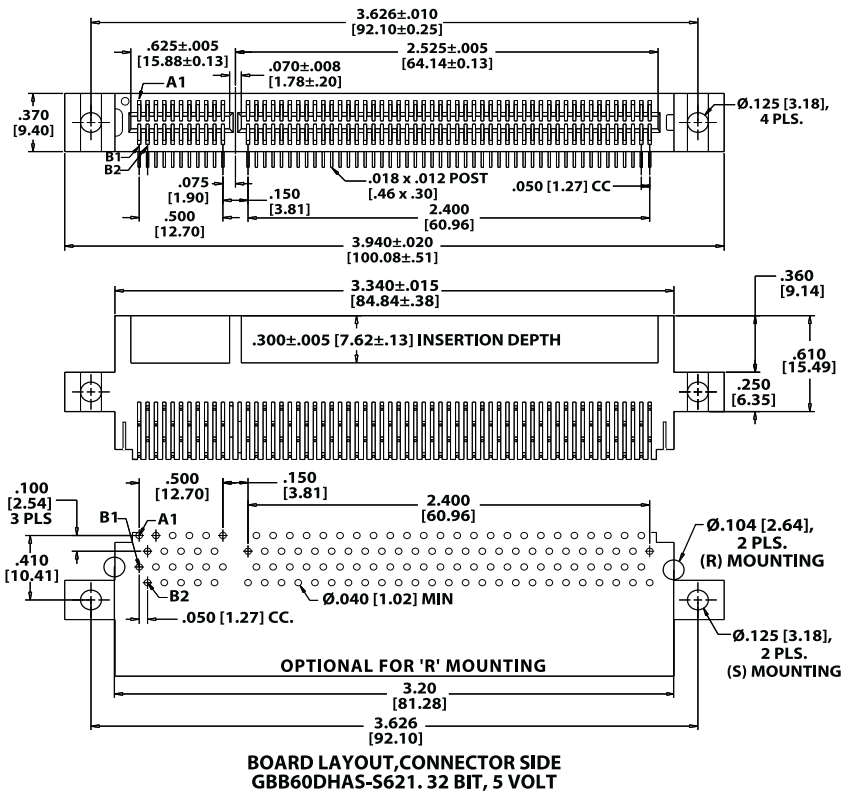

TERMINATION TYPE

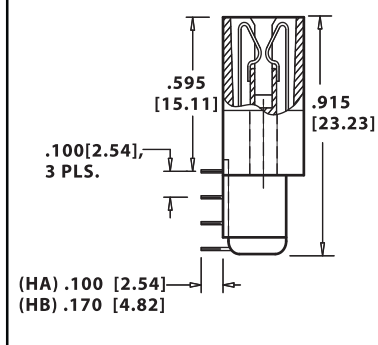

DIMENSIONS

Dimensions in [ ] are in millimeters, all others are in inches.

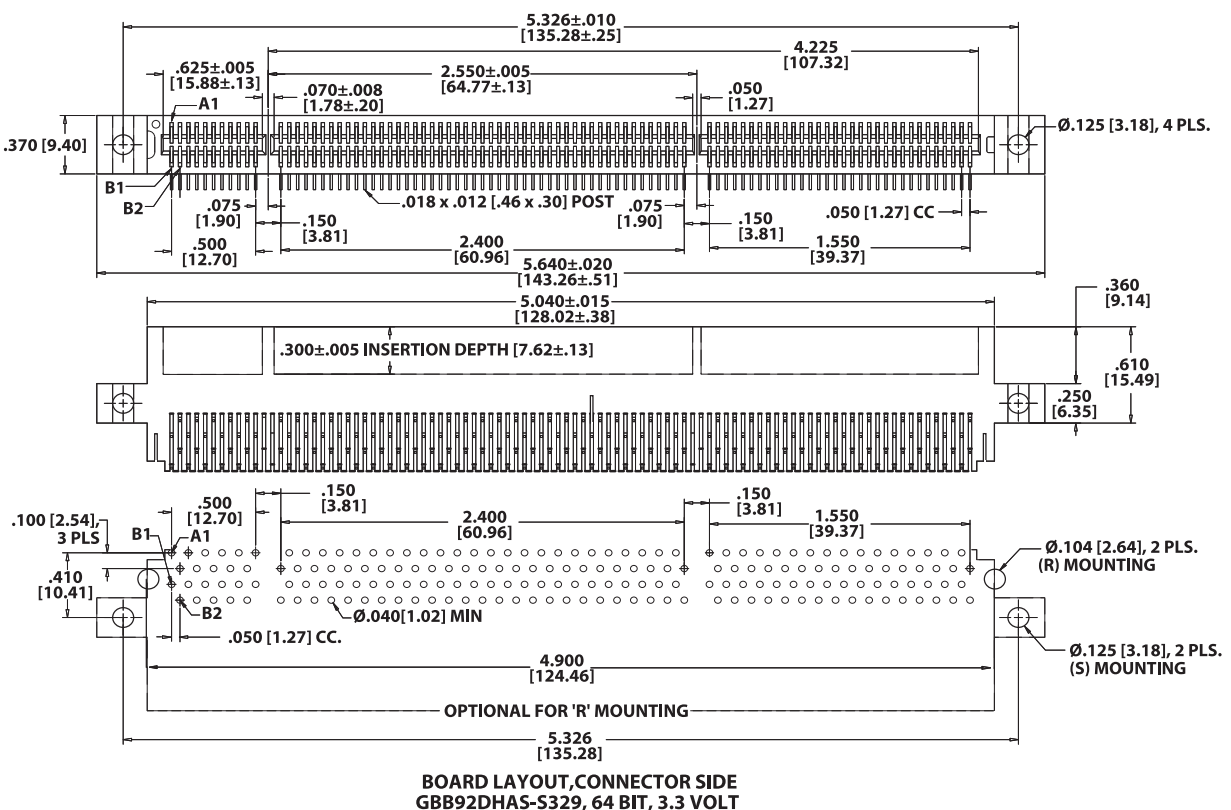

Industry Standard Part



Sullins High Density

**PART NUMBER OPTIONS**

**MATERIALS (Insulator/Contact)**

- G = PA9T/Phosphor Bronze
- R = PPS/Phosphor Bronze
- J = PA9T/Beryllium Copper
- A = PPS/Beryllium Copper

**CONTACT FINISH - RoHS Compliant**

All platings are Lead Free and have .000050" Nickel underplate

- |                        |                          |
|------------------------|--------------------------|
| <b>Contact Surface</b> | <b>Termination</b>       |
| B = .000010" Gold      | .000100" Pure Tin, Matte |
| C = .000030" Gold      | .000100" Pure Tin, Matte |

**CONTACT CENTERS**

- B = .050" [1.27mm]

**NUMBER OF CONTACT POSITIONS**

- 60 = 11/49 (32 Bit, 3.3 or 5 Volt)
- 92 = 11/49/32 (64 Bit, 3.3 Volt)
- or 92 = 49/11/32 (64 Bit, 5 Volt)

**G B B 60 D HA D - S793**

**MODIFICATION (CONSULT FACTORY)**

- S793 = 60(11/49) Reverse Bend (32 Bit, 3.3 Volt)
- S621 = 60(11/49) Positions (32 Bit, 5 Volt)
- S329 = 92(11/49/32) Positions (64 Bit, 3.3 Volt)
- S250 = 92(49/11/32) Positions (64 Bit, 5 Volt)

**MOUNTING STYLE**

- S = Side Mounting
- D = Flush Mounting
- N = No Mounting
- T = Flush Mounting With Threaded Insert
- R = Metal Board Lock

**TERMINATION TYPE (Opposite Page)**

- HA = .100" [2.54mm] Staggered Dip Solder
- HB = .170" [4.32mm] Staggered Dip Solder

**READOUT**

- D = Dual

**DIMENSIONS**

Dimensions in [ ] are in millimeters, all others are in inches.

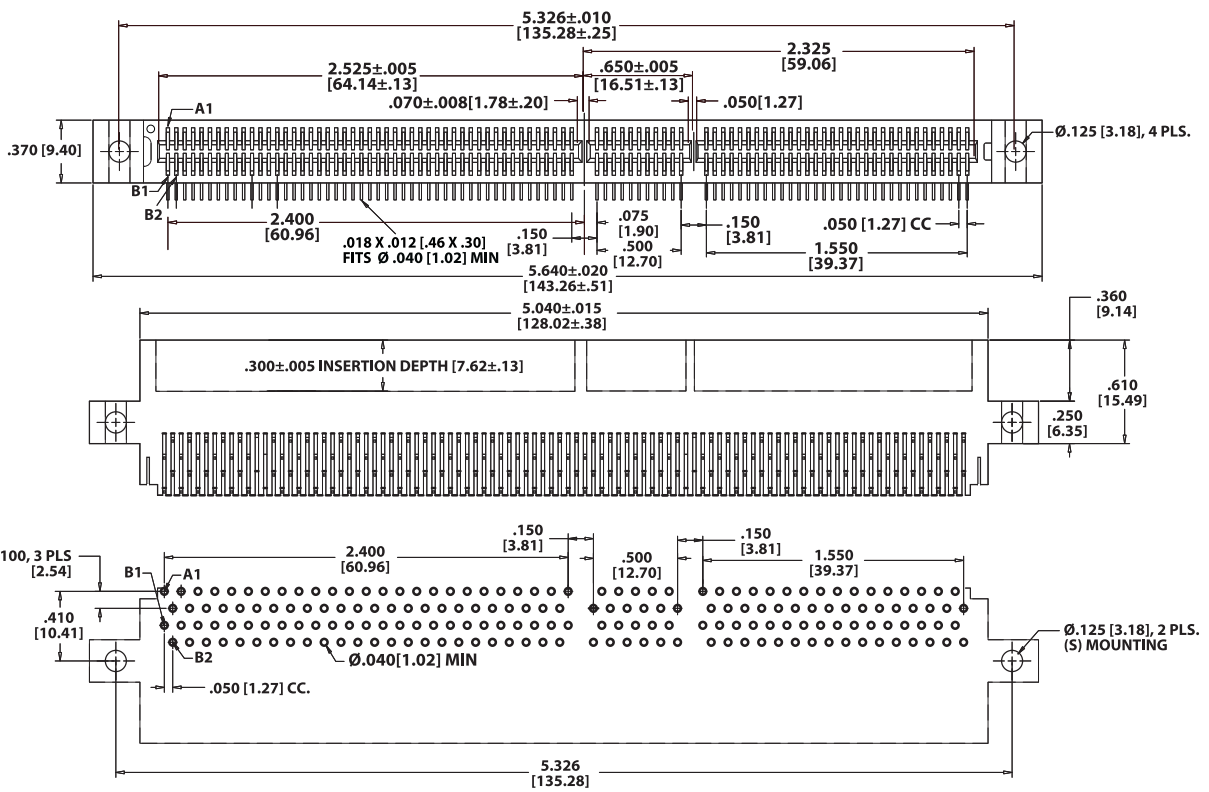

**BOARD LAYOUT, CONNECTOR SIDE  
G B B 92 D H A S - S250, 64 BIT, 5 VOLT**

**MOUNTING STYLE**

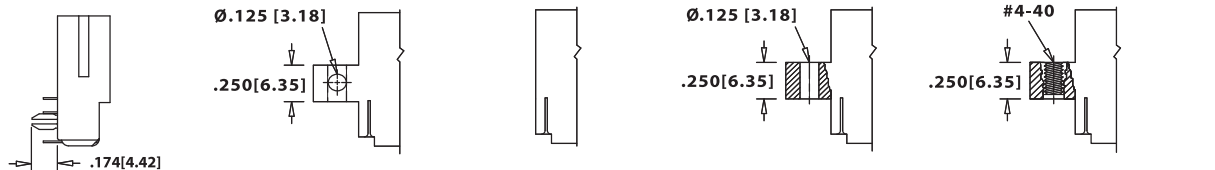

**BOARD LOCK (R) (with no mounting ears)    SIDE MOUNTING (S)    NO MOUNTING EARS (N)    FLUSH MOUNTING (D)    THREADED INSERT (T)**



**Bi-Level, .050" [1.27 mm] / .100" [2.54 mm] Contact Centers**

**High Density, Card Extender, Dip Solder for .062" [1.57] or .093" [2.36]**

**SPECIFICATIONS**

- .050" Contact Center Spacing can replace .100" CC parts to double the number of contacts within the same area
- Backwards Compatible with Daughter Card Side
- Accommodates .062" ± .008" [1.57 ± .20] or .093" ± .008" [2.36 ± .20] PC board
- Contact Material: Beryllium Copper or Phosphor Bronze
- Body Material: PA9T
- UL Flammability: 94V-0
- 3 amp current rating per contact
- Voltage Rating: 225 VAC Minimum at sea level
- Consult Factory for PC board layouts/technical drawings

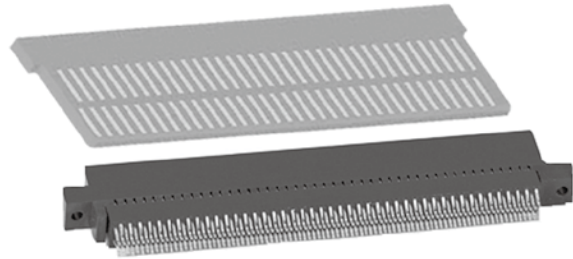

**HIGH DENSITY    HIGH TEMPERATURE    HIGH CYCLE    HIGH RELIABILITY**

**DIMENSIONS**

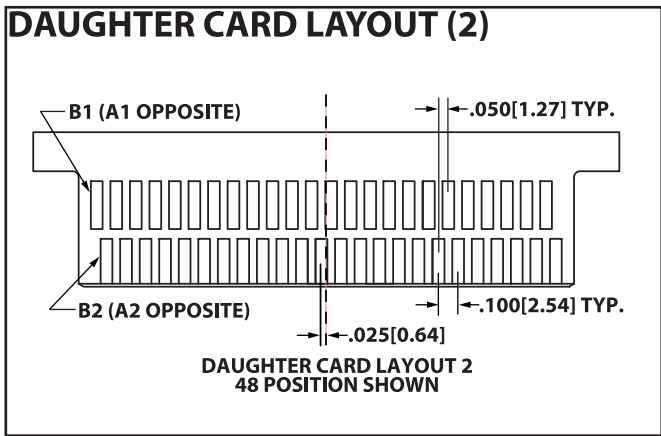
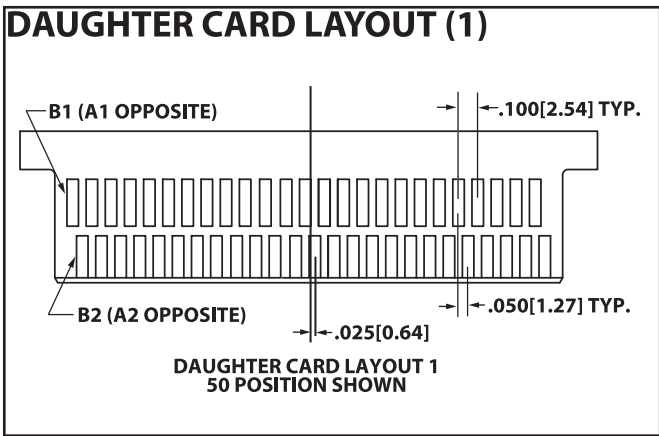
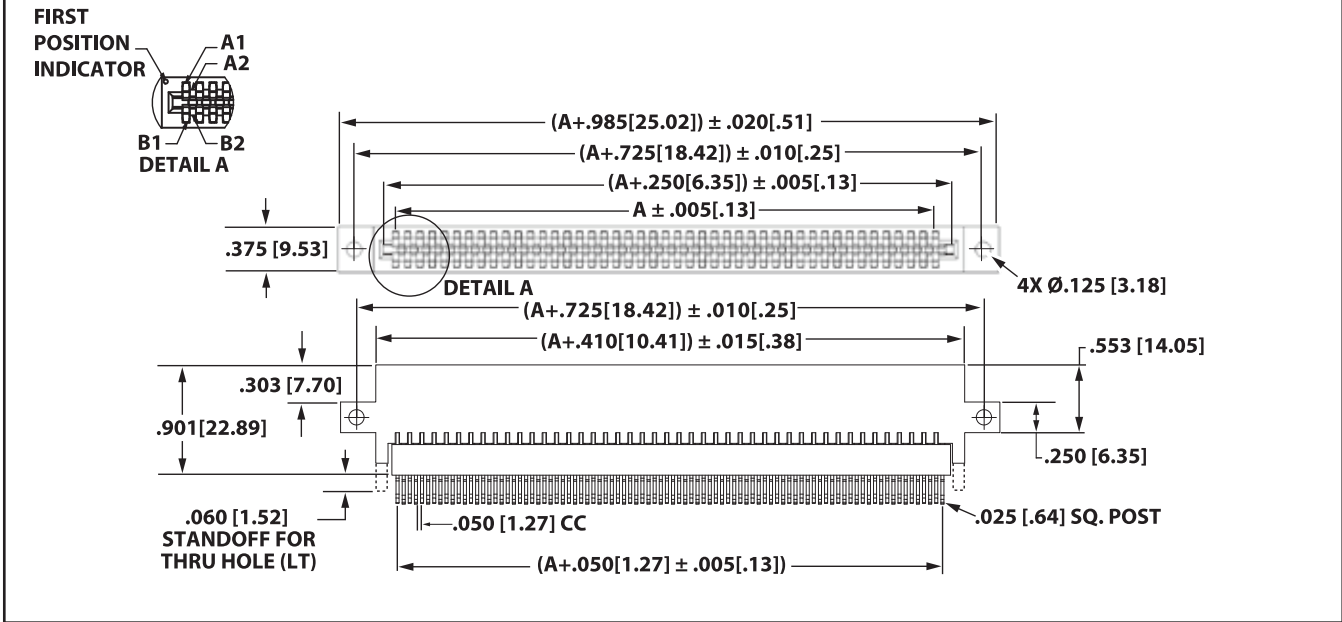



**Bi-Level, .050" [1.27 mm] / .100" [2.54 mm] Contact Centers**  
**High Density, Card Extender, Dip Solder for .062" [1.57] or .093" [2.36]**

**PART NUMBER OPTIONS**

**MATERIALS (INSULATOR/CONTACT)**

- G = PA9T/Phosphor Bronze  
Operating Temperature: 125°C
- J = PA9T/Beryllium Copper  
Operating Temperature: 150°C

**CONTACT FINISH - RoHS Compliant**

All platings are Lead Free and have .000050" Nickel underplate

- |     |                        |                          |
|-----|------------------------|--------------------------|
|     | <b>Contact Surface</b> | <b>Termination</b>       |
| B = | .000010" Gold          | .000100" Pure Tin, Matte |
| C = | .000030" Gold          | .000100" Pure Tin, Matte |
| Y = | .000030" Gold          | .000005" Gold            |

**CONTACT CENTERS**

- B = .050" [1.27mm]

**J C B 10 D LT H - Sxxx**

**MODIFICATION CODE (Consult Factory)**  
OMIT FOR STANDARD

- S1176 = For .093"±.008"  
[2.36 ± .20]  
Thick Mating PCB

Positions	Dimension A (see opposite page)			Daughter Card Layout
	No. of Contacts	Inches	[MM]	
06	12	0.200	5.08	1
08*	16	0.300	7.62	2
10	20	0.400	10.16	1
12	24	0.500	12.70	2
14*	28	0.600	15.24	1
16*	32	0.700	17.78	2
18*	36	0.800	20.32	1
20	40	0.900	22.86	2
22*	44	1.000	25.40	1
24	48	1.100	27.94	2
26*	52	1.200	30.48	1
28*	56	1.300	33.02	2
30	60	1.400	35.56	1
32*	64	1.500	38.10	2
34	68	1.600	40.64	1
36	72	1.700	43.18	2
38*	76	1.800	45.72	1
40	80	1.900	48.26	2
42*	84	2.000	50.80	1
44	88	2.100	53.34	2
46*	92	2.200	55.88	1
48*	96	2.300	58.42	2
50	100	2.400	60.96	1
52	104	2.500	63.50	2
54*	108	2.600	66.04	1
56	112	2.700	68.58	2
58*	116	2.800	71.12	1
60	120	2.900	73.66	2
62*	124	3.000	76.20	1
64*	128	3.100	78.74	2
66*	132	3.200	81.28	1
68*	136	3.300	83.82	2
70	140	3.400	86.36	1
72	144	3.500	88.90	2
74*	148	3.600	91.44	1
76	152	3.700	93.98	2
78	156	3.800	96.52	1
80	160	3.900	99.06	2
82*	164	4.000	101.60	1
84*	168	4.100	104.14	2
86	172	4.200	106.68	1
88*	176	4.300	109.22	2
90	180	4.400	111.76	1

\* Consult Factory For Availability.

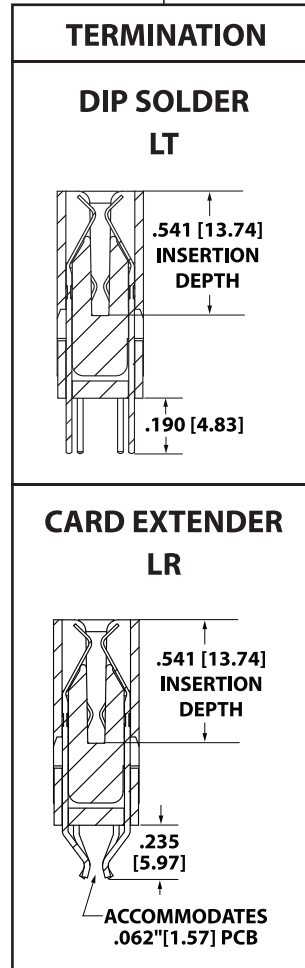

MOUNTING STYLE		
H	MOUNTING HOLES	Ø .125 [3.18]
S	SIDE MOUNTING HOLES	Ø .125 [3.18]
I	#4-40 THREADED INSERTS	#4 - 40
A	#4-40 THREADED INSERTS IN SIDE HOLES	#4 - 40
Z	FLUSH EARS WITH SIDE MOUNTING HOLES	Ø .125 [3.18]
D	FLUSH EARS WITH Ø.125 HOLES	Ø .125 [3.18]
T	FLUSH EARS WITH #4-40 THREADED INSERTS	#4 - 40
V	FLUSH EARS WITH #4-40 THREADED INSERTS IN SIDE HOLES	#4 - 40
N	NO MOUNTING EARS	

Sullins Bi-Level



**Bi-Level, .050" [1.27 mm] / .100" [2.54 mm] Contact Centers**  
**High Density, Right Angle for .062" [1.57] or .093" [2.36]**

**SPECIFICATIONS**

- .050" Contact Center Spacing can replace .100" CC parts to double the number of contacts within the same area
- Backwards Compatible with Daughter Card Side
- Accommodates .062" ± .008" [1.57 ± .20] or .093" ± .008" [2.36 ± .20] PC board
- Contact Material: Beryllium Copper or Phosphor Bronze
- Body Material: PA9T
- UL Flammability: 94V-0
- 3 amp current rating per contact
- Voltage Rating: 225 VAC Minimum at sea level
- Consult Factory for PC board layouts/technical drawings

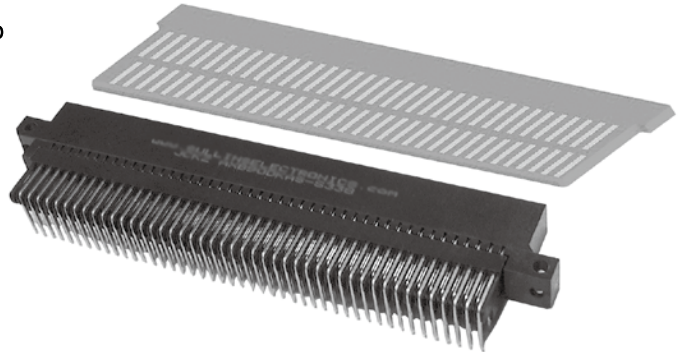

Sullins Bi-Level

**TERMINATION TYPE**

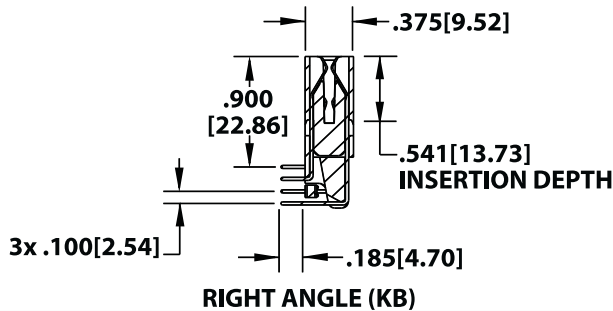

- HIGH DENSITY**
- HIGH TEMPERATURE**
- HIGH CYCLE**
- HIGH RELIABILITY**

**DIMENSIONS**

Dimensions in [ ] are in millimeters, all others are in inches.

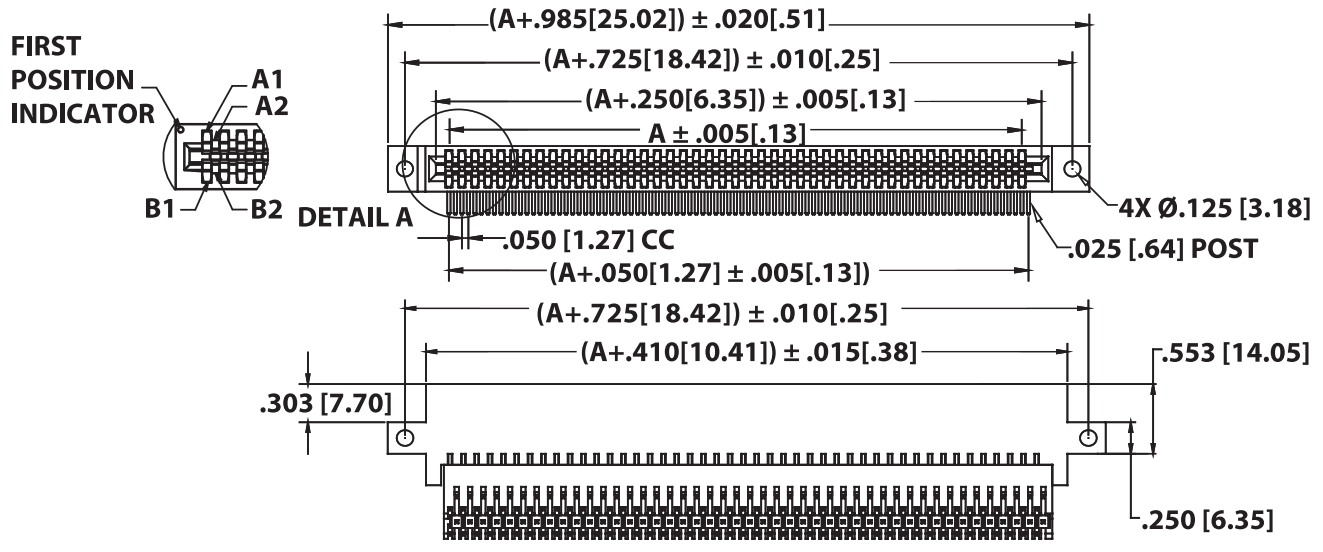

**DAUGHTER CARD LAYOUT (1)**

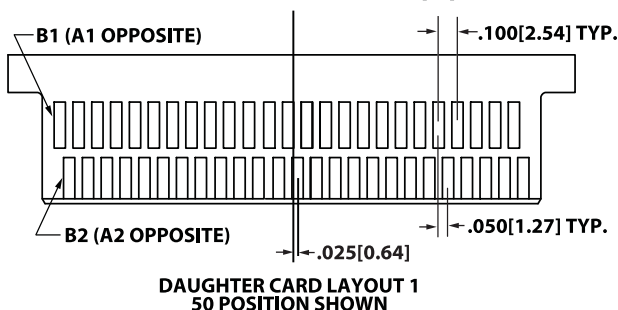

**DAUGHTER CARD LAYOUT (2)**

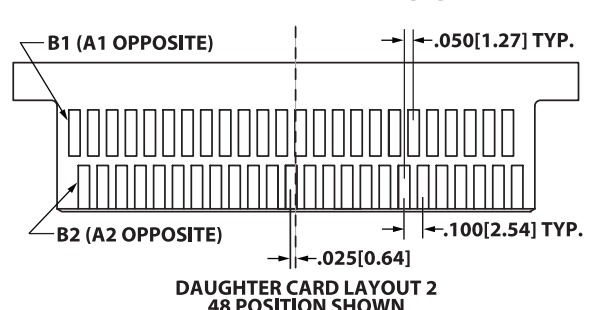



**Bi-Level, .050" [1.27 mm] / .100" [2.54 mm] Contact Centers**  
**High Density, Right Angle for .062" [1.57] or .093" [2.36]**

**PART NUMBER OPTIONS**

J C B 10 D KB S - S1075

**MATERIALS (INSULATOR/CONTACT)**

- G = PA9T/Phosphor Bronze  
Operating Temperature: 125°C
- J = PA9T/Beryllium Copper  
Operating Temperature: 150°C

**CONTACT FINISH - RoHS Compliant**

All platings are Lead Free and have .000050" Nickel underplate  
**Contact Surface Termination**

- B = .000010" Gold .000100" Pure Tin, Matte
- C = .000030" Gold .000100" Pure Tin, Matte
- Y = .000030" Gold .000005" Gold

**CONTACT CENTERS**

- B = .050" [1.27mm]

OMIT FOR STANDARD

- S1176 = For .093" ± .008" [2.36 ± .20]  
Thick Mating PCB
- S - S1075 = Staggered Ears with Side Mounting Holes
- A - S1076 = Staggered Ears with #4-40 Threaded Inserts

Positions	Dimension A (see opposite page)			Daughter Card Layout
	No. of Contacts	Inches	[MM]	
06	12	0.200	5.08	1
08*	16	0.300	7.62	2
10	20	0.400	10.16	1
12	24	0.500	12.70	2
14*	28	0.600	15.24	1
16*	32	0.700	17.78	2
18*	36	0.800	20.32	1
20	40	0.900	22.86	2
22*	44	1.000	25.40	1
24	48	1.100	27.94	2
26*	52	1.200	30.48	1
28*	56	1.300	33.02	2
30	60	1.400	35.56	1
32*	64	1.500	38.10	2
34	68	1.600	40.64	1
36	72	1.700	43.18	2
38*	76	1.800	45.72	1
40	80	1.900	48.26	2
42*	84	2.000	50.80	1
44	88	2.100	53.34	2
46*	92	2.200	55.88	1
48*	96	2.300	58.42	2
50	100	2.400	60.96	1
52	104	2.500	63.50	2
54*	108	2.600	66.04	1
56	112	2.700	68.58	2
58*	116	2.800	71.12	1
60	120	2.900	73.66	2
62*	124	3.000	76.20	1
64*	128	3.100	78.74	2
66*	132	3.200	81.28	1
68*	136	3.300	83.82	2
70	140	3.400	86.36	1
72	144	3.500	88.90	2
74*	148	3.600	91.44	1
76	152	3.700	93.98	2
78	156	3.800	96.52	1
80	160	3.900	99.06	2
82*	164	4.000	101.60	1
84*	168	4.100	104.14	2
86	172	4.200	106.68	1
88*	176	4.300	109.22	2
90	180	4.400	111.76	1

\* Consult Factory For Availability.

MOUNTING STYLE		
H	MOUNTING HOLES	
S	SIDE MOUNTING HOLES	
I	#4-40 THREADED INSERTS	
A	#4-40 THREADED INSERTS IN SIDE HOLES	
Z	FLUSH EARS WITH SIDE MOUNTING HOLES	
D	FLUSH EARS WITH Ø.125 HOLES	
T	FLUSH EARS WITH #4-40 THREADED INSERTS	
V	FLUSH EARS WITH #4-40 THREADED INSERTS IN SIDE HOLES	
N	NO MOUNTING EARS	

**MODIFICATION CODE**  
(CONSULT FACTORY)

**STAGGERED EARS WITH SIDE MOUNTING HOLES (S-S1075)**

**STAGGERED EARS WITH #4-40 THREADED INSERTS (A-S1076)**

Sullins Bi-Level



**Bi-Level, .078" [1.98 mm] / .156" [3.96 mm] Contact Centers  
High Density, Right Angle**

**SPECIFICATIONS**

- .078" Contact Center Spacing can replace .156" CC parts to double the number of contacts within the same area
- Backwards Compatible with Daughter Card Side
- Accommodates .062" ± .008" [1.57 ± .20] PC board
- Contact Material: Beryllium Copper or Phosphor Bronze
- Body Material: PA9T
- UL Flammability: 94V-0
- 3 amp current rating per contact
- 75 grams minimum contact normal force
- Voltage Rating: 125 VDC Minimum at sea level
- Consult Factory for PC board layouts/technical drawings

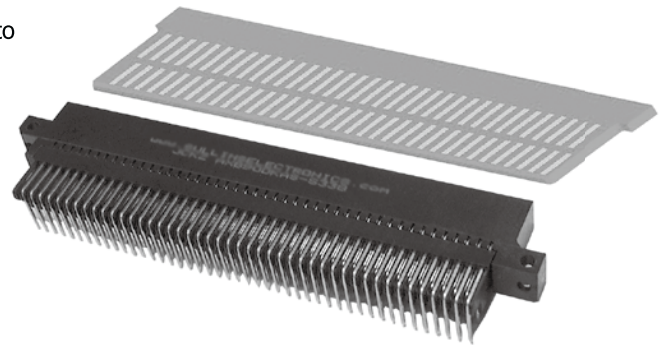

Sullins Bi-Level

**TERMINATION TYPE**

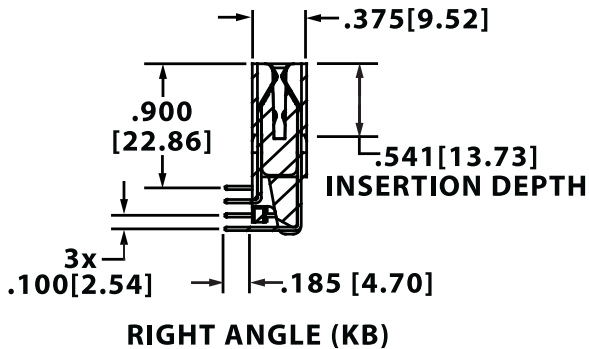

- HIGH DENSITY**
- HIGH TEMPERATURE**
- HIGH CYCLE**
- HIGH RELIABILITY**

**DIMENSIONS**

Dimensions in [ ] are in millimeters, all others are in inches.

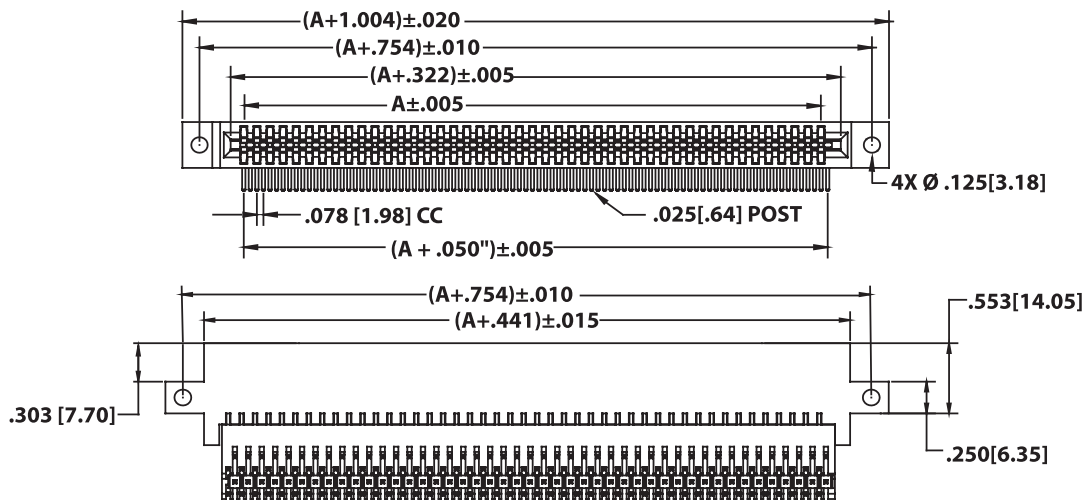

**DAUGHTER CARD LAYOUT**

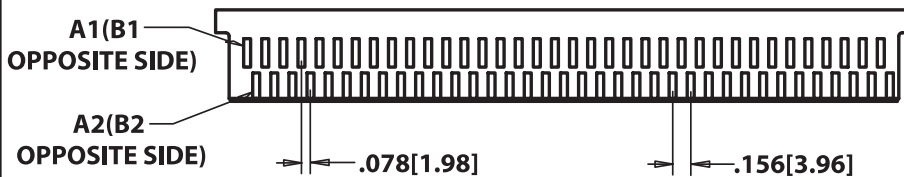

**DAUGHTER CARD  
SIDE VIEW**

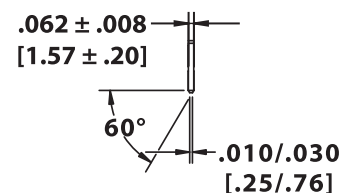



**PART NUMBER OPTIONS**

**MATERIALS (INSULATOR/CONTACT)**

- G = PA9T/Phosphor Bronze  
Operating Temperature: 125°C
- J = PA9T/Beryllium Copper  
Operating Temperature: 150°C

**CONTACT FINISH - RoHS Compliant**

All platings are Lead Free and have .000050" Nickel underplate  
**Contact Surface Termination**

- B = .000010" Gold .000100" Pure Tin, Matte
- C = .000030" Gold .000100" Pure Tin, Matte
- Y = .000030" Gold .000005" Gold

**CONTACT CENTERS**

- K = .078" [1.98mm]

J C K 10 D KB S - Sxxx

OMIT FOR STANDARD  
S - S1075 = Staggered Ears with Side Mounting Holes  
A - S1076 = Staggered Ears with #4-40 Threaded Inserts

POSITIONS	Dimension A (See Opposite Page)		
	No. of Contacts	Inches	[MM]
06*	12	0.780	19.81
08*	16	1.092	27.74
10*	20	1.404	35.66
12*	24	1.716	43.59
14*	28	2.028	51.51
16*	32	2.340	59.44
18*	36	2.652	67.36
20	40	2.964	75.29
22*	44	3.276	83.21
24*	48	3.588	91.14
26*	52	3.900	99.06
28*	56	4.212	106.98
30*	60	4.524	114.91
32*	64	4.836	122.83
34*	68	5.148	130.76
36*	72	5.460	138.68
38*	76	5.772	146.61
40*	80	6.084	154.53
42*	84	6.396	162.46
44*	88	6.708	170.38
46*	92	7.020	178.31
48*	96	7.332	186.23
50*	100	7.644	194.16
52*	104	7.956	202.08
54*	108	8.268	210.01
56*	112	8.580	217.93
58*	116	8.892	225.86
60*	120	9.204	233.78
62*	124	9.516	241.71
64*	128	9.828	249.63
66*	132	10.140	257.56
68*	136	10.452	265.48
70*	140	10.764	273.41
72*	144	11.076	281.33

MOUNTING STYLE		
H	MOUNTING HOLES	
S	SIDE MOUNTING HOLES	
I	#4-40 THREADED INSERTS	
A	#4-40 THREADED INSERTS IN SIDE HOLES	
Z	FLUSH EARS WITH SIDE MOUNTING HOLES	
D	FLUSH EARS WITH Ø.125 HOLES	
T	FLUSH EARS WITH #4-40 THREADED INSERTS	
V	FLUSH EARS WITH #4-40 THREADED INSERTS IN SIDE HOLES	
N	NO MOUNTING EARS	

MODIFICATION CODE
(CONSULT FACTORY)
<b>STAGGERED EARS WITH SIDE MOUNTING HOLES (S-S1075)</b>
<b>STAGGERED EARS WITH #4-40 THREADED INSERTS (A-S1076)</b>

\* Consult Factory For Availability.



**SPECIFICATIONS**

- Accommodates .062" ± .008 [1.57 ± .20] PC board, both sides
- PBT or PPS
- 3 amp current rating
- 30 milli ohm maximum at rated current
- UL Flammability Rating: 94V-0



**READOUT**

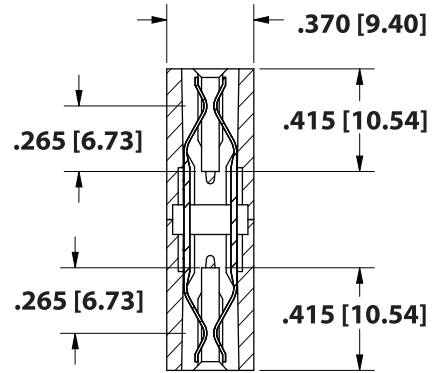

**CROSS SECTION**

**MOUNTING STYLE**

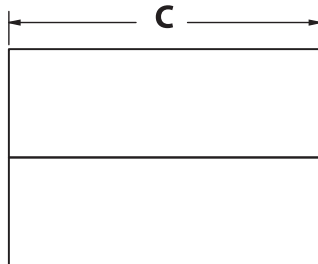

**NO MOUNTING EARS (N)**

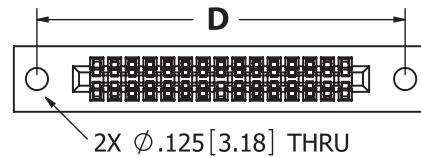

**FLUSH MOUNTING (D)**



**STRADDLE MOUNT (Q)**

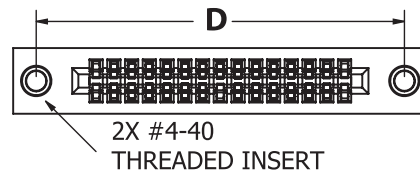

**THREADED INSERT (I)**



**.100" [2.54 mm] Contact Centers, Dual Edge**

**PART NUMBER OPTIONS**

**MATERIALS (Insulator/Contact)**

- E = PBT/Phosphor Bronze (Standard)
- R = PPS/Phosphor Bronze
- H = PBT/Beryllium Copper
- A = PPS/Beryllium Copper

**CONTACT FINISH - RoHS Compliant**

All platings are Lead Free and have .000050" Nickel underplate  
**Contact Surface**

A = .000030" Gold, both ends

**CONTACT CENTERS**

C = .100" [32.54mm]

**NUMBER OF CONTACT POSITIONS**

See Chart Below (Contacts per Row)

**READOUT (Opposite Page)**

F = Dual Edge

**E A C 50 F SL Q - Sxxx**

**MODIFICATION CODE (Consult Factory)**  
OMIT FOR STANDARD

**MOUNTING STYLE (Opposite Page)**

- Q = Saddle Mount
- D = Flush Mounting
- I = Threaded Inserts
- N = No Mounting

**TERMINATION TYPE (Opposite Page)**

SL = Single Level

**DIMENSIONS**

Dimensions in [ ] are in millimeters, all others are in inches

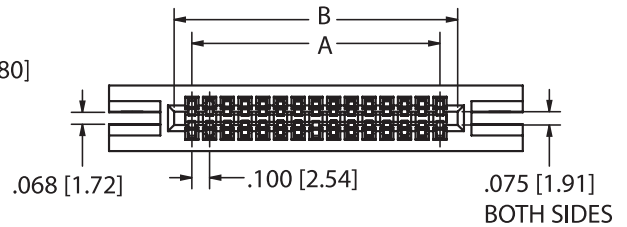
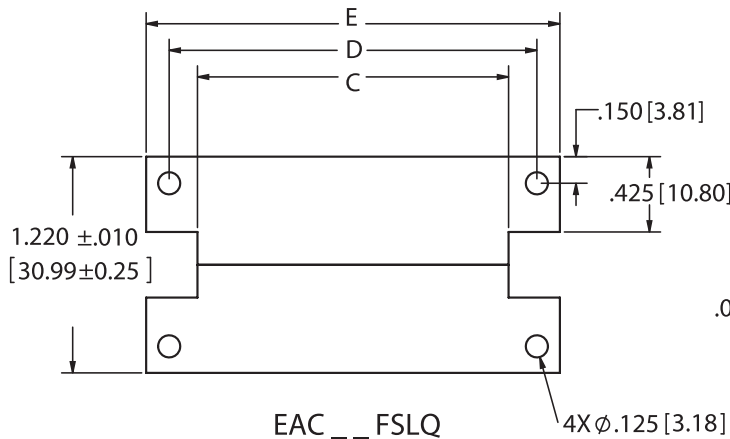

EAC \_\_ FSLQ

VIEW BOTH TOP AND BOTTOM SIDE

PART NUMBER	POSITIONS	A±.008[0.20]		B±.008[0.20]		C±.015[0.38]		D±.010[0.25]		E±.020[0.25]	
		INCH	MM	INCH	MM	INCH	MM	INCH	MM	INCH	MM
--- C05FSL	05	0.400	10.16	0.600	15.24	0.756	19.20	1.075	27.31	1.335	33.91
--- C06FSL	06	0.500	12.70	0.700	17.78	0.856	21.74	1.175	29.85	1.435	36.45
--- C10FSL	10	0.900	22.86	1.100	27.94	1.256	31.90	1.575	40.01	1.835	46.61
--- C12FSL	12	1.100	27.94	1.300	33.02	1.456	36.98	1.775	45.09	2.035	51.69
--- C15FSL	15	1.400	35.56	1.600	40.64	1.756	44.60	2.075	52.71	2.335	59.31
--- C17FSL	17	1.600	40.64	1.800	45.72	1.956	49.68	2.275	57.79	2.535	64.39
--- C18FSL	18	1.700	43.18	1.900	48.26	2.056	52.22	2.375	60.33	2.635	66.93
--- C20FSL	20	1.900	48.26	2.100	53.34	2.256	57.30	2.575	65.41	2.835	72.01
--- C22FSL	22	2.100	53.34	2.300	58.42	2.456	62.38	2.775	70.49	3.035	77.09
--- C25FSL	25	2.400	60.96	2.600	66.04	2.756	70.00	3.075	78.11	3.335	84.71
--- C28FSL	28	2.700	68.58	2.900	73.66	3.056	77.62	3.375	85.73	3.635	92.33
--- C30FSL	30	2.900	73.66	3.100	78.74	3.256	82.70	3.575	90.81	3.835	97.41
--- C35FSL	35	3.400	86.36	3.600	91.44	3.756	95.40	4.075	103.51	4.335	110.11
--- C36FSL	36	3.500	88.90	3.700	93.98	3.856	97.94	4.175	106.05	4.435	112.65
--- C43FSL	43	4.200	106.68	4.400	111.76	4.556	115.72	4.875	123.83	5.135	130.43
--- C50FSL	50	4.900	124.46	5.100	129.54	5.256	133.50	5.575	141.61	5.835	148.21
--- C60FSLN	60	5.900	149.86	6.100	154.94	6.256	158.90	'N' MOUNTING ONLY			

Sullins Dual Edge



# Male Card Edge

**.100" [2.54 mm] Contact Centers, .540" [13.72 mm] Insulator Height**  
**Male Card Edge, Dip Solder/Right Angle/Card Extender**

## SPECIFICATIONS

- Compatible with .431" or .610" Insulator Height Card Edges
- Mates in place of .062" [1.57] PCB
- PBT, PA9T or PPS insulator
- 3 amp current rating
- 30 milli ohm maximum at rated current
- Consult Factory for other Contact Centers
- UL Flammability Rating: 94V-0

### Operating/Processing Temperature

- E** = PBT & Phosphor Bronze  
Operating Temperature: -65°C To +125°C  
Processing Temp: Wave only
- R** = PPS & Phosphor Bronze  
Operating Temperature: -65°C To +150°C  
Processing Temperature: 260°C For 120 Sec. Max.
- G** = PA9T & Phosphor Bronze  
Operating Temperature: -65°C To +150°C  
Processing Temperature: 260° For 20 Sec. Max.
- A** = PPS & Beryllium Copper  
Operating Temperature: -65°C to +200°C  
Processing Temperature: 260°C For 120 Sec. Max.  
Overall Gold Plating Only (Plating code 'S' or 'M')



## TERMINATION TYPE

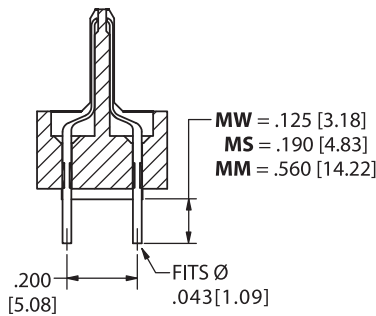

**DIP SOLDER (MW, MS)**  
**WIRE WRAP (MM)**

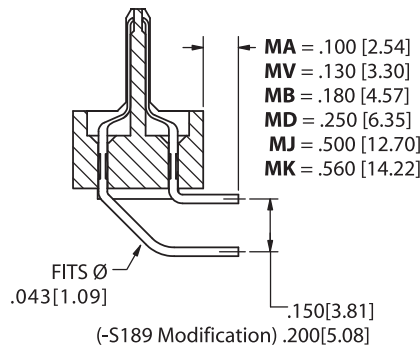

**RIGHT ANGLE**  
**(MA, MV, MB, MD, MJ, MK)**

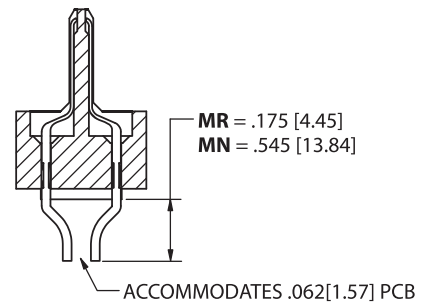

**CARD EXTENDER**  
**(MR, MN)**

## MOUNTING STYLE

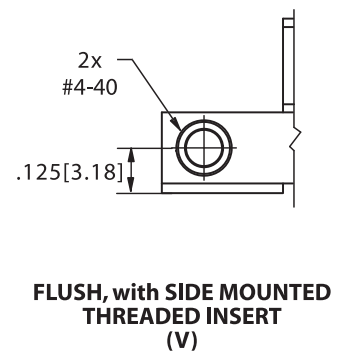
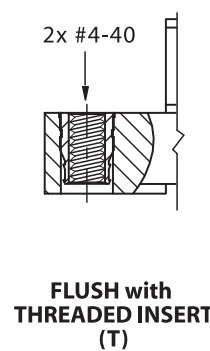
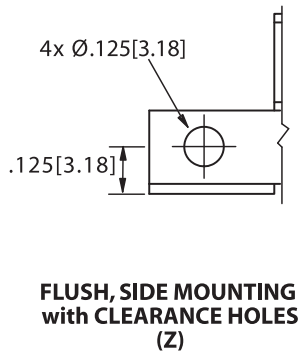
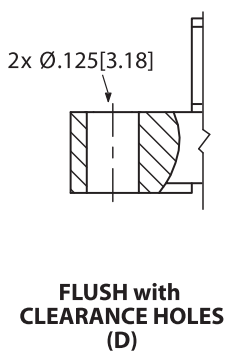
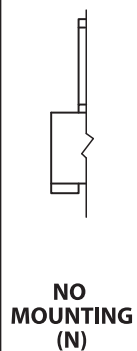



**.100" [2.54 mm] Contact Centers, .540" [13.72 mm] Insulator Height  
Male Card Edge, Dip Solder/Right Angle/Card Extender**

**PART NUMBER OPTIONS**

**MATERIALS (Insulator/Contact)**

- E = PBT/Phosphor Bronze
- G = PA9T/Phosphor Bronze
- R = PPS/ Phosphor Bronze
- A = PPS/Beryllium Copper (Only 'S' or 'M' plating code)

Operating & Processing Temperature: see opposing page

**CONTACT FINISH - RoHS Compliant**

All platings are Lead Free and have .000050" Nickel underplate

<b>Contact Surface</b>		<b>Termination</b>	
B =	.000010" Gold		.000100" Pure Tin, Matte
C =	.000030" Gold		.000100" Pure Tin, Matte
Y =	.000030" Gold		.000005" Gold
<b>Contact Surface</b>		<b>Overall Plating</b>	
S =	.000010" Gold		.000010" Gold
M =	.000030" Gold		.000010" Gold

**CONTACT CENTERS**

C = .100" [2.54mm]

**E B C 25 M MW D - Sxxx**

**MODIFICATIONS (Consult Factory)**

- Omit for Standard
- S189 = .200" Row Spacing (Right Angle Only)

**MOUNTING STYLE (Opposite Page)**

- N = No Mounting
- D = .250" Ears, Flush Mounting, .125" [3.18mm] Dia
- Z = .250" Ears, Flush, Side Mounting
- T = .250" Ears, Flush Mounting, #4-40 Threaded Insert
- V = Flush, Side Mounting, #4-40 Threaded Insert

**TERMINATION TYPE (Opposite Page)**

- MW, MS = Dip Solder
- MM = Wire Wrap
- MA, MV, MB = Right Angle
- MD, MJ, MK = Right Angle
- MR, MN = Card Extender
- M = Male Card Edge**

**NUMBER OF CONTACT POSITIONS**

04 thru 60 Positions (Contact Factory for Positions Not Shown)

**DIMENSIONS**

Dimensions in [ ] are in millimeters, all others are in inches.

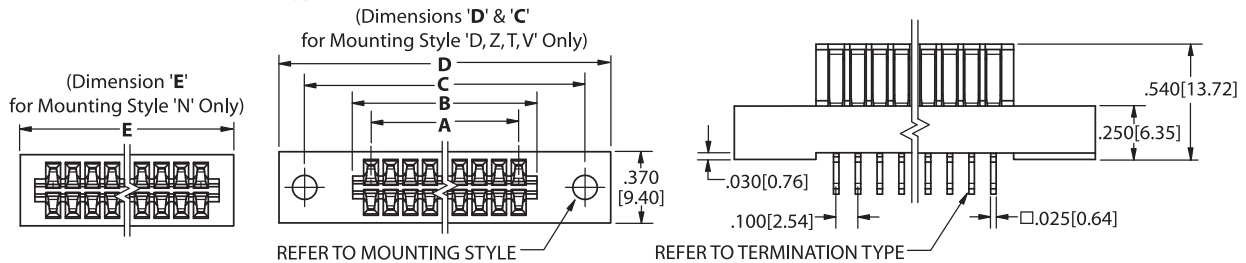

POSITIONS/ CONTACTS	INCHES					[MILLIMETERS]				
	A±.008	B±.008	C±.010	D±.020	E±.020 'N' Mtg. Only	A±0.20	B±0.20	C±0.25	D±0.51	E±0.51 'N' Mtg. Only
04/08	0.300	0.486	0.975	1.236	0.656	7.62	12.34	24.77	31.39	16.66
05/10	0.400	0.586	1.075	1.336	0.756	10.16	14.88	27.31	33.93	19.20
06/12	0.500	0.686	1.175	1.436	0.856	12.70	17.42	29.85	36.47	21.74
07/14*	0.600	0.786	1.275	1.536	0.956	15.24	19.96	32.39	39.01	24.28
08/16*	0.700	0.886	1.375	1.636	1.056	17.78	22.50	34.93	41.55	26.82
10/20	0.900	1.086	1.575	1.836	1.256	22.86	27.58	40.01	46.63	31.90
12/24	1.100	1.286	1.775	2.036	1.456	27.94	32.66	45.09	51.71	36.98
13/26*	1.200	1.386	1.875	2.136	1.556	30.48	35.20	47.63	54.25	39.52
15/30	1.400	1.586	2.075	2.336	1.756	35.56	40.28	52.71	59.33	44.60
17/34	1.600	1.786	2.275	2.536	1.956	40.64	45.36	57.79	64.41	49.68
18/36	1.700	1.886	2.375	2.636	2.056	43.18	47.90	60.33	66.95	52.22
19/38	1.800	1.986	2.475	2.736	2.156	45.72	50.44	62.87	69.49	54.76
20/40	1.900	2.086	2.575	2.836	2.256	48.26	52.98	65.41	72.03	57.30
22/44	2.100	2.286	2.775	3.036	2.456	53.34	58.06	70.49	77.11	62.38
23/46	2.200	2.386	2.875	3.136	2.556	55.88	60.60	73.03	79.65	64.92
24/48	2.300	2.486	2.975	3.236	2.656	58.42	63.14	75.57	82.19	67.46
25/50*	2.400	2.586	3.075	3.336	2.756	60.96	65.68	78.11	84.73	70.00
28/56*	2.700	2.886	3.375	3.636	3.056	68.58	73.30	85.73	92.35	77.62
30/60	2.900	3.086	3.575	3.836	3.256	73.66	78.38	90.81	97.43	82.70
31/62*	3.000	3.186	3.675	3.936	3.356	76.20	80.92	93.35	99.97	85.24
35/70*	3.400	3.586	4.075	4.336	3.756	86.36	91.08	103.51	110.13	95.40
36/72	3.500	3.686	4.175	4.436	3.856	88.90	93.62	106.05	112.67	97.94
40/80*	3.900	4.086	4.575	4.836	4.256	99.06	103.78	116.21	122.83	108.10
43/86*	4.200	4.386	4.875	5.136	4.556	106.68	111.40	123.83	130.45	115.72
44/88*	4.300	4.486	4.975	5.236	4.656	109.22	113.94	126.37	132.99	118.26
49/98*	4.800	4.986	5.475	5.736	5.156	121.92	126.64	139.07	145.69	130.96
50/100	4.900	5.086	5.575	5.836	5.256	124.46	129.18	141.61	148.23	133.50
52/104*	5.100	5.286	5.775	6.036	5.456	129.54	134.26	146.69	153.31	138.58
55/110*	5.400	5.586	6.075	6.336	5.756	137.16	141.88	154.31	160.93	146.20
56/112*	5.500	5.686			5.856	139.70	144.42			148.74
57/114*	5.600	5.786			5.956	142.24	146.96			151.28
58/116*	5.700	5.886	'N' Mounting Only		6.056	144.78	149.50	'N' Mounting Only		153.82
59/118*	5.800	5.986			6.156	147.32	152.04			156.36
60/120	5.900	6.086			6.256	149.86	154.58			158.90

\* Consult Factory For Availability.



**.156" [3.96 mm] Contact Centers, .540" [13.72 mm] Insulator Height**  
**Male Card Edge, Dip Solder/Right Angle/Card Extender**

**SPECIFICATIONS**

- Compatible with .431" or .610" Insulator Height Card Edges
- Mates in place of .062" [1.57] PCB
- PBT or PA9T insulator
- 3 amp current rating
- 30 milli ohm maximum at rated current
- UL Flammability Rating: 94V-0

**Operating/Processing Temperature**

- E = PBT & Phosphor Bronze  
Operating Temperature: -65°C To +125°C  
Processing Temp: Wave only
- R = PPS & Phosphor Bronze  
Operating Temperature: -65°C To +150°C  
Processing Temperature: 260°C For 120 Sec. Max.
- G = PA9T & Phosphor Bronze  
Operating Temperature: -65°C To +150°C  
Processing Temperature: 260° For 20 Sec. Max.
- A = PPS & Beryllium Copper  
Operating Temperature: -65°C to +200°C  
Processing Temperature: 260°C For 120 Sec. Max.  
Overall Gold Plating Only (Plating code 'S' or 'M')

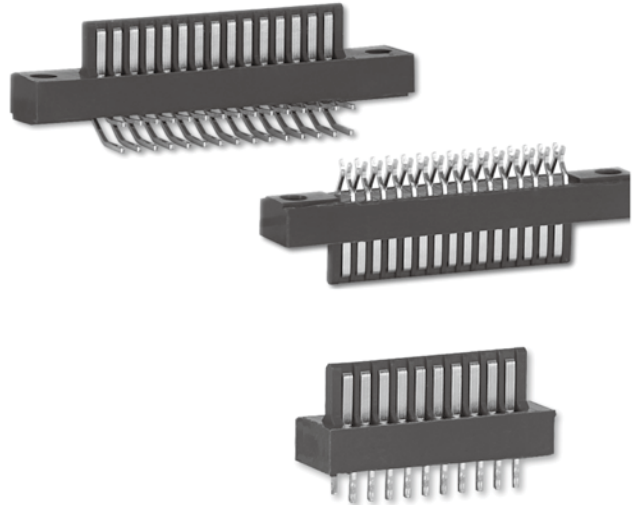

**TERMINATION TYPE**

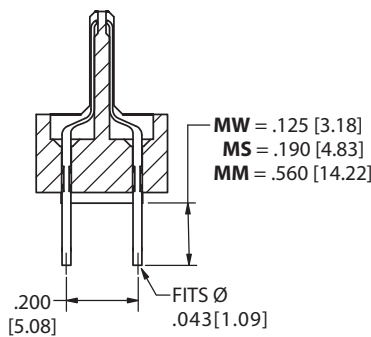

**DIP SOLDER (MW, MS)  
WIRE WRAP (MM)**

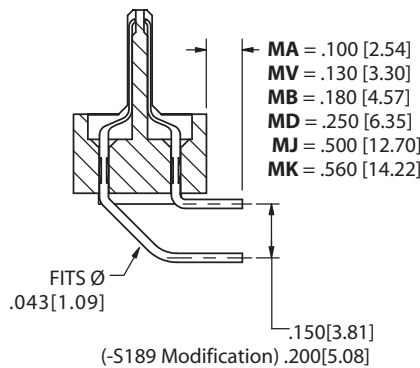

**RIGHT ANGLE  
(MA, MV, MB, MD, MJ, MK)**

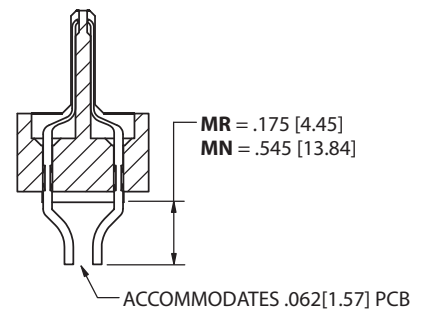

**CARD EXTENDER  
(MR, MN)**

**MOUNTING STYLE**

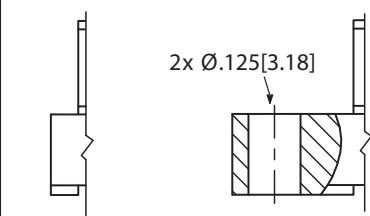

**NO MOUNTING  
(N)**

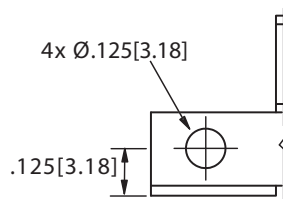

**FLUSH with CLEARANCE HOLES  
(D)**

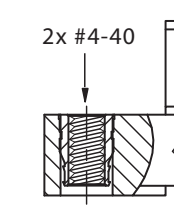

**FLUSH with THREADED INSERT  
(T)**

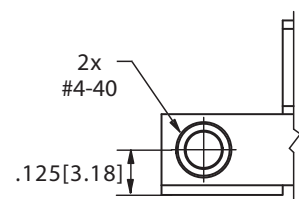

**FLUSH, with SIDE MOUNTED THREADED INSERT  
(V)**



**.156" [3.96 mm] Contact Centers, .540" [13.72 mm] Insulator Height  
Male Card Edge, Dip Solder/Right Angle/Card Extender**

**PART NUMBER OPTIONS**

**MATERIALS (Insulator/Contact)**

- E = PBT/Phosphor Bronze
- G = PA9T/Phosphor Bronze
- R = PPS/ Phosphor Bronze
- A = PPS/Beryllium Copper (Only 'S' or 'M' plating code)

Operating & Processing Temperature: see opposing page

**CONTACT FINISH - RoHS Compliant**

All platings are Lead Free and have .000050" Nickel underplate

	Contact Surface	Termination
B =	.000010" Gold	.000100" Pure Tin, Matte
C =	.000030" Gold	.000100" Pure Tin, Matte
Y =	.000030" Gold	.000005" Gold
	Contact Surface	Overall Plating
S =	.000010" Gold	.000010" Gold
M =	.000030" Gold	.000010" Gold

**CONTACT CENTERS**

M = .156" [3.96mm]

**E B M 25 M MW D - Sxxx**

**MODIFICATIONS (Consult Factory)**

- OMIT FOR STANDARD
- S189 = .200" Row Spacing (Right Angle Only)

**MOUNTING STYLE (Opposite Page)**

- N = No Mounting
- D = .250" Ears, Flush Mounting, .125" [3.18mm] Dia
- Z = .250" Ears, Flush, Side Mounting
- T = .250" Ears, Flush Mounting, #4-40 Threaded Insert
- V = Flush, Side Mounting, #4-40 Threaded Insert

**TERMINATION TYPE (Opposite Page)**

- MW, MS = Dip Solder
- MM = Wire Wrap
- MA, MV, MB = Right Angle
- MD, MJ, MK = Right Angle
- MR, MN = Card Extender

**M = Male Card Edge**

**NUMBER OF CONTACT POSITIONS**

04 thru 40 Positions (Contact Factory for Positions Not Shown)

**DIMENSIONS**

Dimensions in [ ] are in millimeters, all others are in inches.

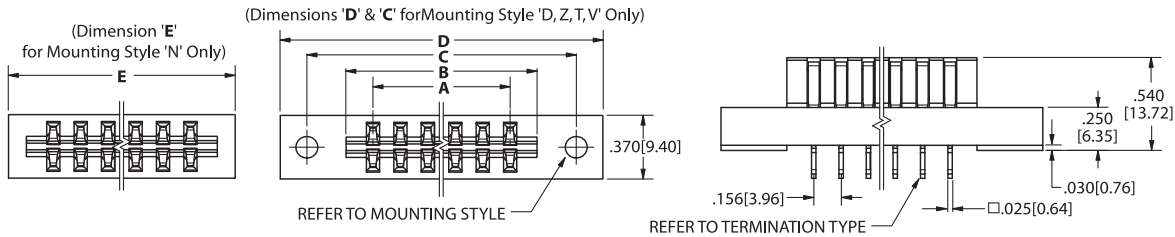

POSITIONS/ CONTACTS	INCHES					[MILLIMETERS]				
	A±.008	B±.008	C±.010	D±.020	E±.020 'N' Mtg. Only	A±0.20	B±0.20	C±0.25	D±0.51	E±0.51 'N' Mtg. Only
04/08*	0.468	0.774	1.221	1.524	0.944	11.89	19.66	31.01	38.71	23.98
05/10*	0.624	0.930	1.377	1.680	1.100	15.85	23.62	34.98	42.67	27.94
06/12	0.780	1.086	1.533	1.836	1.256	19.81	27.58	38.94	46.63	31.90
07/14*	0.936	1.242	1.689	1.992	1.412	23.77	31.55	42.90	50.60	35.86
08/16*	1.092	1.398	1.845	2.148	1.568	27.74	35.51	46.86	54.56	39.83
09/18*	1.248	1.554	2.001	2.304	1.724	31.70	39.47	50.83	58.52	43.79
10/20	1.404	1.710	2.157	2.460	1.880	35.66	43.43	54.79	62.48	47.75
11/22	1.560	1.866	2.313	2.616	2.036	39.62	47.40	58.75	66.45	51.71
12/24	1.716	2.022	2.469	2.772	2.192	43.59	51.36	62.71	70.41	55.68
13/26	1.872	2.178	2.625	2.928	2.348	47.55	55.32	66.68	74.37	59.64
14/28	2.028	2.334	2.781	3.084	2.504	51.51	59.28	70.64	78.33	63.60
15/30*	2.184	2.490	2.937	3.240	2.660	55.47	63.25	74.60	82.30	67.56
16/32*	2.340	2.646	3.093	3.396	2.816	59.44	67.21	78.56	86.26	71.53
17/34*	2.496	2.802	3.249	3.552	2.972	63.40	71.17	82.52	90.22	75.49
18/36	2.652	2.958	3.405	3.708	3.128	67.36	75.13	86.49	94.18	79.45
19/38*	2.808	3.114	3.561	3.864	3.284	71.32	79.10	90.45	98.15	83.41
20/40*	2.964	3.270	3.717	4.020	3.440	75.29	83.06	94.41	102.11	87.38
21/42*	3.120	3.426	3.873	4.176	3.596	79.25	87.02	98.37	106.07	91.34
22/44	3.276	3.582	4.029	4.332	3.752	83.21	90.98	102.34	110.03	95.30
23/46	3.432	3.738	4.185	4.488	3.908	87.17	94.95	106.30	114.00	99.26
24/48	3.588	3.894	4.341	4.644	4.064	91.14	98.91	110.26	117.96	103.23
25/50*	3.744	4.050	4.497	4.800	4.220	95.10	102.87	114.22	121.92	107.19
26/52*	3.900	4.206	4.653	4.956	4.376	99.06	106.83	118.19	125.88	111.15
27/54*	4.056	4.362	4.809	5.112	4.532	103.02	110.79	122.15	129.84	115.11
28/56	4.212	4.518	4.965	5.268	4.688	106.98	114.76	126.11	133.81	119.08
29/58*	4.368	4.674	5.121	5.424	4.844	110.95	118.72	130.07	137.77	123.04
30/60*	4.524	4.830	5.277	5.580	5.000	114.91	122.68	134.04	141.73	127.00
31/62*	4.680	4.986	5.433	5.736	5.156	118.87	126.64	138.00	145.69	130.96
32/64*	4.836	5.142	5.589	5.892	5.312	122.83	130.61	141.96	149.66	134.92
33/66*	4.992	5.298	5.745	6.048	5.468	126.80	134.57	145.92	153.62	138.89
34/68	5.148	5.454	5.901	6.204	5.624	130.76	138.53	149.89	157.58	142.85
35/70	5.304	5.610	6.057	6.360	5.780	134.72	142.49	153.85	161.54	146.81
36/72	5.460	5.766	6.213	6.516	5.936	138.68	146.46	157.81	165.51	150.77
37/74†	5.616	5.922	-----	-----	6.092	142.65	150.42	-----	-----	154.74
38/76†	5.772	6.078	-----	-----	6.248	146.61	154.38	-----	-----	158.70
39/78*†	5.928	6.234	-----	-----	6.404	150.57	158.34	-----	-----	162.66
40/80*†	6.084	6.390	-----	-----	6.560	154.53	162.31	-----	-----	166.62

† Available in 'N' Mounting Only

\* Consult Factory For Availability.



# Female Card Edge

**.100" [2.54 mm] Contact Centers, .431" [10.95 mm] Insulator Height**  
**Dip Solder/Eyelet/Right Angle for .062" [1.57] or .031" [0.79] Mating PCB**

## SPECIFICATIONS

- Accommodates .062" ± .008" [1.57 ± .20] PC board
- PBT, PPS, PA9T or PEEK insulator
- Molded-in key available
- 3 amp current rating
- 30 milli ohm maximum at rated current
- UL Flammability Rating: 94V-0

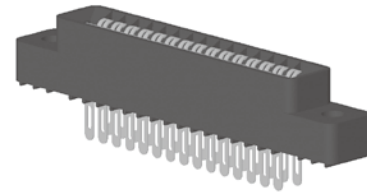

## READOUT

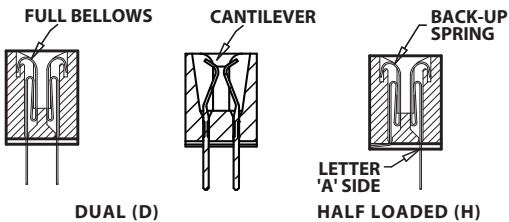

## POLARIZING KEYS (For .062" Mating PCB Only)

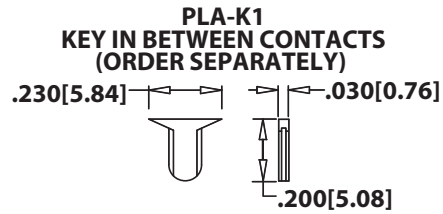

**CONSULT FACTORY FOR MOLDED-IN KEY**

## TERMINATION TYPE

FULL BELLOW	TAIL LENGTH	ROW SPACING	MIN HOLE SIZE	CANTILEVER
	RIGHT ANGLE			
	.125 [3.18] (RA)	.156 [3.96]	Ø.043 [1.09]	
	STRAIGHT			
	.200 [5.08] (RT)	.140 [3.56]	Ø.043 [1.09]	
	.440 [11.15] (RY)	.140 [3.56]	Ø.043 [1.09]	
	.185 [4.70] (RX)	.200 [5.08]	Ø.043 [1.09]	<b>FULL BELLOW</b> CARD EXTENDER ACCEPTS .062 [1.57] PCB TAIL LENGTH      MODIFICATION CODE .210 [5.33] EYELET (RE)      -S13 .185 [4.70] DIP SOLDER (RT)      -S13 .425 [10.70] DIP SOLDER (RY)      -S13
				<b>EYELET</b> ACCEPTS 3-#26 AWG 
	CRIMP TO CENTER (SX)		Ø.043 [1.09]	0.007 [0.18] THICK (RE)      .014 [0.36] THICK (TE)

## MOUNTING STYLE

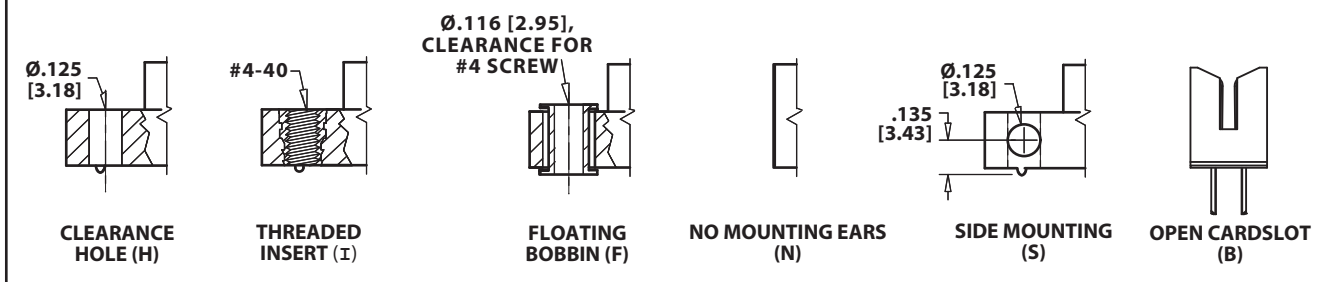



**.100" [2.54 mm] Contact Centers, .431" [10.95 mm] Insulator Height  
Dip Solder/Eyelet/Right Angle for .062" [1.57] or .031" [0.79] Mating PCB**

**PART NUMBER OPTIONS**

**MATERIALS (Insulator/Contact)**

- E = PBT/Phosphor Bronze (Standard)
- R = PPS/Phosphor Bronze
- G = PA9T/Phosphor bronze
- H = PBT/Beryllium Copper
- A = PPS/Beryllium Copper
- J = PA9T/Beryllium Copper
- \*F = PPS/Spinodal (Overall Gold Plating Only)  
Consult Factory for Special Soldering Guidelines
- \*C = PPS/Beryllium Nickel (Overall Gold Plating Only)
- \*W = PEEK/Beryllium Nickel (Overall Gold Plating Only)
- \*Consult Factory for availability.

**CONTACT FINISH - RoHS Compliant**

All platings are Lead Free and have .000050" Nickel underplate

	Contact Surface	Termination
B =	.000010" Gold	.000100" Pure Tin, Matte
C =	.000030" Gold	.000100" Pure Tin, Matte
G =	.000010" Gold	.000005" Gold
Y =	.000030" Gold	.000005" Gold
	Contact Surface	Overall Plating
S =	.000010" Gold	.000010" Gold
M =	.000030" Gold	.000010" Gold
E =	.000100" Pure Tin, Matte	.000100" Pure Tin, Matte

**CONTACT CENTERS**

C = .100" [2.54mm]

**E B C 43 D RE H - Sxxx**

**MODIFICATIONS (Consult Factory)**

OMIT FOR STANDARD

-S13 = Card Extender Accepts .062" [1.57] PCB  
(RE, RT, RY Terminations Only)

-S734 = .031" ± .008" [.79 ± .20] Thick Mating PCB

**MOUNTING STYLE (Opposite Page)**

- H = .125" [3.18mm] Clearance Holes
- N = No Mounting
- B = Open Cardslot
- S = Side Mounting
- I = Threaded Insert
- F = Floating Bobbin

**TERMINATION TYPE (Opposite Page)**

- RA = Right Angle
- RE = Eyelet (Standard)
- TE = Eyelet (Overall Plated Only)
- ET\*\*, RT = .140" [3.56mm] x .200" [5.08mm] Dip Solder
- EY\*\*, RY = .140" [3.56mm] x .440" [11.18mm] Dip Solder
- RX = .200" [5.08mm] x .185" [4.70mm] Dip Solder
- SX = .110" [2.79mm] Centered Dip Solder

**READOUT (Opposite Page)**

- D = Dual
- H = Half Loaded

**NUMBER OF CONTACT POSITIONS**

See Chart Below

\*\*ET' & 'EY' ONLY available in 'B' & 'C' Plating code

Sullins Female Card Edge

**DIMENSIONS**

Dimensions in [ ] are in millimeters, all others are in inches.

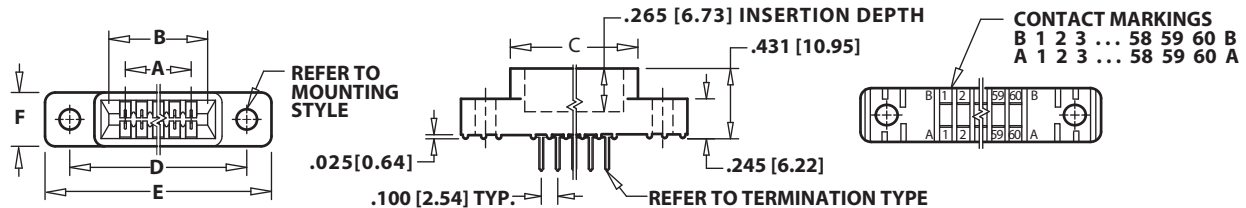

Tolerances with PPS Insulator Material may vary slightly due to shrinkage differential; Consult Factory.

POSITIONS/ CONTACTS	INCHES						[MILLIMETERS]					
	A±.008	B±.008	C±.015	D±.010	E±.020	F±.005	A±0.20	B±0.20	C±0.38	D±0.25	E±0.51	F±0.13
04/08*	0.300	0.500	0.675	0.975	1.275		7.62	12.70	17.15	24.77	32.39	
05/10	0.400	0.600	0.775	1.075	1.375		10.16	15.24	19.69	27.31	34.93	
06/12	0.500	0.700	0.875	1.175	1.475		12.70	17.78	22.23	29.85	37.47	
07/14	0.600	0.800	0.975	1.275	1.575		15.24	20.32	24.77	32.39	40.01	
08/16	0.700	0.900	1.075	1.375	1.675		17.78	22.86	27.31	34.93	42.55	
10/20	0.900	1.100	1.275	1.575	1.875		22.86	27.94	32.39	40.01	47.63	
12/24	1.100	1.300	1.475	1.775	2.075		27.94	33.02	37.47	45.09	52.71	
13/26	1.200	1.400	1.575	1.875	2.175		30.48	35.56	40.01	47.63	55.25	
15/30	1.400	1.600	1.775	2.075	2.375		35.56	40.64	45.09	52.71	60.33	
17/34	1.600	1.800	1.975	2.275	2.575		40.64	45.72	50.17	57.79	65.41	
18/36	1.700	1.900	2.075	2.375	2.675	0.330	43.18	48.26	52.71	60.33	67.95	8.38
19/38	1.800	2.000	2.175	2.475	2.775		45.72	50.80	55.25	62.87	70.49	
20/40	1.900	2.100	2.275	2.575	2.875		48.26	53.34	57.79	65.41	73.03	
22/44	2.100	2.300	2.475	2.775	3.075		53.34	58.42	62.87	70.49	78.11	
23/46*	2.200	2.400	2.575	2.875	3.175		55.88	60.96	65.41	73.03	80.65	
25/50	2.400	2.600	2.775	3.075	3.375		60.96	66.04	70.49	78.11	85.73	
26/52	2.500	2.700	2.875	3.175	3.475		63.50	68.58	73.03	80.65	88.27	
28/56	2.700	2.900	3.075	3.375	3.675		68.58	73.66	78.11	85.73	93.35	
30/60	2.900	3.100	3.275	3.575	3.875		73.66	78.74	83.19	90.81	98.43	
31/62	3.000	3.200	3.375	3.675	3.975		76.20	81.28	85.73	93.35	100.97	
35/70	3.400	3.600	3.775	4.075	4.375		86.36	91.44	95.89	103.51	111.13	
36/72	3.500	3.700	3.875	4.175	4.475		88.90	93.98	98.43	106.05	113.67	
40/80	3.900	4.100	4.275	4.575	4.875		99.06	104.14	108.59	116.21	123.83	
43/86	4.200	4.400	4.575	4.875	5.175		106.68	111.76	116.21	123.83	131.45	
44/88	4.300	4.500	4.675	4.975	5.275		109.22	114.30	118.75	126.37	133.99	
49/98	4.800	5.000	5.175	5.475	5.775	0.400	121.92	127.00	131.45	139.07	146.69	10.16
50/100	4.900	5.100	5.275	5.575	5.875		124.46	129.54	133.99	141.61	149.23	
52/104*	5.100	5.300	5.475	5.775	6.075		129.54	134.62	139.07	146.69	154.31	
60/120	5.900	6.100	6.275	6.575	6.875		149.86	154.94	159.39	167.01	174.63	
65/130	6.400	6.600	6.775	7.075	7.375		162.56	167.64	172.09	179.71	187.33	

\* Consult Factory For Availability



# Female Card Edge

**.100" [2.54 mm] Contact Centers, .431" [10.95 mm] Insulator Height**  
**Dip Solder/Eyelet/Right Angle for .093" [2.36] Mating PCB**

## SPECIFICATIONS

- Accommodates .093" ± .008" [2.36 ± .20] PC board
- PBT, PPS, PA9T, or PEEK insulator
- Molded-in key available
- 3 amp current rating
- 30 milli ohm maximum at rated current
- UL Flammability Rating: 94V-0

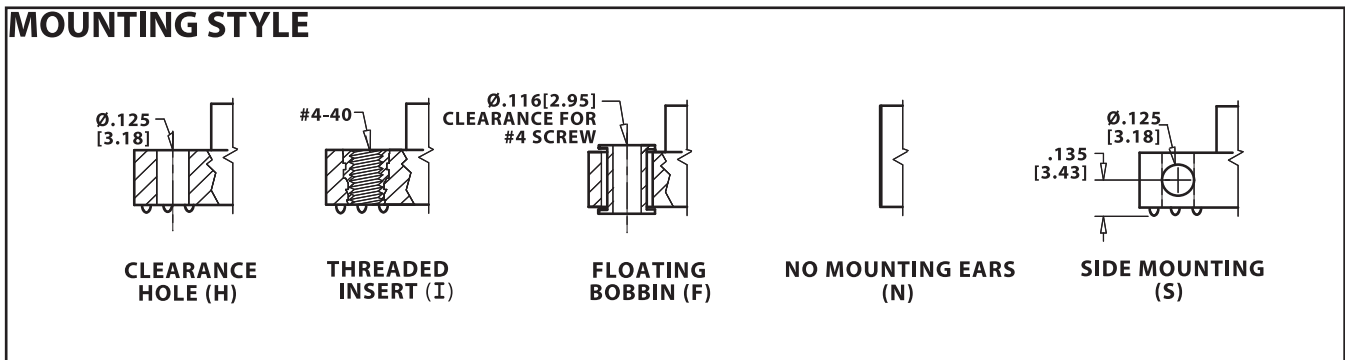
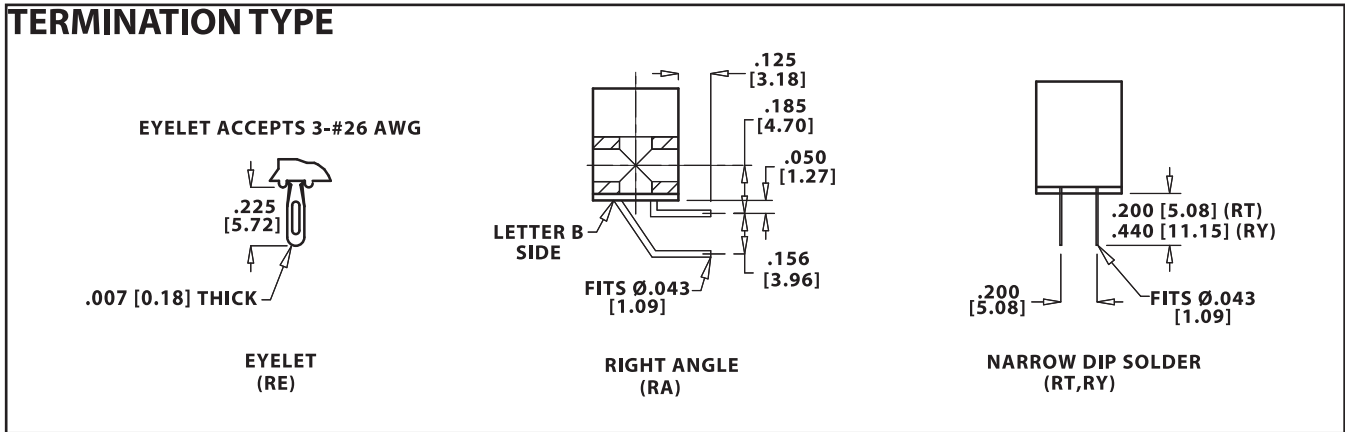
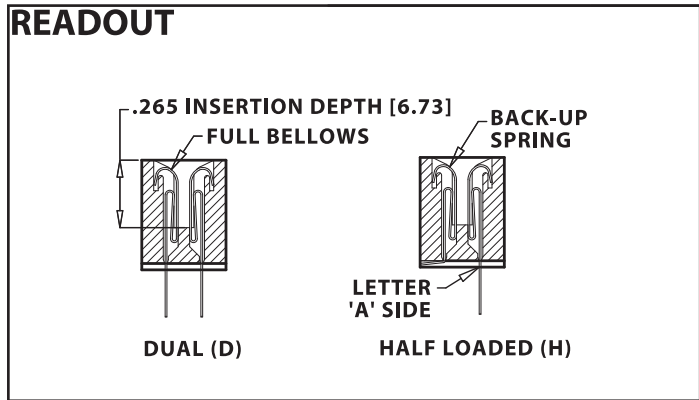
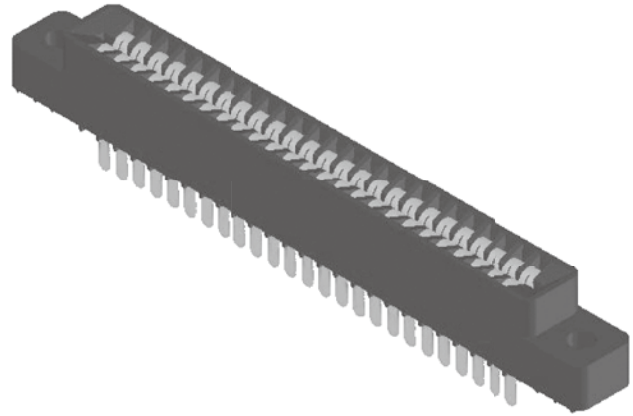



**.100" [2.54mm] Contact Centers, .431" [10.95 mm] Insulator Height  
Dip Solder/Eyelet/Right Angle for .093"[2.36] Mating PCB**

**PART NUMBER OPTIONS**

**E B C 43 D RE H -S93**

**MATERIALS (Insulator/Contact)**  
 E = PBT/Phosphor Bronze (Standard)  
 R = PPS/Phosphor Bronze  
 G = PA9T/Phosphor bronze  
 H = PBT/Beryllium Copper  
 A = PPS/Beryllium Copper  
 J = PA9T/Beryllium Copper  
 \*F = PPS/Spinodal (Overall Gold Plating Only)  
 Consult Factory for Special Soldering Guidelines  
 \*C = PPS/Beryllium Nickel (Overall Gold Plating Only)  
 \*W = PEEK/Beryllium Nickel (Overall Gold Plating Only)  
 \*Consult Factory for availability.

**CONTACT FINISH - RoHS Compliant**  
**All platings are Lead Free and have .000050" Nickel underplate**

	Contact Surface	Termination
B =	.000010" Gold	.000100" Pure Tin, Matte
C =	.000030" Gold	.000100" Pure Tin, Matte
G =	.000010" Gold	.000005" Gold
Y =	.000030" Gold	.000005" Gold
	Contact Surface	Overall Plating
S =	.000010" Gold	.000010" Gold
M =	.000030" Gold	.000010" Gold
E =	.000100" Pure Tin, Matte	.000100" Pure Tin, Matte

**MODIFICATION (CONSULT FACTORY)**  
 -S93 = .093" ± .008" [2.36 ± .20] Thick PCB

**MOUNTING STYLE (Opposite Page)**  
 H = .125" [3.18mm] Clearance Holes  
 N = No Mounting  
 S = Side Mounting  
 I = Threaded Insert  
 F = Floating Bobbin

**TERMINATION TYPE (Opposite Page)**  
 RA = Right Angle  
 RE = Eyelet  
 RT = .200" [5.08mm] x .200" [5.08mm] Dip Solder  
 RY = .200" [5.08mm] x .440" [11.18mm] Dip Solder

**READOUT (Opposite Page)**  
 D = Dual  
 H = Half Loaded

**NUMBER OF CONTACT POSITIONS**  
 See Chart Below

**CONTACT CENTERS**  
 C = .100" [2.54mm]

Sullins Female Card Edge

**DIMENSIONS**

Dimensions in [ ] are in millimeters, all others are in inches.

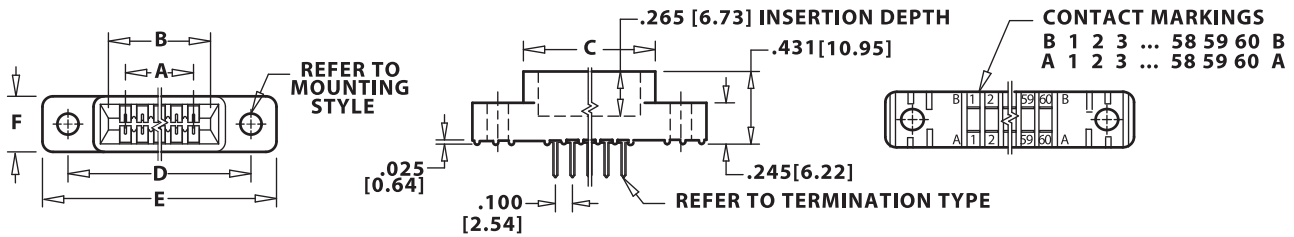

Tolerances with PPS Insulator Material may vary slightly due to shrinkage differential; Consult Factory.

POSITIONS/ CONTACTS	INCHES					F±.005	[MILLIMETERS]					
	A±.008	B±.008	C±.015	D±.010	E±.020		A±.20	B±.20	C±.38	D±.25	E±.51	F±.13
04/08*	0.300	0.500	0.675	0.975	1.275	0.330	7.62	12.70	17.15	24.77	32.39	8.38
05/10	0.400	0.600	0.775	1.075	1.375		10.16	15.24	19.69	27.31	34.93	
06/12	0.500	0.700	0.875	1.175	1.475		12.70	17.78	22.23	29.85	37.47	
07/14	0.600	0.800	0.975	1.275	1.575		15.24	20.32	24.77	32.39	40.01	
08/16	0.700	0.900	1.075	1.375	1.675		17.78	22.86	27.31	34.93	42.55	
10/20	0.900	1.100	1.275	1.575	1.875		22.86	27.94	32.39	40.01	47.63	
12/24	1.100	1.300	1.475	1.775	2.075		27.94	33.02	37.47	45.09	52.71	
13/26	1.200	1.400	1.575	1.875	2.175		30.48	35.56	40.01	47.63	55.25	
15/30	1.400	1.600	1.775	2.075	2.375		35.56	40.64	45.09	52.71	60.33	
17/34	1.600	1.800	1.975	2.275	2.575		40.64	45.72	50.17	57.79	65.41	
18/36	1.700	1.900	2.075	2.375	2.675		43.18	48.26	52.71	60.33	67.95	
19/38	1.800	2.000	2.175	2.475	2.775		45.72	50.80	55.25	62.87	70.49	
20/40	1.900	2.100	2.275	2.575	2.875		48.26	53.34	57.79	65.41	73.03	
22/44	2.100	2.300	2.475	2.775	3.075		53.34	58.42	62.87	70.49	78.11	
23/46*	2.200	2.400	2.575	2.875	3.175		55.88	60.96	65.41	73.03	80.65	
25/50	2.400	2.600	2.775	3.075	3.375		60.96	66.04	70.49	78.11	85.73	
26/52	2.500	2.700	2.875	3.175	3.475		63.50	68.58	73.03	80.65	88.27	
28/56	2.700	2.900	3.075	3.375	3.675		68.58	73.66	78.11	85.73	93.35	
30/60	2.900	3.100	3.275	3.575	3.875		73.66	78.74	83.19	90.81	98.43	
31/62	3.000	3.200	3.375	3.675	3.975		76.20	81.28	85.73	93.35	100.97	
35/70	3.400	3.600	3.775	4.075	4.375		86.36	91.44	95.89	103.51	111.13	
36/72	3.500	3.700	3.875	4.175	4.475		88.90	93.98	98.43	106.05	113.67	
40/80	3.900	4.100	4.275	4.575	4.875		99.06	104.14	108.59	116.21	123.83	
43/86	4.200	4.400	4.575	4.875	5.175	106.68	111.76	116.21	123.83	131.45		
44/88	4.300	4.500	4.675	4.975	5.275	109.22	114.30	118.75	126.37	133.99		
49/98	4.800	5.000	5.175	5.475	5.775	121.92	127.00	131.45	139.07	146.69		
50/100	4.900	5.100	5.275	5.575	5.875	124.46	129.54	133.99	141.61	149.23		
52/104*	5.100	5.300	5.475	5.775	6.075	129.54	134.62	139.07	146.69	154.31		
60/120	5.900	6.100	6.275	6.575	6.875	149.86	154.94	159.39	167.01	174.63		
65/125	6.400	6.600	6.775	7.075	7.375	162.56	167.64	172.09	179.71	187.33		

\* Consult Factory For Availability



# Female Card Edge

**.100" [2.54 mm] Contact Centers, .610" [15.49 mm] Insulator Height**  
**Dip Solder/Wire Wrap/Right Angle/Card Extender**

## SPECIFICATIONS

- Accommodates .062" ± .008" [1.57 ± .20] PC board (For .093" ± .008" [2.36 ± .20] PCB see page 52-53, 54-55; for .125" ± .008" [3.18 ± .20] PCB see page 50-51)
- PBT, PPS or PA9T insulator
- Molded-in key available
- 3 amp current rating
- 30 milli ohm maximum at rated current
- UL Flammability Rating: 94V-0

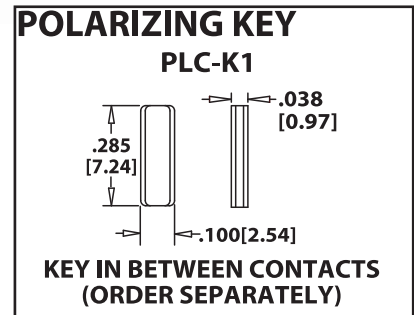
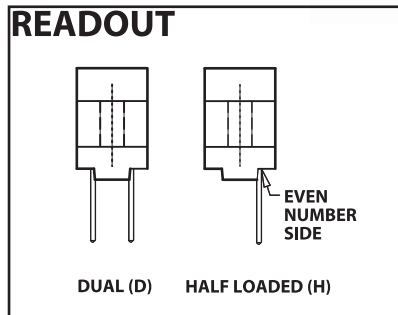
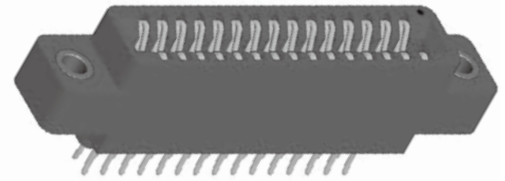

## TERMINATION TYPE

HAIRPIN BELLOWS	TERMINATION TYPE	POST CROSS SECTION K	POST LENGTH L .025 [.64]	FITS MIN. HOLE SIZE
CW	DIP SOLDER	.015 x .025 [.38 x .64]	.125 [3.18]	.035 [0.89]
CT	DIP SOLDER	.015 x .025 [.38 x .64]	.170 [4.32]	.035 [0.89]
CS	DIP SOLDER	.025 [.64] SQUARE	.160 [4.06]	.040 [1.02]
CM	WIRE WRAP	.025 [.64] SQUARE	.560 [14.20]	.040 [1.02]
CA	RIGHT ANGLE	.025 [.64] SQUARE	.100 [2.54]	.043 [1.09]
CB	RIGHT ANGLE	.025 [.64] SQUARE	.180 [4.57]	.043 [1.09]
CC	RIGHT ANGLE	.025 [.64] SQUARE	.250 [6.35]	.043 [1.09]

LOOP BELLOWS	TERMINATION TYPE	POST CROSS SECTION K	POST LENGTH L .025 [.64]	FITS MIN. HOLE SIZE
TK,CK	DIP SOLDER	.025 [0.64] ROUND	.190 [4.83]	.033 [0.84]
RS	DIP SOLDER	.025 [.64] SQUARE	.190 [4.83]	.040 [1.02]
RM	WIRE WRAP	.025 [.64] SQUARE	.560 [14.20]	.040 [1.02]
TA	RIGHT ANGLE	.025 [.64] SQUARE	.100 [2.54]	.043 [1.09]
TB	RIGHT ANGLE	.025 [.64] SQUARE	.180 [4.57]	.043 [1.09]
TM	RIGHT ANGLE	.025 [.64] SQUARE	.250 [6.35]	.043 [1.09]

CANTILEVER	TERMINATION TYPE	POST CROSS SECTION K	POST LENGTH L .025 [.64]	FITS MIN. HOLE SIZE
KS	DIP SOLDER	.025 [.64] SQUARE	.190 [4.83]	.040 [1.02]
KD	DIP SOLDER	.025 [.64] SQUARE	.160 [4.06]	.043 [1.09]
KM	WIRE WRAP	.025 [.64] SQUARE	.560 [14.20]	.040 [1.02]
*KA	RIGHT ANGLE	.025 [.64] SQUARE	.100 [2.54]	.043 [1.09]
*KE	RIGHT ANGLE	.025 [.64] SQUARE	.180 [4.57]	.043 [1.09]
*KU	RIGHT ANGLE	.025 [.64] SQUARE	.250 [6.35]	.043 [1.09]
*KJ	RIGHT ANGLE	.025 [.64] SQUARE	.500 [12.70]	.043 [1.09]
*KR	CARD EXTENDER	.025 [.64] SQUARE	.235 [5.97]	N/A
*KN	CARD EXTENDER	.025 [.64] SQUARE	.605 [15.37]	N/A

\* KA, KE, KJ, KR, KN have no standoffs, unless requested.

### HAIRPIN BELLOWS

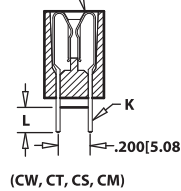

### RIGHT ANGLE

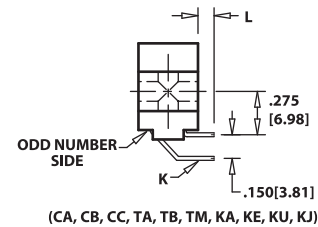

### LOOP BELLOWS

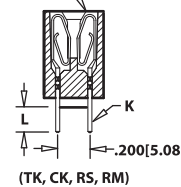

### HAIRPIN or LOOP CARD EXTENDER

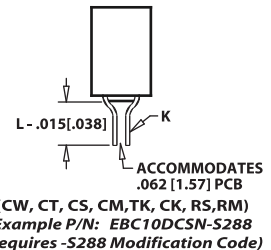

### CANTILEVER

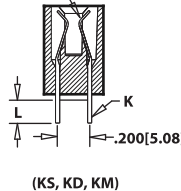

### CANTILEVER CARD EXTENDER

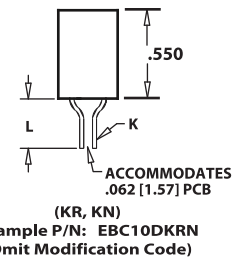

## MOUNTING STYLE

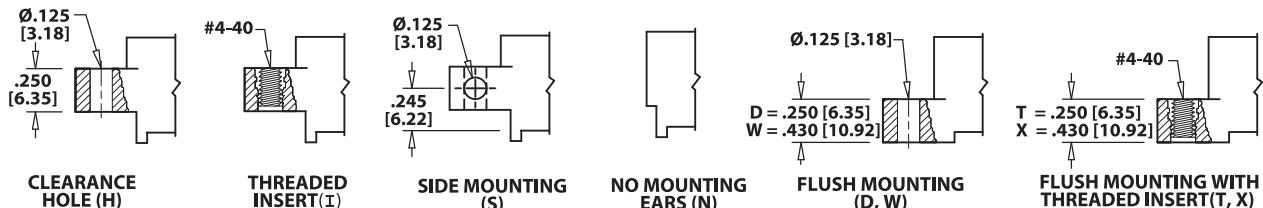



**.100" [2.54 mm] Contact Centers, .610" [15.49 mm] Insulator Height  
Dip Solder/Wire Wrap/Right Angle/Card Extender**

**PART NUMBER OPTIONS**

**MATERIALS (Insulator/Contact)**

- E = PBT/Phosphor Bronze (Standard)
- R = PPS/Phosphor Bronze
- G = PA9T/Phosphor Bronze
- H = PBT/Beryllium Copper
- A = PPS/Beryllium Copper
- J = PA9T/Beryllium Copper
- (Consult Factory for Other Materials)

**CONTACT FINISH - RoHS Compliant**  
All platings are Lead Free and have .000050" Nickel underplate

Contact Surface	Termination
B = .000010" Gold	.000100" Pure Tin, Matte
C = .000030" Gold	.000100" Pure Tin, Matte
G = .000010" Gold	.000005" Gold
Y = .000030" Gold	.000005" Gold

Contact Surface	Overall Plating
S = .000010" Gold	.000010" Gold
M = .000030" Gold	.000010" Gold
E = .000100" Pure Tin, Matte	.000100" Pure Tin, Matte

**CONTACT CENTERS**  
C = .100" [2.54mm]

**NUMBER OF CONTACT POSITIONS**  
See Chart Below

**READOUT (Opposite Page)**

- D = Dual
- H = Half Loaded

**MODIFICATION CODE (Consult Factory)**  
OMIT FORT STANDARD

- S189 = .200" [5.08mm] Row to Row on Right Angle
- S288\* = Card Extender Accepts .062" [1.57] PCB
- \* Not Required on KR or KN Terminations

**MOUNTING STYLE (Opposite Page)**

- H = Clearance Holes
- I = Threaded Inserts
- S = Side Mounting
- N = No Mounting
- D, W = Flush Mounting
- T, X = Flush Mounting With Threaded Inserts

**TERMINATION TYPE (Opposite Page)**

**Hairpin Bellows - Available with B or C plating and Phosphor Bronze Only**

- CS = .025" [.64mm] Square Dip Solder
- CM = .025 [.64mm] Square Wire Wrap
- CA, CB, CC = .025" [.64mm] Square Right Angle
- CW, CT = .015" x .025" [.38 x .64] Dip Solder

**Loop Bellows**

- RS = .025" [.64mm] Square Dip Solder
- CK, TK = .025" [.64mm] Round Dip Solder
- RM = .025" [.64mm] Square Wire Wrap
- TA, TB, TM = .025" [.64mm] Square Right Angle

**Cantilever Bellows - Available in Y, B, or C plating Only**  
Not Available with R or A Materials

- KS, KD = .025" [.64mm] Square Dip Solder
- KM = .025 [.64mm] Square Wire Wrap
- KA, KE, KU, KJ = .025" [.64mm] Square Right Angle
- KR, KN = .025" [.64mm] Square Card Extender

Sullins Female Card Edge

**DIMENSIONS**

Dimensions in [ ] are in millimeters, all others are in inches.

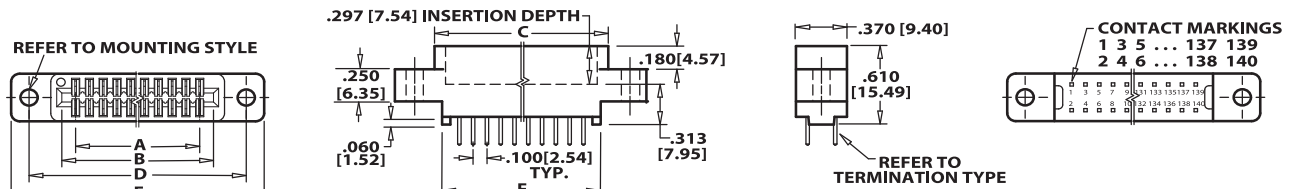

Tolerances with PPS Insulator Material may vary slightly due to shrinkage differential; Consult Factory.

POSITIONS/ CONTACTS	INCHES						[MILLIMETERS]					
	A±.008	B±.008	C±.015	D±.010	E±.020	F±.015	A±0.20	B±0.20	C±0.38	D±0.25	E±0.51	F±0.38
06/12	0.500	0.700	0.860	1.175	1.435	0.750	12.70	17.78	21.84	29.85	36.45	19.05
07/14*	0.600	0.800	0.960	1.275	1.535	0.850	15.24	20.32	24.38	32.39	38.99	21.59
08/16	0.700	0.900	1.060	1.375	1.635	0.950	17.78	22.86	26.92	34.93	41.53	24.13
10/20	0.900	1.100	1.260	1.575	1.835	1.150	22.86	27.94	32.00	40.01	46.61	29.21
12/24	1.100	1.300	1.460	1.775	2.035	1.350	27.94	33.02	37.08	45.09	51.69	34.29
13/26	1.200	1.400	1.560	1.875	2.135	1.450	30.48	35.56	39.62	47.63	54.23	36.83
15/30	1.400	1.600	1.760	2.075	2.335	1.650	35.56	40.64	44.70	52.71	59.31	41.91
17/34	1.600	1.800	1.960	2.275	2.535	1.850	40.64	45.72	49.78	57.79	64.39	46.99
18/36	1.700	1.900	2.060	2.375	2.635	1.950	43.18	48.26	52.32	60.33	66.93	49.53
20/40	1.900	2.100	2.260	2.575	2.835	2.150	48.26	53.34	57.40	65.41	72.01	54.61
22/44	2.100	2.300	2.460	2.775	3.035	2.350	53.34	58.42	62.48	70.49	77.09	59.69
24/48	2.300	2.500	2.660	2.975	3.235	2.550	58.42	63.50	67.56	75.57	82.17	64.77
25/50	2.400	2.600	2.760	3.075	3.335	2.650	60.96	66.04	70.10	78.11	84.71	67.31
28/56	2.700	2.900	3.060	3.375	3.635	2.950	68.58	73.66	77.72	85.73	92.33	74.93
30/60	2.900	3.100	3.260	3.575	3.835	3.150	73.66	78.74	82.80	90.81	97.41	80.01
31/62	3.000	3.200	3.360	3.675	3.935	3.250	76.20	81.28	85.34	93.35	99.95	82.55
35/70	3.400	3.600	3.760	4.075	4.335	3.650	86.36	91.44	95.50	103.51	110.11	92.71
36/72	3.500	3.700	3.860	4.175	4.435	3.750	88.90	93.98	98.04	106.05	112.65	95.25
40/80	3.900	4.100	4.260	4.575	4.835	4.150	99.06	104.14	108.20	116.21	122.81	105.41
43/86	4.200	4.400	4.560	4.875	5.135	4.450	106.68	111.76	115.82	123.83	130.43	113.03
44/88	4.300	4.500	4.660	4.975	5.235	4.550	109.22	114.30	118.36	126.37	132.97	115.57
49/98*	4.800	5.000	5.160	5.475	5.735	5.050	121.92	127.00	131.06	139.07	145.67	128.27
50/100	4.900	5.100	5.260	5.575	5.835	5.150	124.46	129.54	133.60	141.61	148.21	130.81
55/110	5.400	5.600	5.760	6.075	6.335	5.650	137.16	142.24	146.30	154.31	160.91	143.51
60/120	5.900	6.100	6.260	6.575	6.835	6.150	149.86	154.94	159.00	167.01	173.61	156.21
61/122	6.000	6.200	6.360	6.675	6.935	6.250	152.40	157.48	161.54	169.55	176.15	158.75
65/130	6.400	6.600	6.760	7.075	7.335	6.650	162.56	167.64	171.70	179.71	186.31	168.91
70/140	6.900	7.100	7.260	7.575	7.835	7.150	175.26	180.34	184.40	192.41	199.01	181.61
80/160*	7.900	8.100	8.260	8.575	8.835	8.150	200.66	205.74	209.80	217.81	224.41	207.01
90/180*	8.900	9.100	9.260	9.575	9.835	9.150	226.06	231.14	235.20	243.21	249.81	232.41
100/200*	9.900	10.100	10.260	10.575	10.835	10.150	251.46	256.54	260.60	268.61	275.21	257.81

\* Consult factory for availability.



# Female Card Edge

**.100" [2.54 mm] Contact Centers, .610" [15.49 mm] Profile, .400" [10.16 mm] Wide Body Dip Solder/Wire Wrap/Right Angle/Card Extender for .062" or .093" Mating PCB**

## SPECIFICATIONS

- Accommodates .062" ± .008 [1.57 ± .20] or .093" ± .008" [2.36 ± .20] PC board
- PPS, PBT or PA9T insulator
- 3 amp current rating
- 30 milli ohm maximum at rated current
- UL Flammability Rating: 94V-0

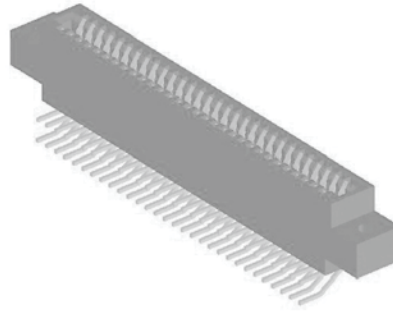

## READOUT

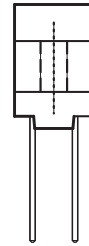

DUAL (D)

## TERMINATION TYPE

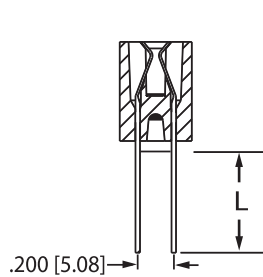

DIP SOLDER/WIRE WRAP  
(KS, KD, KM)

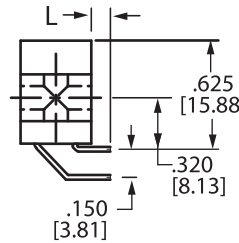

RIGHT ANGLE  
(KA, KE, KU, KJ)

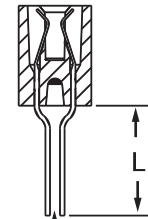

CARD EXTENDER  
(KR, KN)

TERMINATION	TERMINATION TYPE	POST LENGTH L ±.025 [.64]	FITS MIN. HOLE SIZE	STANDOFF
<b>KD</b>	DIP SOLDER	.160 [4.06]	.043 [1.09]	YES
<b>KS</b>	DIP SOLDER	.190 [4.83]	.040 [1.02]	YES
<b>KM</b>	WIRE WRAP	.560 [14.22]	.040 [1.02]	YES
<b>KA</b>	RIGHT ANGLE	.100 [2.54]	.043 [1.09]	NO
<b>KE</b>	RIGHT ANGLE	.180 [4.57]	.043 [1.09]	NO
<b>KU</b>	RIGHT ANGLE	.250 [6.35]	.043 [1.09]	NO
<b>KJ</b>	RIGHT ANGLE	.500 [12.70]	.043 [1.09]	NO
<b>KR</b>	CARD EXTENDER	.235 [5.97]	N/A	NO
<b>KN</b>	CARD EXTENDER	.605 [15.37]	N/A	NO

## MOUNTING STYLE

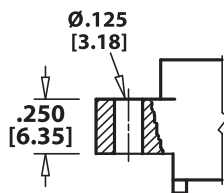

CLEARANCE HOLE (H)

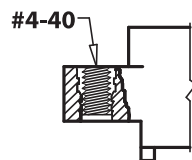

THREADED INSERT (I)

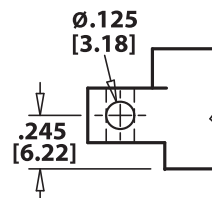

SIDE MOUNTING (S)



NO MOUNTING EARS (N)



**.100" [2.54 mm] Contact Centers, .610" [15.49 mm] Profile, .400" [10.16 mm] Wide Body  
Dip Solder/Wire Wrap/Right Angle/Card Extender for .062" or .093" Mating PCB**

**PART NUMBER OPTIONS**

**MATERIALS (Insulator /Contact)** ————— A B C 30 D KE H - S1191

E = PBT/Phosphor Bronze  
R = PPS/Phosphor Bronze  
G = PA9T/Phosphor Bronze  
H = PBT/Beryllium Copper  
A = PPS/Beryllium Copper  
J = PA9T/Beryllium Copper  
(Consult Factory for Other Materials)

**CONTACT FINISH - RoHS Compliant**

**All platings are Lead Free and have .000050" Nickel underplate**

Contact Surface	Termination
B = .000010" Gold	.000100" Pure Tin, Matte
C = .000030" Gold	.000100" Pure Tin, Matte
Y = .000030" Gold	.000005" Gold

**CONTACT CENTERS**  
C = .100" [2.54mm]

**NUMBER OF CONTACT POSITIONS**  
See Chart Below

**MODIFICATION CODE (Consult Factory)**  
-S1243 = For .062" ± .008 [1.57" ± .20] PCB  
-S1191 = For .093" ± .008" [2.36 ± .20] PCB

**MOUNTING STYLE (Opposite Page)**  
H = Clearance Holes  
I = Threaded Inserts  
S = Side Mounting  
N = No Mounting

**TERMINATION TYPE (Opposite Page)**  
KD, KS = .025" [.64] Square Dip Solder  
KM = .025" [.64] Square Wire Wrap  
KA, KE, = .025" [.64mm] Square Right Angle  
KU, KJ = .025" [.64mm] Square Card Extender

**READOUT (Opposite Page)**  
D = Dual

**DIMENSIONS**

Dimensions in [ ] are in millimeters, all others are in inches.

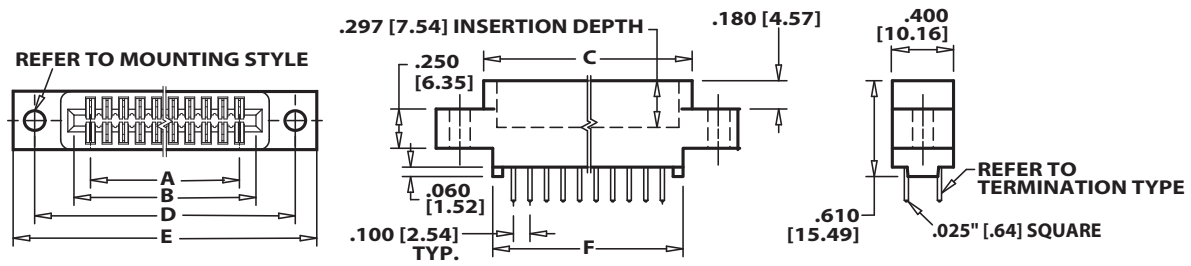

Tolerances with PPS Insulator Material may vary slightly due to shrinkage differential; Consult Factory.

POSITIONS/ CONTACTS	INCHES						[MILLIMETERS]					
	A±.008	B±.012	C±.015	D±.010	E±.020	F±.015	A±0.20	B±0.30	C±0.38	D±0.25	E±0.51	F±0.38
06/12*	0.500	0.700	0.860	1.175	1.435	0.742	12.70	17.78	21.84	29.85	36.45	18.85
07/14*	0.600	0.800	0.960	1.275	1.535	0.842	15.24	20.32	24.38	32.39	38.99	21.39
08/16*	0.700	0.900	1.060	1.375	1.635	0.942	17.78	22.86	26.92	34.93	41.53	23.93
10/20*	0.900	1.100	1.260	1.575	1.835	1.142	22.86	27.94	32.00	40.01	46.61	29.01
12/24	1.100	1.300	1.460	1.775	2.035	1.342	27.94	33.02	37.08	45.09	51.69	34.09
13/26*	1.200	1.400	1.560	1.875	2.135	1.442	30.48	35.56	39.62	47.63	54.23	36.63
15/30	1.400	1.600	1.760	2.075	2.335	1.642	35.56	40.64	44.70	52.71	59.31	41.71
17/34*	1.600	1.800	1.960	2.275	2.535	1.842	40.64	45.72	49.78	57.79	64.39	46.79
18/36*	1.700	1.900	2.060	2.375	2.635	1.942	43.18	48.26	52.32	60.33	66.93	49.33
20/40	1.900	2.100	2.260	2.575	2.835	2.142	48.26	53.34	57.40	65.41	72.01	54.41
22/44	2.100	2.300	2.460	2.775	3.035	2.342	53.34	58.42	62.48	70.49	77.09	59.49
24/48*	2.300	2.500	2.660	2.975	3.235	2.542	58.42	63.50	67.56	75.57	82.17	64.57
25/50*	2.400	2.600	2.760	3.075	3.335	2.642	60.96	66.04	70.10	78.11	84.71	67.11
28/56*	2.700	2.900	3.060	3.375	3.635	2.942	68.58	73.66	77.72	85.73	92.33	74.73
30/60	2.900	3.100	3.260	3.575	3.835	3.142	73.66	78.74	82.80	90.81	97.41	79.81
31/62*	3.000	3.200	3.360	3.675	3.935	3.242	76.20	81.28	85.34	93.35	99.95	82.35
35/70*	3.400	3.600	3.760	4.075	4.335	3.642	86.36	91.44	95.50	103.51	110.11	92.51
36/72*	3.500	3.700	3.860	4.175	4.435	3.742	88.90	93.98	98.04	106.05	112.65	95.05
40/80*	3.900	4.100	4.260	4.575	4.835	4.142	99.06	104.14	108.20	116.21	122.81	105.21
43/86	4.200	4.400	4.560	4.875	5.135	4.442	106.68	111.76	115.82	123.83	130.43	112.83
44/88*	4.300	4.500	4.660	4.975	5.235	4.542	109.22	114.30	118.36	126.37	132.97	115.37
49/98*	4.800	5.000	5.160	5.475	5.735	5.042	121.92	127.00	131.06	139.07	145.67	128.07
50/100	4.900	5.100	5.260	5.575	5.835	5.142	124.46	129.54	133.60	141.61	148.21	130.61
55/110	5.400	5.600	5.760	6.075	6.335	5.642	137.16	142.24	146.30	154.31	160.91	143.31
60/120*	5.900	6.100	6.260	6.575	6.835	6.142	149.86	154.94	159.00	167.01	173.61	156.01
61/122*	6.000	6.200	6.360	6.675	6.935	6.242	152.40	157.48	161.54	169.55	176.15	158.55
65/130*	6.400	6.600	6.760	7.075	7.335	6.642	162.56	167.64	171.70	179.71	186.31	168.71
70/140	6.900	7.100	7.260	7.575	7.835	7.142	175.26	180.34	184.40	192.41	199.01	181.41

\* Consult Factory For Availability.



**.100" [2.54 mm] Contact Centers, .610" [15.49 mm] Profile, .470" [11.94 mm] Wide Body Dip Solder/Wire Wrap/Right Angle/Card Extender for .093" or .125" Mating PCB**

**SPECIFICATIONS**

- Accommodates .093" ± .008" [2.36 ± .20] or .125" ± .008" [3.18 ± .20] mating PC board (Consult factory for .031" ± .008" [.79 ± .20] boards)
- PBT, PPS or PA9T insulator
- Molded-in key available
- 3 amp current rating
- 30 milli ohm maximum at rated current
- UL Flammability Rating: 94V-0

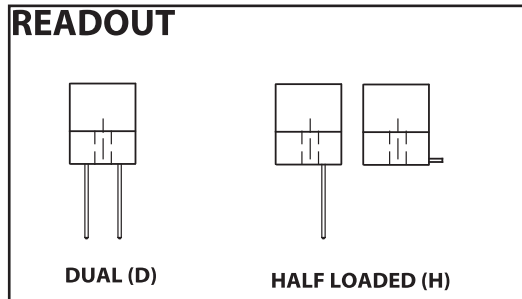
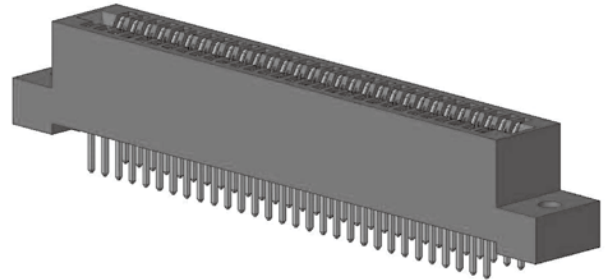

**TERMINATION TYPE**

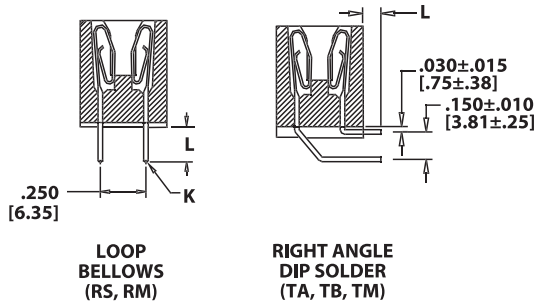

TERMINATION TYPE	POST CROSS SECTION (K)	POST LENGTH L ±.025[.64]	FITS MIN. HOLE SIZE
<b>RS</b> Dip Solder	.025[.64] SQUARE	.190 [4.83]	.040 [1.02]
<b>RM</b> Wire Wrap	.025[.64] SQUARE	.560 [14.20]	.040 [1.02]
<b>TA</b> Right Angle	.025[.64] SQUARE	.100 [2.54]	.043 [1.09]
<b>TB</b> Right Angle	.025[.64] SQUARE	.180 [4.57]	.043 [1.09]
<b>TM</b> Right Angle	.025[.64] SQUARE	.250 [6.35]	.043 [1.09]

**PCB LAYOUT**

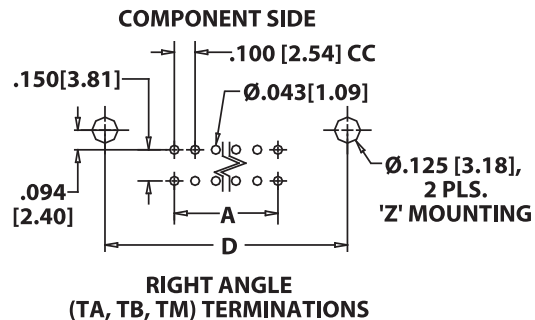
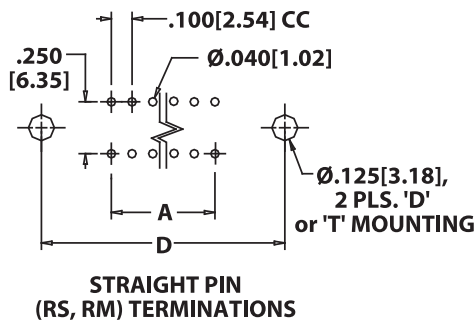

**MOUNTING STYLE**

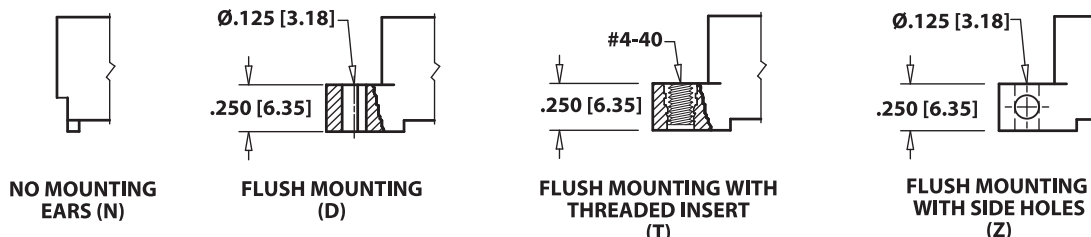



**.100" [2.54 mm] Contact Centers, .610" [15.49 mm] Profile, .470" [11.94 mm] Wide Body  
Dip Solder/Wire Wrap/Right Angle/Card Extender for .093" or .125" Mating PCB**

**PART NUMBER OPTIONS**

**MATERIALS (Insulator /Contact)**

- E = PBT/Phosphor Bronze
- R = PPS/Phosphor Bronze
- G = PA9T/Phosphor Bronze
- H = PBT/Beryllium Copper
- A = PPS/Beryllium Copper
- J = PA9T/Beryllium Copper
- (Consult Factory for Other Materials)

**CONTACT FINISH - RoHS Compliant**

All platings are Lead Free and have .000050" Nickel underplate

	<b>Contact Surface</b>	<b>Termination</b>
B =	.000010" Gold	.000100" Pure Tin, Matte
C =	.000030" Gold	.000100" Pure Tin, Matte
G =	.000010" Gold	.000005" Gold
Y =	.000030" Gold	.000005" Gold
	<b>Contact Surface</b>	<b>Overall Plating</b>
S =	.000010" Gold	.000010" Gold
M =	.000030" Gold	.000010" Gold
E =	.000100" Pure Tin, Matte	.000100" Pure Tin, Matte

**E B C 70 D RM D - S273**

**MODIFICATION CODE (Consult Factory)**  
 -S273 = FOR .093" ± .008" [ 2.36 ± .20]  
 THICK MATING PCB  
 -S664 = FOR .125" ± .008" [ 3.18 ± .20]  
 THICK MATING PCB

**MOUNTING STYLE (Opposite Page)**  
 N = No Mounting  
 D = Flush Mounting  
 T = Flush Mounting With Threaded Inserts  
 Z = Flush Mounting With Side Holes

**TERMINATION TYPE (Opposite Page)**  
 RS = .025" [0.64mm] Square Dip Solder  
 RM = .025" [0.64mm] Square Wire Wrap  
 TA, TB, TM = .025" [0.64mm] Square Right Angle

**READOUT (Opposite Page)**  
 D = Dual  
 H = Half Loaded

**NUMBER OF CONTACT POSITIONS**  
 See Chart Below

**CONTACT CENTERS**  
 C = .100" [2.54mm]

Sullins Female Card Edge

**DIMENSIONS**

Dimensions in [ ] are in millimeters, all others are in inches.

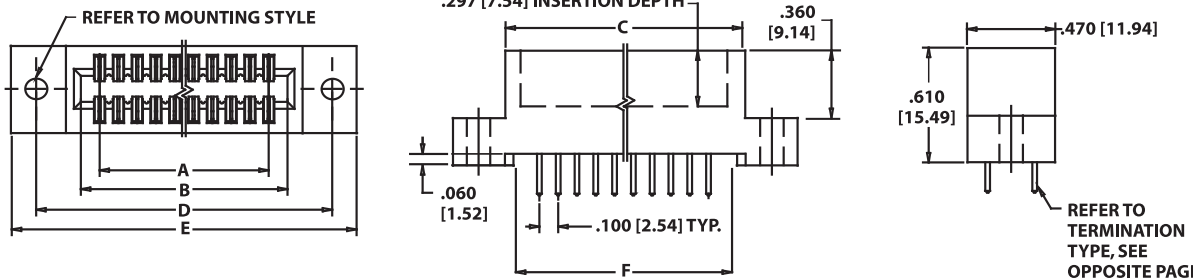

Tolerances with PPS Insulator Material may vary slightly due to shrinkage differential; Consult Factory.

POSITIONS/ CONTACTS	INCHES						[MILLIMETERS]					
	A±.008	B±.008	C±.015	D±.010	E±.020	F±.015	A±0.20	B±0.20	C±0.38	D±0.25	E±0.51	F±0.38
06/12	0.500	0.700	0.860	1.175	1.435	0.750	12.70	17.78	21.84	29.85	36.45	19.05
07/14*	0.600	0.800	0.960	1.275	1.535	0.850	15.24	20.32	24.38	32.39	38.99	21.59
08/16*	0.700	0.900	1.060	1.375	1.635	0.950	17.78	22.86	26.92	34.93	41.53	24.13
10/20	0.900	1.100	1.260	1.575	1.835	1.150	22.86	27.94	32.00	40.01	46.61	29.21
12/24	1.100	1.300	1.460	1.775	2.035	1.350	27.94	33.02	37.08	45.09	51.69	34.29
15/30*	1.400	1.600	1.760	2.075	2.335	1.650	35.56	40.64	44.70	52.71	59.31	41.91
17/34*	1.600	1.800	1.960	2.275	2.535	1.850	40.64	45.72	49.78	57.79	64.39	46.99
18/36	1.700	1.900	2.060	2.375	2.635	1.950	43.18	48.26	52.32	60.33	66.93	49.53
20/40*	1.900	2.100	2.260	2.575	2.835	2.150	48.26	53.34	57.40	65.41	72.01	54.61
22/44	2.100	2.300	2.460	2.775	3.035	2.350	53.34	58.42	62.48	70.49	77.09	59.69
24/48*	2.300	2.500	2.660	2.975	3.235	2.550	58.42	63.50	67.56	75.57	82.17	64.77
25/50*	2.400	2.600	2.760	3.075	3.335	2.650	60.96	66.04	70.10	78.11	84.71	67.31
28/56	2.700	2.900	3.060	3.375	3.635	2.950	68.58	73.66	77.72	85.73	92.33	74.93
30/60	2.900	3.100	3.260	3.575	3.835	3.150	73.66	78.74	82.80	90.81	97.41	80.01
31/62*	3.000	3.200	3.360	3.675	3.935	3.250	76.20	81.28	85.34	93.35	99.95	82.55
35/70	3.400	3.600	3.760	4.075	4.335	3.650	86.36	91.44	95.50	103.51	110.11	92.71
36/72	3.500	3.700	3.860	4.175	4.435	3.750	88.90	93.98	98.04	106.05	112.65	95.25
40/80*	3.900	4.100	4.260	4.575	4.835	4.150	99.06	104.14	108.20	116.21	122.81	105.41
43/86*	4.200	4.400	4.560	4.875	5.135	4.450	106.68	111.76	115.82	123.83	130.43	113.03
44/88*	4.300	4.500	4.660	4.975	5.235	4.550	109.22	114.30	118.36	126.37	132.97	115.57
49/98*	4.800	5.000	5.160	5.475	5.735	5.050	121.92	127.00	131.06	139.07	145.67	128.27
50/100	4.900	5.100	5.260	5.575	5.835	5.150	124.46	129.54	133.60	141.61	148.21	130.81
55/110	5.400	5.600	5.760	6.075	6.335	5.650	137.16	142.24	146.30	154.31	160.91	143.51
60/120*	5.900	6.100	6.260	6.575	6.835	6.150	149.86	154.94	159.00	167.01	173.61	156.21
61/122	6.000	6.200	6.360	6.675	6.935	6.250	152.40	157.48	161.54	169.55	176.15	158.75
65/130*	6.400	6.600	6.760	7.075	7.335	6.650	162.56	167.64	171.70	179.71	186.31	168.91
70/140	6.900	7.100	7.260	7.575	7.835	7.150	175.26	180.34	184.40	192.41	199.01	181.61

\* Consult Factory For Availability.



**.100" [2.54 mm] Contact Centers, .610" [15.49 mm] Insulator Height**  
**[ISA] Dip Solder/Wire Wrap/Right Angle**

**SPECIFICATIONS**

- Accommodates .062" ± .008" [1.57 ± .20] PCB
- PBT or PA9T insulator
- Molded-in key available
- 3 amp current rating
- 30 milli ohm maximum at rated current
- UL Flammability Rating: 94V-0

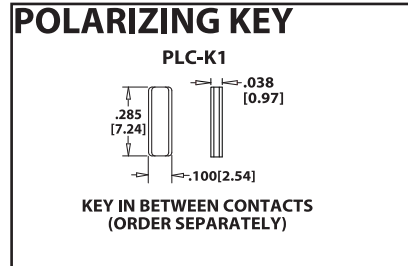
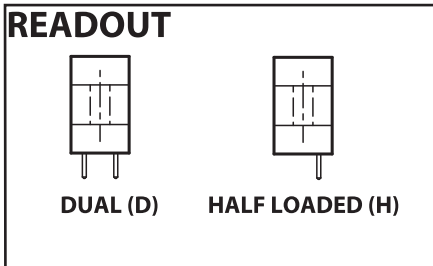
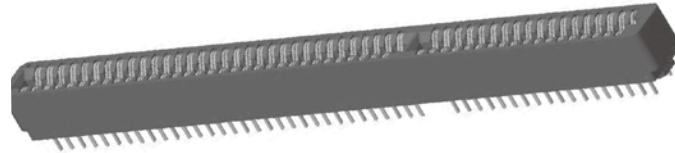

**TERMINATION TYPE**

**HAIRPIN BELLOWS**

**HAIRPIN BELLOWS (CS,CM,CW,CT)**

**LOOP BELLOWS**

**LOOP BELLOWS (TK,RS,RM)**

**RIGHT ANGLE, DIP SOLDER (CA,CB,CC,TA,TB,TM) -S605 MODIFICATION**

HAIRPIN BELLOWS	LOOP	TERMINATION TYPE	POST CROSS SECTION K	POST LENGTH L .025 [.64]	FITS MIN. HOLE SIZE
	TK, CK	DIP SOLDER	.025 [.64] ROUND	.190 [4.83]	.033 [0.84]
	RS	DIP SOLDER	.025 [.64] SQUARE	.190 [4.83]	.040 [1.02]
CM	RM	WIRE WRAP	.025 [.64] SQUARE	.560 [14.20]	.040 [1.02]
CA	TA	RIGHT ANGLE	.025 [.64] SQUARE	.100 [2.54]	.043 [1.09]
CB	TB	RIGHT ANGLE	.025 [.64] SQUARE	.180 [4.57]	.043 [1.09]
CC	TM	RIGHT ANGLE	.025 [.64] SQUARE	.250 [6.35]	.043 [1.09]
CW		DIP SOLDER	.015 X .025 [.38 X .64]	.125 [3.18]	.035 [0.76]
CT		DIP SOLDER	.015 X .025 [.38 X .64]	.170 [4.32]	.035 [0.89]
CS		DIP SOLDER	.025 [.64] SQUARE	.160 [4.06]	.040 [1.02]

**MOUNTING STYLE**

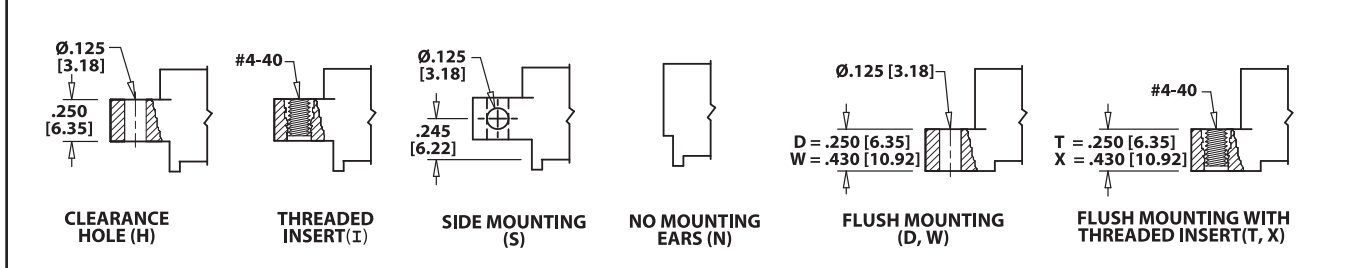



**.100" [2.54 mm] Contact Centers, .610" [15.49 mm] Insulator Height  
[ISA] Dip Solder/Wire Wrap/Right Angle**

**PART NUMBER OPTIONS**

**E B C 49 D CW N - S420**

**MATERIALS (Insulator/Contact)**  
 E = PBT/Phosphor Bronze (Standard)  
 G = PA9T/Phosphor Bronze  
 H = PBT/Beryllium Copper  
 J = PA9T/Beryllium Copper  
 (Consult Factory for Other Materials)

**CONTACT FINISH - RoHS Compliant**  
 All platings are Lead Free and have .000050" Nickel underplate

	Contact Surface	Termination
B =	.000010" Gold	.000100" Pure Tin, Matte
C =	.000030" Gold	.000100" Pure Tin, Matte
G =	.000010" Gold	.000005" Gold
Y =	.000030" Gold	.000005" Gold
	Contact Surface	Overall Plating
S =	.000010" Gold	.000010" Gold
M =	.000030" Gold	.000010" Gold
E =	.000100" Pure Tin, Matte	.000100" Pure Tin, Matte

**CONTACT CENTERS**  
 C = .100" [2.54mm]

**NUMBER OF CONTACT POSITIONS**  
 18, 31 or 49 (31/18)

**READOUT (Opposite page)**  
 D = Dual  
 H = Half Loaded

**MODIFICATION CODE (Consult Factory)**  
**ISA WITH RETENTION FEATURE**  
 -S524 = 18 Positions  
 -S524 = 31 Positions  
 -S518 = 49 Positions (31/18)  
**ISA WITHOUT RETENTION FEATURE**  
 -S371 = 18 Positions  
 -S371 = 31 Positions  
 -S420 = 49 Positions (31/18) Dip Solder or Wire Wrap  
 -S605 = 49 Positions (31/18) Right Angle\*\*

**MOUNTING STYLE (Opposite Page)**  
 H = Clearance Holes  
 I = Threaded Inserts  
 S = Side Mounting\*\*  
 N = No Mounting  
 D, W = Flush Mounting  
 T, X = Flush Mounting With Threaded Inserts

**TERMINATION TYPE (Opposite Page)**  
**Hairpin Bellows \***  
 CS = .025" [0.64mm] Square Dip Solder  
 CM = .025" [0.64mm] Square Wire Wrap  
 CA, CB, CC = .025" [0.64mm] Square Right Angle  
 CW, CT = .015" [0.38mm] x .025" [0.64mm] Dip Solder  
**Loop Bellows**  
 RS = .025" [0.64mm] Square Dip Solder  
 TK = .025" [0.64mm] Round Dip Solder  
 RM = .025" [0.64mm] Square Wire Wrap  
 TA, TB, TM = .025" [0.64mm] Square Right Angle  
**\* Available in B or C Plating and Phosphor Bronze only**  
**Consult Factory for Cantilever Terminations**

Sullins Female Card Edge

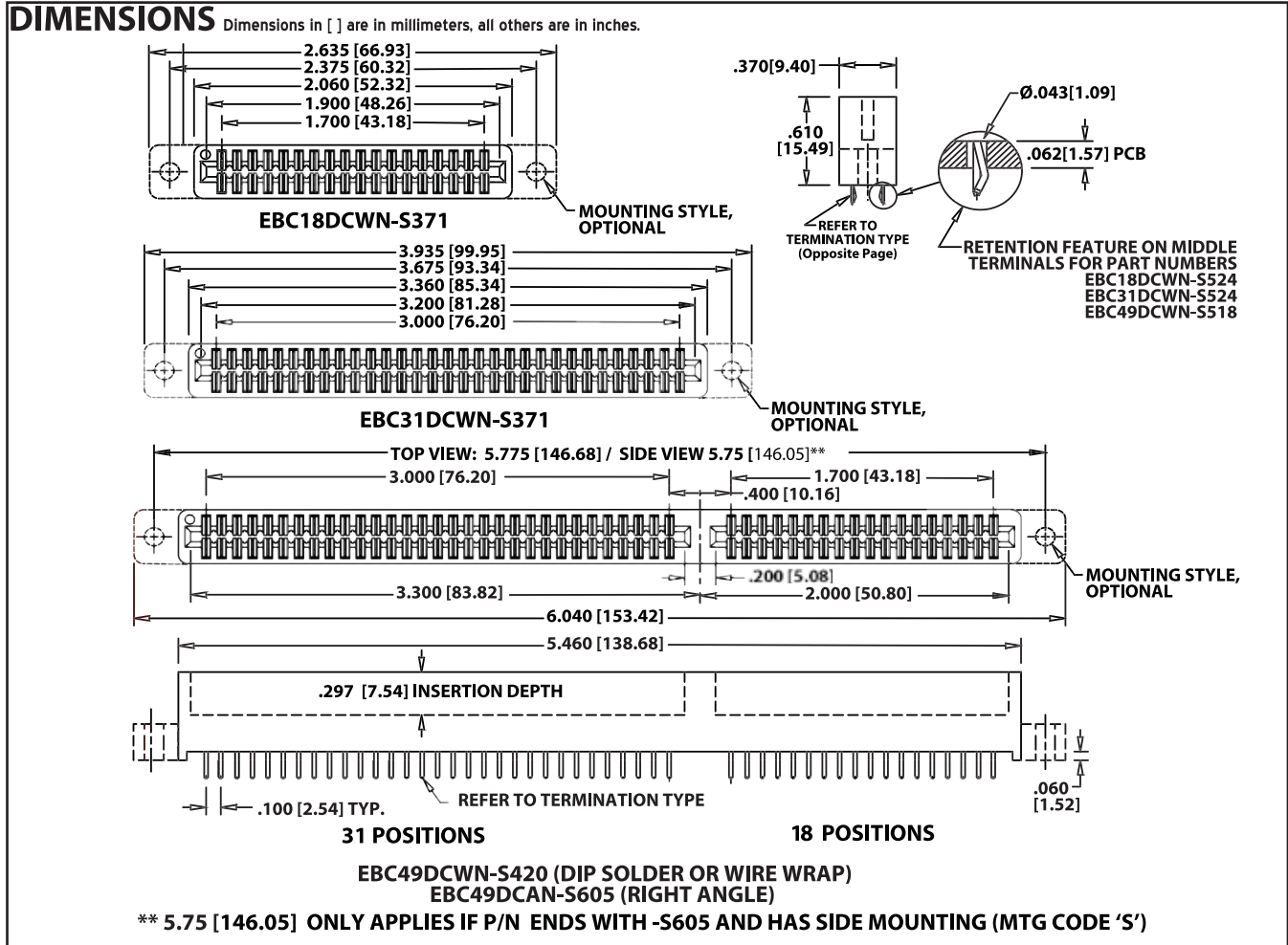



# Female Card Edge

**.100" [2.54 mm] Contact Centers, .690" [17.52 mm] Insulator Height**  
**Make Before Break Dip Solder/Card Extender/Right Angle**

## SPECIFICATIONS

- Accommodates .062" ± .008" [1.57 ± .20] PC board
- PA9T insulator
- Molded-in key available
- 3 amp current rating
- 30 milli ohm maximum at rated current
- UL Flammability Rating: 94V-0

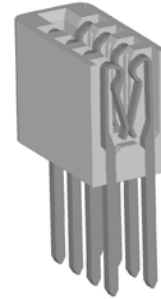

## READOUT

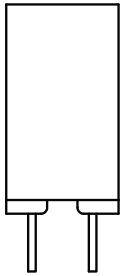

DUAL (D)

## MOUNTING STYLE

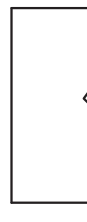

NO MOUNTING EARS (N)

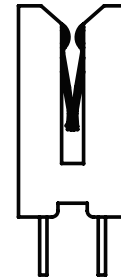

OPEN CARD SLOT (B)

## TERMINATION TYPE

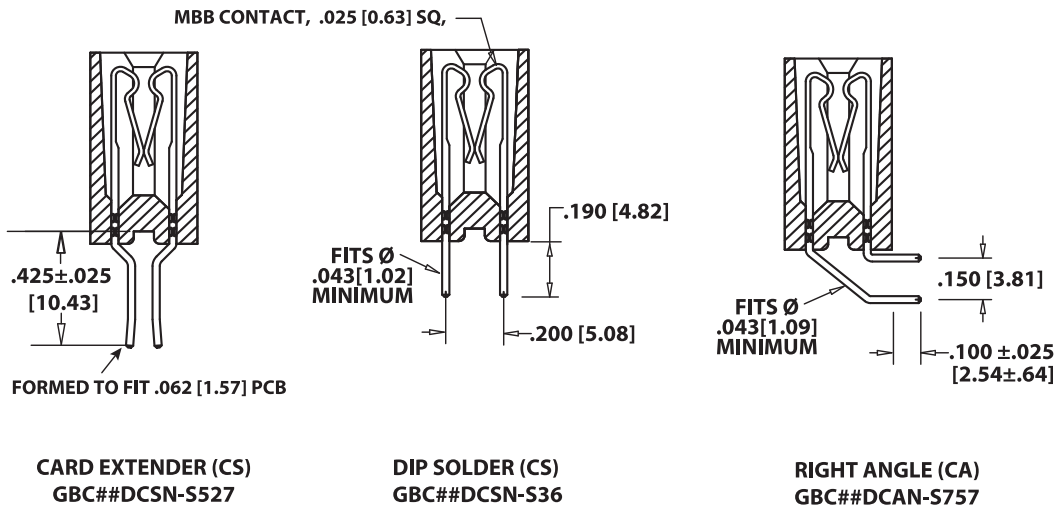



**.100" [2.54 mm] Contact Centers, .690" [17.52 mm] Insulator Height  
Make Before Break Dip Solder/Card Extender/Right Angle**

**PART NUMBER OPTIONS**

**MATERIALS (INSULATOR/CONTACT)**

G = PA9T/Phosphor Bronze  
(Consult Factory for Other Materials)

**CONTACT FINISH - RoHS Compliant**

All platings are Lead Free and have .000050" Nickel underplate  
**Contact Surface Termination**

B = .000010" Gold .000100" Pure Tin, Matte  
C = .000030" Gold .000100" Pure Tin, Matte

**CONTACT CENTERS**

C = .100" [2.54mm]

**NUMBER OF CONTACT POSITIONS**

See Chart Below

**G B C 10 D CS N - S36**

**MODIFICATION CODE** (Consult Factory)

-S757 = MBB, .150" [3.81mm] Row to Row on Right Angle  
-S527 = MBB, Card Extender Accepts .062" [1.57] PCB  
-S36 = MBB, Straight Dip-Solder

**MOUNTING STYLE**

N = No Mounting

**TERMINATION TYPE (Opposite Page)**  
**Hairpin Bellows**

CS = Dip Solder .025" [.64] Square  
CA = Right Angle, .100" [2.54]

**READOUT (Opposite Page)**

D = Dual

**DIMENSIONS**

Dimensions in [ ] are in millimeters, all others are in inches.

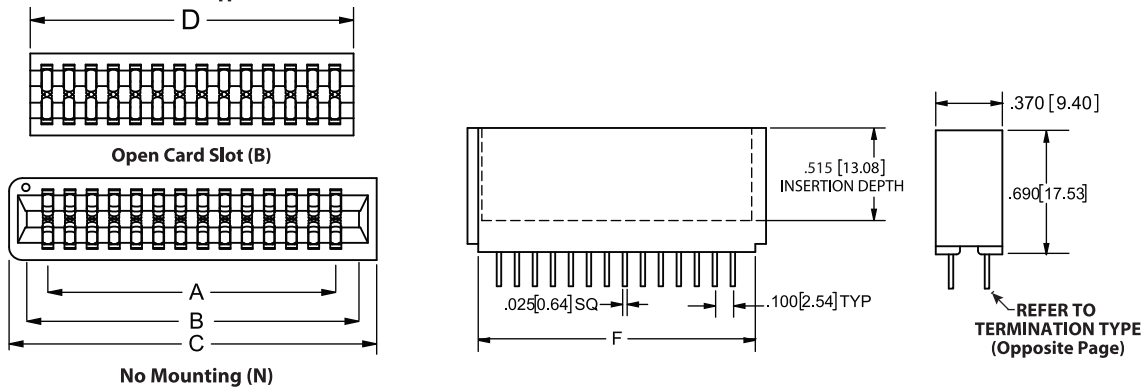

POSITIONS/ CONTACTS	A±.008[0.20]		B±.008[0.20]		C±.015[0.38]		D±.020[0.51]		F±.020[0.51]	
	IN	MM	IN	MM	IN	MM	IN	MM	IN	MM
02/04*	0.100	2.54	0.300	7.62	0.460	11.68	0.250	6.35	0.340	8.64
04/08*	0.300	7.62	0.500	12.70	0.660	16.76	0.450	11.43	0.540	13.72
06/12*	0.500	12.70	0.700	17.78	0.860	21.84	0.650	16.51	0.740	18.80
08/16*	0.700	17.78	0.900	22.86	1.060	26.92	0.850	21.59	0.940	23.88
10/20*	0.900	22.86	1.100	27.94	1.260	32.00	1.050	26.67	1.140	28.96
12/24	1.100	27.94	1.300	33.02	1.460	37.08	1.250	31.75	1.340	34.04
14/28	1.300	33.02	1.500	38.10	1.660	42.16	1.450	36.83	1.540	39.12
16/32*	1.500	38.10	1.700	43.18	1.860	47.24	1.650	41.91	1.740	44.20
18/36*	1.700	43.18	1.900	48.26	2.060	52.32	1.850	46.99	1.940	49.28
20/40*	1.900	48.26	2.100	53.34	2.260	57.40	2.050	52.07	2.140	54.36
22/44*	2.100	53.34	2.300	58.42	2.460	62.48	2.250	57.15	2.340	59.44
24/48*	2.300	58.42	2.500	63.50	2.660	67.56	2.450	62.23	2.540	64.52
26/52*	2.500	63.50	2.700	68.58	2.860	72.64	2.650	67.31	2.740	69.60
28/56*	2.700	68.58	2.900	73.66	3.060	77.72	2.850	72.39	2.940	74.68
30/60*	2.900	73.66	3.100	78.74	3.260	82.80	3.050	77.47	3.140	79.76
32/64*	3.100	78.74	3.300	83.82	3.460	87.88	3.250	82.55	3.340	84.84
34/68*	3.300	83.82	3.500	88.90	3.660	92.96	3.450	87.63	3.540	89.92
36/72*	3.500	88.90	3.700	93.98	3.860	98.04	3.650	92.71	3.740	95.00
38/76*	3.700	93.98	3.900	99.06	4.060	103.12	3.850	97.79	3.940	100.08
40/80*	3.900	99.06	4.100	104.14	4.260	108.20	4.050	102.87	4.140	105.16
42/84*	4.100	104.14	4.300	109.22	4.460	113.28	4.250	107.95	4.340	110.24
44/88*	4.300	109.22	4.500	114.30	4.660	118.36	4.450	113.03	4.540	115.32
46/92*	4.500	114.30	4.700	119.38	4.860	123.44	4.650	118.11	4.740	120.40
48/96*	4.700	119.38	4.900	124.46	5.060	128.52	4.850	123.19	4.940	125.48
50/100	4.900	124.46	5.100	129.54	5.260	133.60	5.050	128.27	5.140	130.56

\*Consult Factory for Availability 'N' Mounting. 'B' Mounting Available in All Positions



# Female Card Edge

**.100" [2.54 mm] Contact Centers, .560" [14.22 mm] Profile, .400" [10.16 mm] Wide Body  
Double Point Contact, Dip Solder/Wire Wrap/Right Angle/Card Extender**

## SPECIFICATIONS

- Accommodates .062" ± .008 [1.57 ± .20] PC board
- PPS, PBT or PA9T insulator
- 3 amp current rating
- 30 milli ohm maximum at rated current
- UL Flammability Rating: 94V-0

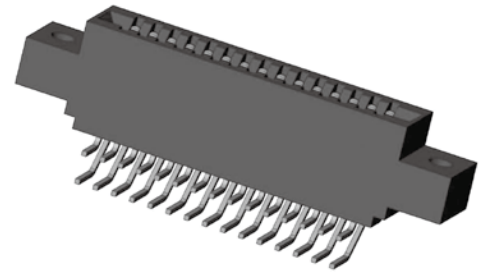

## TERMINATION TYPE

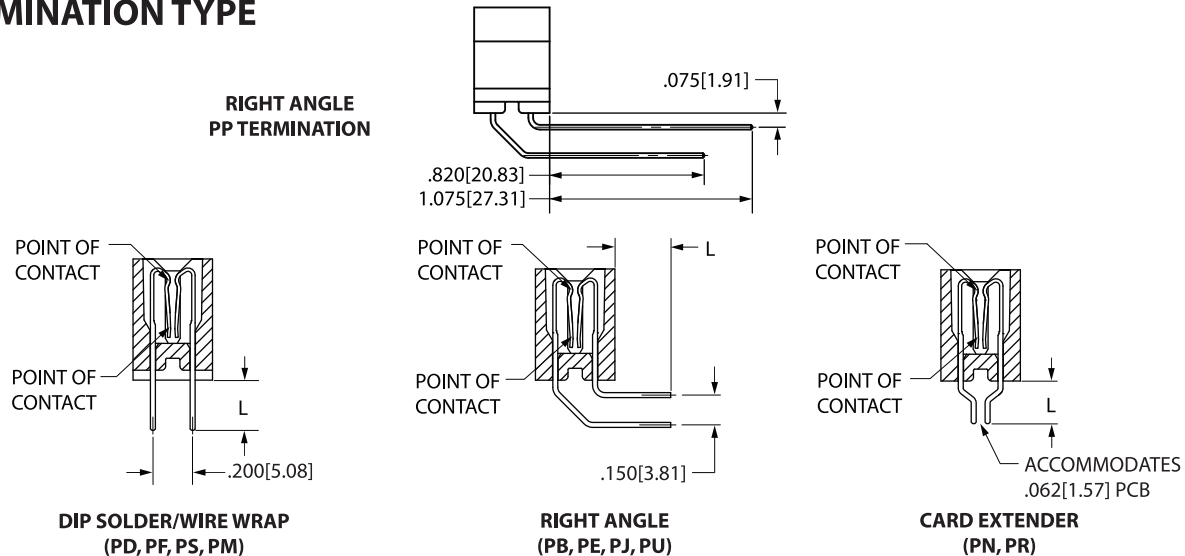

**DIP SOLDER/WIRE WRAP**  
(PD, PF, PS, PM)

**RIGHT ANGLE**  
(PB, PE, PJ, PU)

**CARD EXTENDER**  
(PN, PR)

TERMINATION	TERMINATION TYPE	* POST LENGTH L ±.025 [.64]	FITS MIN. HOLE SIZE	STANDOFF
<b>PD</b>	DIP SOLDER	.160 [4.06]	.043 [1.09]	YES
<b>PS</b>	DIP SOLDER	.190 [4.83]	.043 [1.09]	YES
<b>PF</b>	DIP SOLDER	.270 [6.86]	.043 [1.09]	YES
<b>PM</b>	WIRE WRAP	.560 [14.22]	.043 [1.09]	YES
<b>PB</b>	RIGHT ANGLE	.100 [2.54]	.043 [1.09]	NO
<b>PG</b>	RIGHT ANGLE	.140 [3.56]	.043 [1.09]	NO
<b>PE</b>	RIGHT ANGLE	.180 [4.57]	.043 [1.09]	NO
<b>PU</b>	RIGHT ANGLE	.250 [6.35]	.043 [1.09]	NO
<b>PJ</b>	RIGHT ANGLE	.500 [12.70]	.043 [1.09]	NO
<b>PP</b>	RIGHT ANGLE	SEE ABOVE	.043 [1.09]	NO
<b>PN</b>	CARD EXTENDER	.225 [5.73]	N/A	NO
<b>PR</b>	CARD EXTENDER	.595 [15.12]	N/A	NO

\* OTHER POST LENGTHS AVAILABLE, CONTACT FACTORY.

## MOUNTING STYLE (Standoffs included on straight terminations only.)

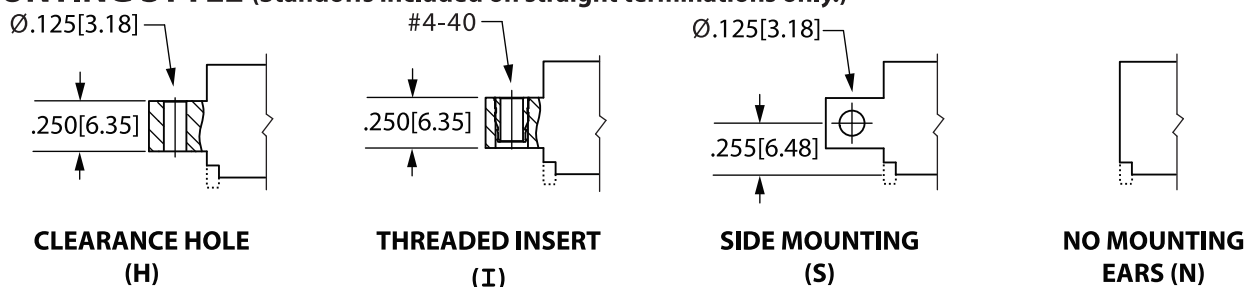

**CLEARANCE HOLE**  
(H)

**THREADED INSERT**  
(I)

**SIDE MOUNTING**  
(S)

**NO MOUNTING EARS**  
(N)



**.100" [2.54 mm] Contact Centers, .560" [14.22 mm] Profile, .400" [10.16 mm] Wide Body  
Double Point Contact, Dip Solder/Wire Wrap/Right Angle/Card Extender**

**PART NUMBER OPTIONS**

**MATERIALS (Insulator /Contact)**

- E = PBT/Phosphor Bronze
- R = PPS/Phosphor Bronze
- G = PA9T/Phosphor Bronze
- H = PBT/Beryllium Copper
- A = PPS/Beryllium Copper
- J = PA9T/Beryllium Copper
- (Consult Factory for Other Materials)

**CONTACT FINISH - RoHS Compliant**

All platings are Lead Free and have .000050" Nickel underplate

Contact Surface	Termination
B = .000010" Gold	.000100" Pure Tin, Matte
C = .000030" Gold	.000100" Pure Tin, Matte

**CONTACT CENTERS**

C = .100" [2.54mm]

**NUMBER OF CONTACT POSITIONS**

See Chart Below

**E B C 10 D PD H - Sxxx**

**MODIFICATION CODE (Consult Factory)**

OMIT FOR STANDARD

**MOUNTING STYLE (Opposite Page)**

- H = Clearance Holes
- I = Threaded Inserts
- S = Side Mounting
- N = No Mounting

**TERMINATION TYPE (Opposite Page)**

- PD, PF, PS = .025" [.64] Square Dip Solder
- PM = .025" [.64] Square Wire Wrap
- PB, PG, PE, PJ, PU, PP = .025" [.64mm] Square Right Angle
- PN, PR = .025" [.64mm] Square Card Extender

**READOUT (Opposite Page)**

D = Dual

**DIMENSIONS**

Dimensions in [ ] are in millimeters, all others are in inches.

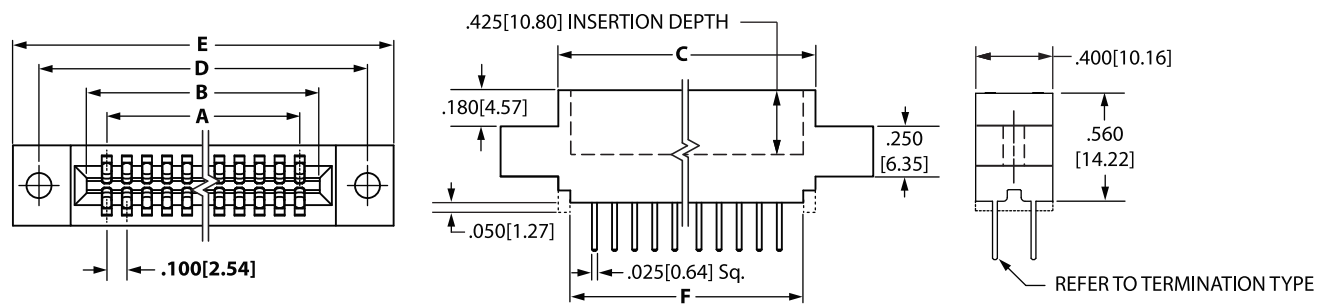

Tolerances with PPS Insulator Material may vary slightly due to shrinkage differential; Consult Factory.

POSITIONS/ CONTACTS	INCHES						[MILLIMETERS]					
	A±.008	B±.008	C±.015	D±.010	E±.020	F±.015	A±0.20	B±0.20	C±0.38	D±0.25	E±0.51	F±0.38
06/12*	0.500	0.700	0.860	1.175	1.435	0.740	12.70	17.78	21.84	29.85	36.45	18.80
07/14*	0.600	0.800	0.960	1.275	1.535	0.840	15.24	20.32	24.38	32.39	38.99	21.34
08/16	0.700	0.900	1.060	1.375	1.635	0.940	17.78	22.86	26.92	34.93	41.53	23.88
10/20	0.900	1.100	1.260	1.575	1.835	1.140	22.86	27.94	32.00	40.01	46.61	28.96
12/24*	1.100	1.300	1.460	1.775	2.035	1.340	27.94	33.02	37.08	45.09	51.69	34.04
13/26*	1.200	1.400	1.560	1.875	2.135	1.440	30.48	35.56	39.62	47.63	54.23	36.58
15/30	1.400	1.600	1.760	2.075	2.335	1.640	35.56	40.64	44.70	52.71	59.31	41.66
17/34*	1.600	1.800	1.960	2.275	2.535	1.840	40.64	45.72	49.78	57.79	64.39	46.74
18/36*	1.700	1.900	2.060	2.375	2.635	1.940	43.18	48.26	52.32	60.33	66.93	49.28
20/40	1.900	2.100	2.260	2.575	2.835	2.140	48.26	53.34	57.40	65.41	72.01	54.36
22/44*	2.100	2.300	2.460	2.775	3.035	2.340	53.34	58.42	62.48	70.49	77.09	59.44
24/48*	2.300	2.500	2.660	2.975	3.235	2.540	58.42	63.50	67.56	75.57	82.17	64.52
25/50*	2.400	2.600	2.760	3.075	3.335	2.640	60.96	66.04	70.10	78.11	84.71	67.06
28/56*	2.700	2.900	3.060	3.375	3.635	2.940	68.58	73.66	77.72	85.73	92.33	74.68
30/60	2.900	3.100	3.260	3.575	3.835	3.140	73.66	78.74	82.80	90.81	97.41	79.76
31/62*	3.000	3.200	3.360	3.675	3.935	3.240	76.20	81.28	85.34	93.35	99.95	82.30
35/70*	3.400	3.600	3.760	4.075	4.335	3.640	86.36	91.44	95.50	103.51	110.11	92.46
36/72*	3.500	3.700	3.860	4.175	4.435	3.740	88.90	93.98	98.04	106.05	112.65	95.00
40/80*	3.900	4.100	4.260	4.575	4.835	4.140	99.06	104.14	108.20	116.21	122.81	105.16
43/86	4.200	4.400	4.560	4.875	5.135	4.440	106.68	111.76	115.82	123.83	130.43	112.78
44/88*	4.300	4.500	4.660	4.975	5.235	4.540	109.22	114.30	118.36	126.37	132.97	115.32
49/98*	4.800	5.000	5.160	5.475	5.735	5.040	121.92	127.00	131.06	139.07	145.67	128.02
50/100	4.900	5.100	5.260	5.575	5.835	5.140	124.46	129.54	133.60	141.61	148.21	130.56
55/110*	5.400	5.600	5.760	6.075	6.335	5.640	137.16	142.24	146.30	154.31	160.91	143.26
60/120*	5.900	6.100	6.260	6.575	6.835	6.140	149.86	154.94	159.00	167.01	173.61	155.96
61/122*	6.000	6.200	6.360	6.675	6.935	6.240	152.40	157.48	161.54	169.55	176.15	158.50
65/130*	6.400	6.600	6.760	7.075	7.335	6.640	162.56	167.64	171.70	179.71	186.31	168.66
70/140	6.900	7.100	7.260	7.575	7.835	7.140	175.26	180.34	184.40	192.41	199.01	181.36

\* Consult Factory For Availability.



# Female Card Edge

**.125" [3.18 mm] Contact Centers, .431" [10.95 mm] Insulator Height**  
**Dip Solder/Eyelet/Right Angle for .062" [1.57] or .031" [0.79] Mating PCB**

## SPECIFICATIONS

- Accommodates .062" ± .008" [1.57 ± .20] PC board  
(Consult factory for .031" ± .008" [.79 ± .20], .093" ± .008" [2.36 ± .20] and .125" ± .008" [3.18 ± .20] boards)
- Molded-in key available
- 3 amp current rating
- 30 milli ohm maximum at rated current
- UL Flammability Rating: 94V-0

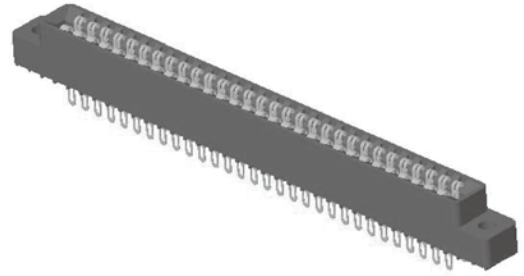

### READOUT

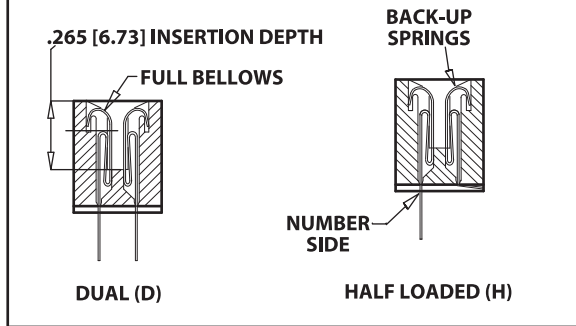

### POLARIZING KEY

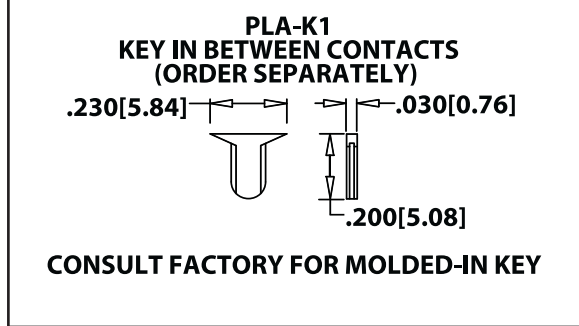

## TERMINATION TYPE

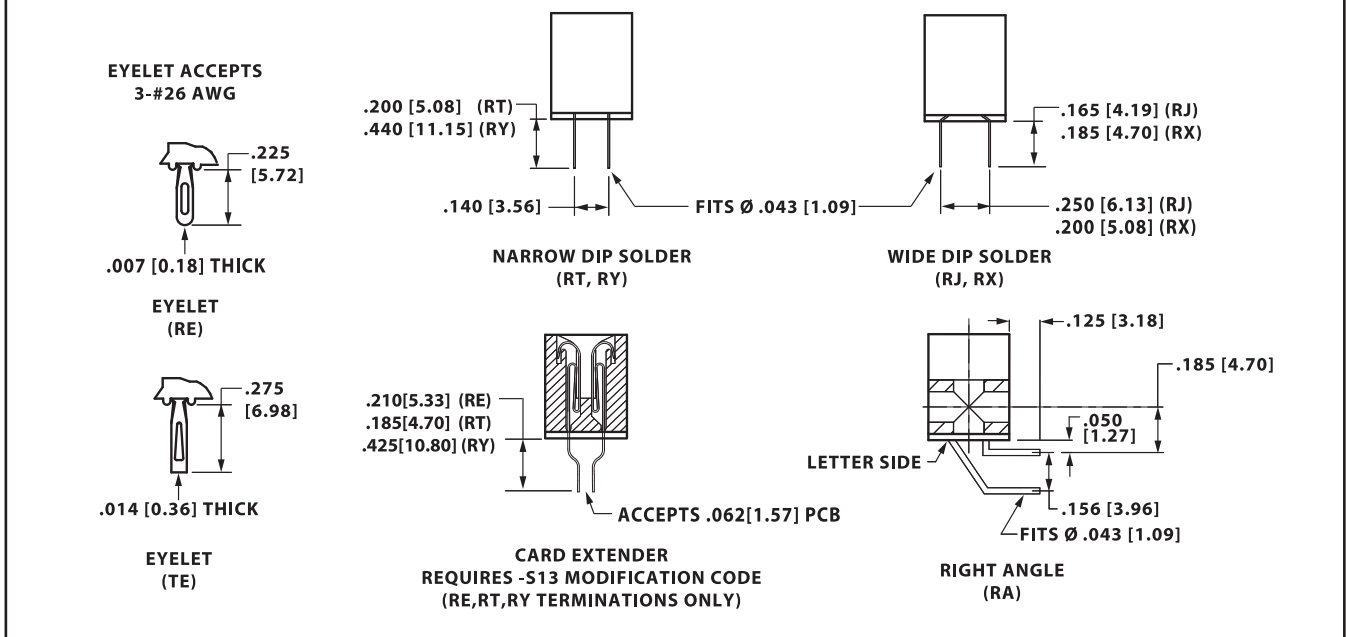

## MOUNTING STYLE

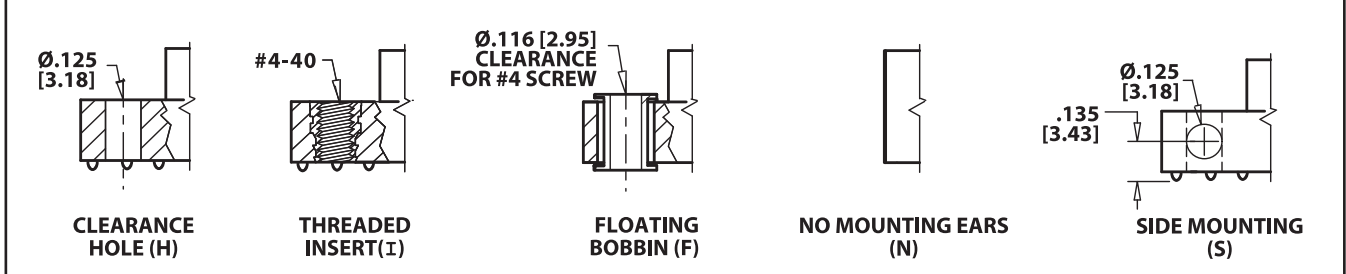



**.125" [3.18 mm] Contact Centers, .431" [10.95 mm] Insulator Height**  
**Dip Solder/Eyelet/Right Angle for .062" [1.57] or .031" [0.79] Mating PCB**

**PART NUMBER OPTIONS**

**MATERIALS (Insulator/Contact)**

- E = PBT/Phosphor Bronze (Standard)
- R = PPS/Phosphor Bronze
- G = PA9T/Phosphor bronze
- H = PBT/Beryllium Copper
- A = PPS/Beryllium Copper
- J = PA9T/Beryllium Copper
- \*F = PPS/Spinodal (Overall Gold Plating Only)
- Consult Factory for Special Soldering Guidelines
- \*C = PPS/Beryllium Nickel (Overall Gold Plating Only)
- \*W = PEEK/Beryllium Nickel (Overall Gold Plating Only)
- \*Consult Factory for availability.

**CONTACT FINISH - RoHS Compliant**

All platings are Lead Free and have .000050" Nickel underplate

	Contact Surface	Termination
B =	.000010" Gold	.000100" Pure Tin, Matte
C =	.000030" Gold	.000100" Pure Tin, Matte
G =	.000010" Gold	.000005" Gold
Y =	.000030" Gold	.000005" Gold
	Contact Surface	Overall Plating
S =	.000010" Gold	.000010" Gold
M =	.000030" Gold	.000010" Gold
E =	.000100" Pure Tin, Matte	.000100" Pure Tin, Matte

**CONTACT CENTERS**

A = .125" [3.18mm]

**E B A 43 D R E H - Sxxx**

**MODIFICATION CODE (Consult Factory)**  
OMIT FOR STANDARD

- S13 = Card Extender Accepts .062" [1.57] PCB (RE, RT, RY Terminations Only)
- S734 = .031" ± .008" [.79 ± .20] Thick PCB

**MOUNTING STYLE (Opposite Page)**

- H = .125" [3.18mm] Clearance Holes
- N = No Mounting
- S = Side Mounting
- I = Threaded Insert
- F = Floating Bobbin

**TERMINATION TYPE (Opposite Page)**

- RA = Right Angle
- RE = Eyelet (Standard)
- TE = Eyelet (Overall Plated Only)
- RT = .140" [3.56mm] x .200" [5.08mm] Dip Solder
- RY = .140" [3.56mm] x .440" [11.18mm] Dip Solder
- RX = .200" [5.08mm] x .185" [4.70mm] Dip Solder
- RJ = .250" [6.35mm] x .165" [4.19mm] Dip Solder

**READOUT (Opposite Page)**

- D = Dual
- H = Half Loaded

**NUMBER OF CONTACT POSITIONS**

See Chart Below

**DIMENSIONS**

Dimensions in [ ] are in millimeters, all others are in inches.

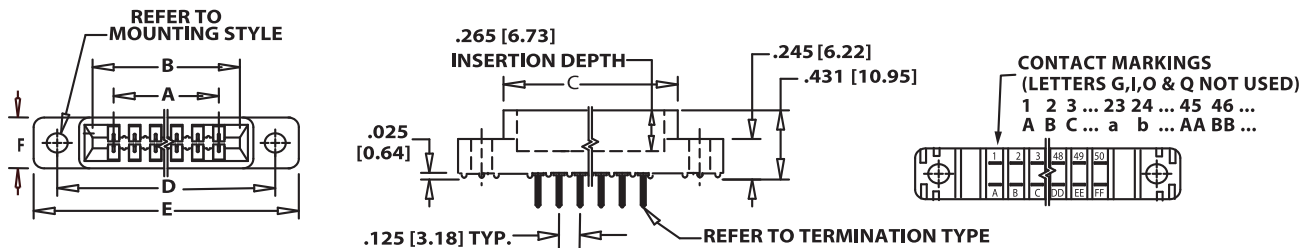

Tolerances with PPS Insulator Material may vary slightly due to shrinkage differential; Consult Factory.

Positions/ Contacts	INCHES						[MILLIMETERS]					
	A±.008	B±.008	C±.015	D±.010	E±.020	F+.005/ -.015	A±0.20	B±0.20	C±0.38	D±0.25	E±0.51	F+0.13 /- 0.38
06/12	0.625	0.875	1.035	1.295	1.575	0.330	15.88	22.23	26.29	32.89	40.01	8.38
10/20	1.125	1.375	1.535	1.795	2.075		28.58	34.93	38.99	45.59	52.71	
14/28	1.625	1.875	2.035	2.295	2.575		41.28	47.63	51.69	58.29	65.41	
15/30	1.750	2.000	2.160	2.420	2.700		44.45	50.80	54.86	61.47	68.58	
18/36	2.125	2.375	2.535	2.795	3.075		53.98	60.33	64.39	70.99	78.11	
22/44	2.625	2.875	3.035	3.295	3.575		66.68	73.03	77.09	83.69	90.81	
28/56	3.375	3.625	3.785	4.045	4.325		85.73	92.08	96.14	102.74	109.86	
30/60	3.625	3.875	4.035	4.295	4.575		92.08	98.43	102.49	109.09	116.21	
31/62	3.750	4.000	4.160	4.420	4.700		95.25	101.60	105.66	112.27	119.38	
35/70	4.250	4.500	4.660	4.920	5.200		107.95	114.30	118.36	124.97	132.08	
36/72	4.375	4.625	4.785	5.045	5.325		111.13	117.48	121.54	128.14	135.26	
37/74	4.500	4.750	4.910	5.170	5.450		114.30	120.65	124.71	131.32	138.43	
40/80	4.875	5.125	5.285	5.545	5.825		123.83	130.18	134.24	140.84	147.96	
43/86	5.250	5.500	5.660	5.920	6.200	133.35	139.70	143.76	150.37	157.48		
44/88	5.375	5.625	5.785	6.045	6.325	136.53	142.88	146.94	153.54	160.66		
49/98	6.000	6.250	6.410	6.670	6.950	152.40	158.75	162.81	169.42	176.53		
50/100	6.125	6.375	6.535	6.795	7.075	155.58	161.93	165.99	172.59	179.71		



# Female Card Edge

**.125" [3.18 mm] Contact Centers, .610" [15.49 mm] Insulator Height**  
**Dip Solder/Wire Wrap/Right Angle**

## SPECIFICATIONS

- Accommodates .062" ± .008" [1.57 ± .20] PC board  
(Consult factory for .031" ± .008" [.79 ± .20],  
See next 2 pages for .093" ± .008" [2.36 ± .20]  
and .125" ± .008" [3.18 ± .20] PC boards)
- PBT, PPS or PA9T insulator
- Molded-in key available
- 3 amp current rating
- 30 milli ohm maximum at rated current
- Consult Factory for (MBB) Contacts
- UL Flammability Rating: 94V-0

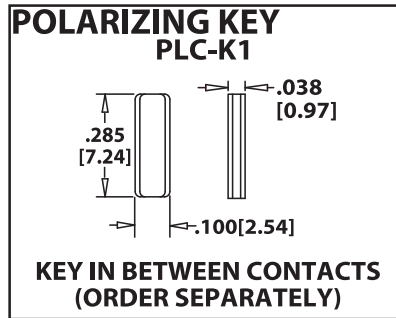
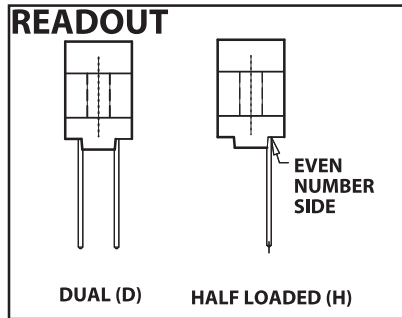
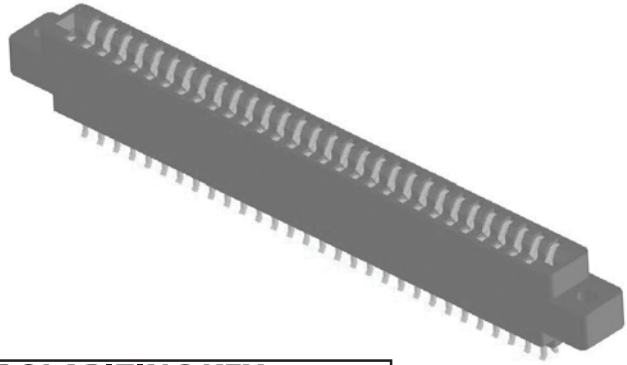

## TERMINATION TYPE

### HAIRPIN BELLOWS

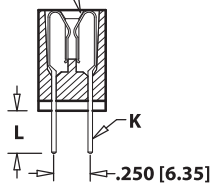

HAIRPIN BELLOWS  
(CK,CS,CM,CW,CT)

### LOOP BELLOWS

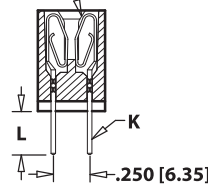

LOOP BELLOWS  
(TK,RS,RM,CK)

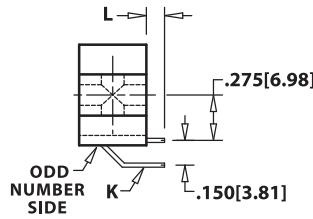

RIGHT ANGLE, DIP SOLDER  
(CA,CB,CC,TA,TB,TM)

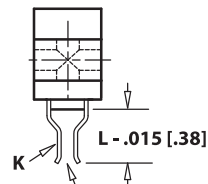

CARD EXTENDER  
REQUIRES -S288 MODIFICATION CODE  
(CS,CM,CT,RS,CK,TK,RM)

ACCEPTS .062 [1.57] PCB

HAIRPIN BELLOWS	LOOP BELLOWS	TERMINATION TYPE	POST CROSS SECTION K	POST LENGTH L ± .025[.64]	FITS MIN. HOLE SIZE
	TK, CK	DIP SOLDER	.025 [.64] ROUND	.190 [4.83]	.033 [0.84]
	RS	DIP SOLDER	.025 [.64] SQUARE	.190 [4.83]	.040 [1.02]
CM	RM	WIRE WRAP	.025 [.64] SQUARE	.560 [14.20]	.040 [1.02]
CA	TA	RIGHT ANGLE	.025 [.64] SQUARE	.100 [2.54]	.043 [1.09]
CB	TB	RIGHT ANGLE	.025 [.64] SQUARE	.180 [4.57]	.043 [1.09]
CC	TM	RIGHT ANGLE	.025 [.64] SQUARE	.250 [6.35]	.043 [1.09]
CW		DIP SOLDER	.015 x .025 [.38 x .64]	.125 [3.18]	.035 [0.89]
CT		DIP SOLDER	.015 x .025 [.38 x .64]	.170 [4.32]	.035 [0.89]
CS		DIP SOLDER	.025 [.64] SQUARE	.160 [4.06]	.040 [1.02]

## MOUNTING STYLE

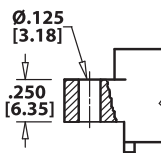

CLEARANCE HOLE (H)

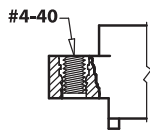

THREADED INSERT (I)

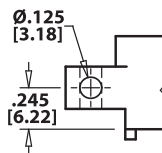

SIDE MOUNTING (S)



NO MOUNTING EARS (N)

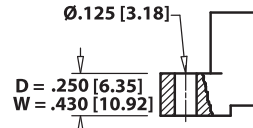

FLUSH MOUNTING (D, W)

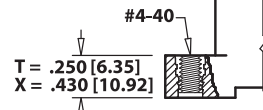

FLUSH MOUNTING WITH THREADED INSERT (T, X)



**.125" [3.18 mm] Contact Centers, .610" [15.49 mm] Insulator Height  
Dip Solder/Wire Wrap/Right Angle**

**PART NUMBER OPTIONS**

**MATERIALS (Insulator/Contact)**

- E = PBT/Phosphor Bronze (Standard)
- R = PPS/Phosphor Bronze
- G = PA9T/Phosphor Bronze
- A = PPS/Beryllium Copper
- J = PA9T/Beryllium Copper
- (Consult Factory for Other Materials)

**CONTACT FINISH - RoHS Compliant**

All platings are Lead Free and have .000050" Nickel underplate

**Contact Surface Termination**

- B = .000010" Gold .000100" Pure Tin, Matte
- C = .000030" Gold .000100" Pure Tin, Matte
- G = .000010" Gold .000005" Gold
- Y = .000030" Gold .000005" Gold

**Overall Plating**

- S = .000010" Gold .000010" Gold
- M = .000030" Gold .000010" Gold
- E = .000100" Pure Tin, Matte .000100" Pure Tin, Matte

**CONTACT CENTERS**

- A = .125" [3.18mm]

**NUMBER OF CONTACT POSITIONS**

See Chart Below

**READOUT (Opposite Page)**

- D = Dual
- H = Half Loaded

**E B A 50 D CM H - Sxxx**

**MODIFICATION CODE (Consult Factory)**  
OMIT FOR STANDARD

-S288 = Card Extender Accepts .062" [1.57] PCB

**MOUNTING STYLE (Opposite Page)**

- H = Clearance Holes
- I = Threaded Inserts
- S = Side Mounting
- N = No Mounting
- W = Flush Mounting
- D = Flush Mounting
- X = Flush Mounting with Threaded Inserts
- T = Flush Mounting with Threaded Inserts

**TERMINATION TYPE (Opposite Page)**

**Hairpin Bellows \*\***

\*\*Available with B or C plating and Phosphor Bronze Only

- CS = .025" [0.64mm] Square Dip Solder
- CM = .025" [0.64mm] Square Wire Wrap
- CA, CB, CC = .025" [0.64mm] Square Right Angle
- CW, CT = .015" x .025" [0.38 x .64] Dip Solder

**Loop Bellows**

- RS = .025" [0.64mm] Square Dip Solder
- CK, TK = .025" [0.64mm] Round Dip Solder
- RM = .025" [0.64mm] Square Wire Wrap
- TA, TB, TM = .025" [0.64mm] Square Right Angle

**DIMENSIONS**

Dimensions in [ ] are in millimeters, all others are in inches.

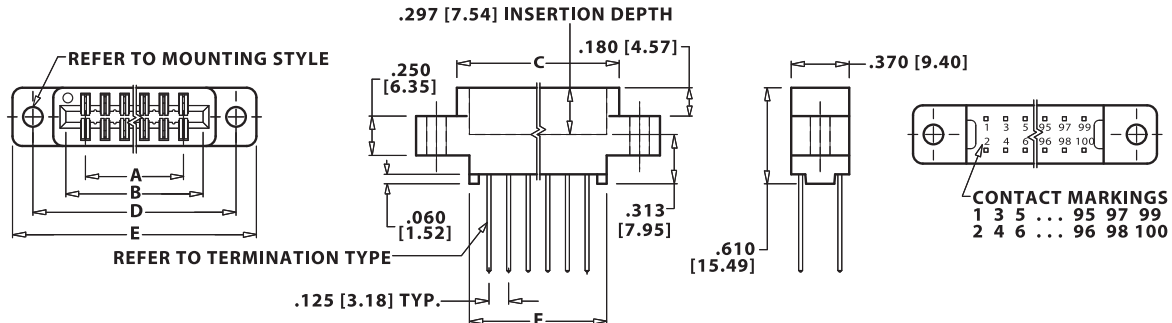

Tolerances with PPS Insulator Material may vary slightly due to shrinkage differential; Consult Factory.

POSITIONS/ CONTACTS	INCHES						[MILLIMETERS]					
	A±.008	B±.008	C±.015	D±.010	E±.020	F±.015	A±0.20	B±0.20	C±0.38	D±0.25	E±0.51	F±0.38
06/12	0.625	0.875	1.035	1.295	1.555	0.875	15.88	22.23	26.29	32.89	39.50	22.23
10/20	1.125	1.375	1.535	1.795	2.055	1.375	28.58	34.93	38.99	45.59	52.20	34.93
14/28	1.625	1.875	2.035	2.295	2.555	1.875	41.28	47.63	51.69	58.29	64.90	47.63
15/30	1.750	2.000	2.160	2.420	2.680	2.000	44.45	50.80	54.86	61.47	68.07	50.80
18/36	2.125	2.375	2.535	2.795	3.055	2.375	53.98	60.33	64.39	70.99	77.60	60.33
22/44	2.625	2.875	3.035	3.295	3.555	2.875	66.68	73.03	77.09	83.69	90.30	73.03
24/48	2.875	3.125	3.285	3.545	3.805	3.125	73.03	79.38	83.44	90.04	96.65	79.38
25/50*	3.000	3.250	3.410	3.670	3.930	3.250	76.20	82.55	86.61	93.22	99.82	82.55
28/56	3.375	3.625	3.785	4.045	4.305	3.625	85.73	92.08	96.14	102.74	109.35	92.08
30/60	3.625	3.875	4.035	4.295	4.555	3.875	92.08	98.43	102.49	109.09	115.70	98.43
31/62	3.750	4.000	4.160	4.420	4.680	4.000	95.25	101.60	105.66	112.27	118.87	101.60
32/64	3.875	4.125	4.285	4.545	4.805	4.125	98.43	104.78	108.84	115.44	122.05	104.78
35/70	4.250	4.500	4.660	4.920	5.180	4.500	107.95	114.30	118.36	124.97	131.57	114.30
36/72	4.375	4.625	4.785	5.045	5.305	4.625	111.13	117.48	121.54	128.14	134.75	117.48
40/80	4.875	5.125	5.285	5.545	5.805	5.125	123.83	130.18	134.24	140.84	147.45	130.18
43/86	5.250	5.500	5.660	5.920	6.180	5.500	133.35	139.70	143.76	150.37	156.97	139.70
44/88	5.375	5.625	5.785	6.045	6.305	5.625	136.53	142.88	146.94	153.54	160.15	142.88
49/98	6.000	6.250	6.410	6.670	6.930	6.250	152.40	158.75	162.81	169.42	176.02	158.75
50/100	6.125	6.375	6.535	6.795	7.055	6.375	155.58	161.93	165.99	172.59	179.20	161.93

\* Consult factory for availability.



# Female Card Edge

**.125" [3.18 mm] Contact Centers, .610" [15.49 mm] Insulator Height**  
**Dip Solder/Wire Wrap/Right Angle for .093" [2.36] or .125" [3.18] Mating PCB**

## SPECIFICATIONS

- Accommodates .093" ± .008" [2.36 ± .20] or .125" ± .008" [3.18 ± .20] mating PCB
- PBT, PPS or PA9T insulator
- Molded-in key available
- 3 amp current rating
- 30 milli ohm maximum at rated current
- UL Flammability Rating: 94V-0

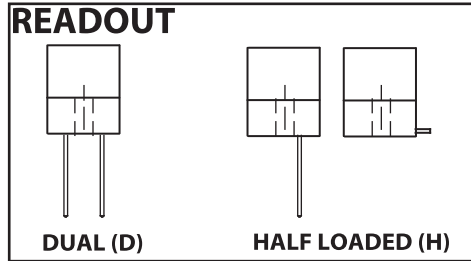
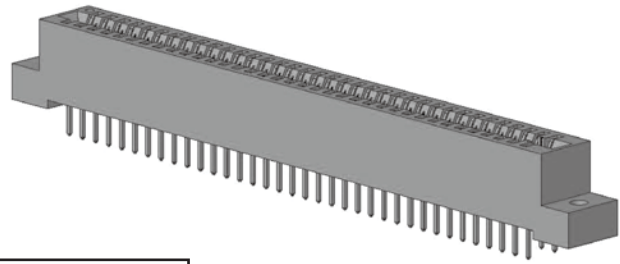

## TERMINATION TYPE

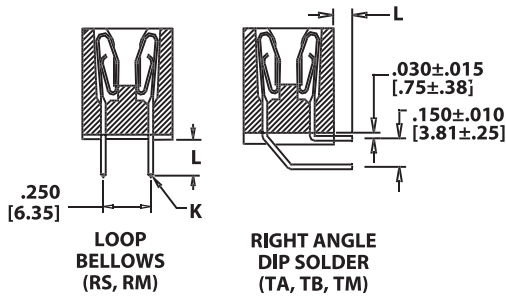

TERMINATION TYPE	POST CROSS SECTION (K)	POST LENGTH L ± .025 [0.64]	FITS MIN. HOLE SIZE
RS DIP SOLDER	.025 [0.64] SQ	.190 [4.83]	.040 [1.02]
RM WIRE WRAP	.025 [0.64] SQ	.560 [14.20]	.040 [1.02]
TA RIGHT ANGLE	.025 [0.64] SQ	.100 [2.54]	.043 [1.09]
TB RIGHT ANGLE	.025 [0.64] SQ	.180 [4.57]	.043 [1.09]
TM RIGHT ANGLE	.025 [0.64] SQ	.250 [6.35]	.043 [1.09]

## PCB LAYOUT

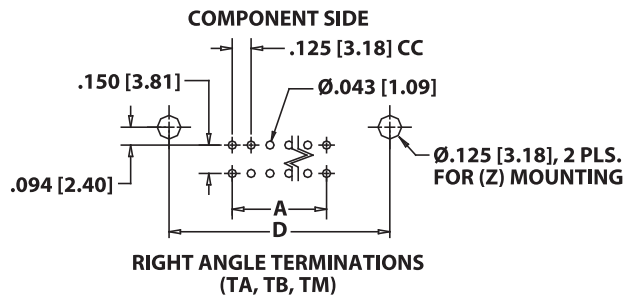
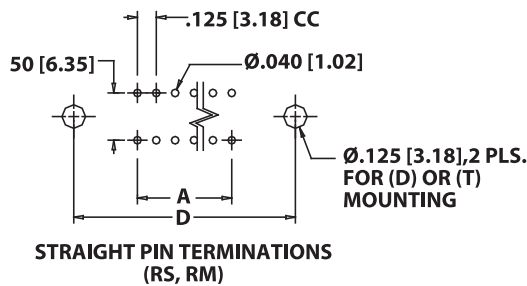

## MOUNTING STYLE

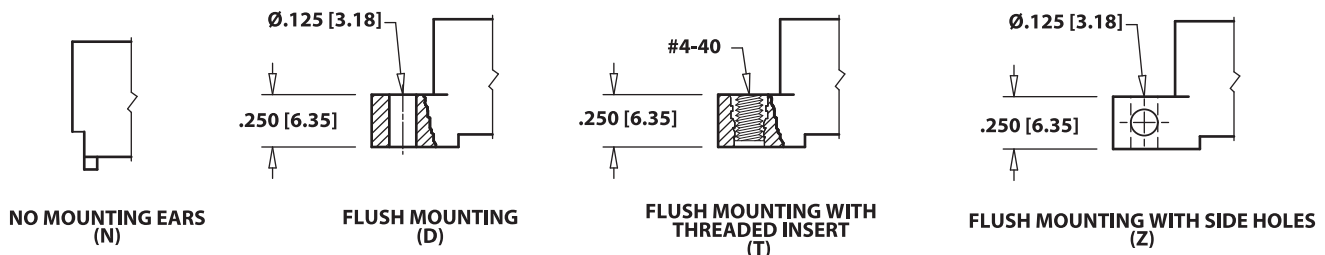



**.125" [3.18 mm] Contact Centers, .610" [15.49 mm] Insulator Height**  
**Dip Solder/Wire Wrap/Right Angle for .093" [2.36] or .125" [3.18] Mating PCB**

**PART NUMBER OPTIONS**

**E B A 50 D RM D - S273**

**MATERIALS (Insulator/Contact)**  
 E = PBT/Phosphor Bronze(Standard)  
 R = PPS/Phosphor Bronze  
 G = PA9T/Phosphor Bronze  
 (Consult Factory for Other Materials)

**CONTACT FINISH - RoHS Compliant**  
**All platings are Lead Free and have .000050" Nickel underplate**

	Contact Surface	Termination
B =	.000010" Gold	.000100" Pure Tin, Matte
C =	.000030" Gold	.000100" Pure Tin, Matte
G =	.000010" Gold	.000005" Gold
Y =	.000030" Gold	.000005" Gold

	Contact Surface	Overall Plating
S =	.000010" Gold	.000010" Gold
M =	.000030" Gold	.000010" Gold
E =	.000100" Pure Tin, Matte	.000100" Pure Tin, Matte

**CONTACT CENTERS**  
 A = .125" [3.18mm]

**MODIFICATION CODE (Consult Factory)**  
 -S273 = FOR .093" ± .008" [2.36 ± .20] THICK MATING PCB  
 -S664 = FOR .125" ± .008" [3.18 ± .20] THICK MATING PCB

**MOUNTING STYLE (Opposite Page)**  
 N = No Mounting  
 D = Flush Mounting  
 T = Flush Mounting With Threaded Inserts  
 Z = Flush Mounting With Side Holes

**TERMINATION TYPE (Opposite Page)**  
 RS = .025" [0.64mm] Square Dip Solder  
 RM = .025" [0.64mm] Square Wire Wrap  
 TA, TB, TM = .025" [0.64mm] Square Right Angle

**READOUT (OPPOSITE PAGE)**  
 D = Dual  
 H = Half Loaded

**NUMBER OF CONTACT POSITIONS**  
 See Chart Below

Sullins Female Card Edge

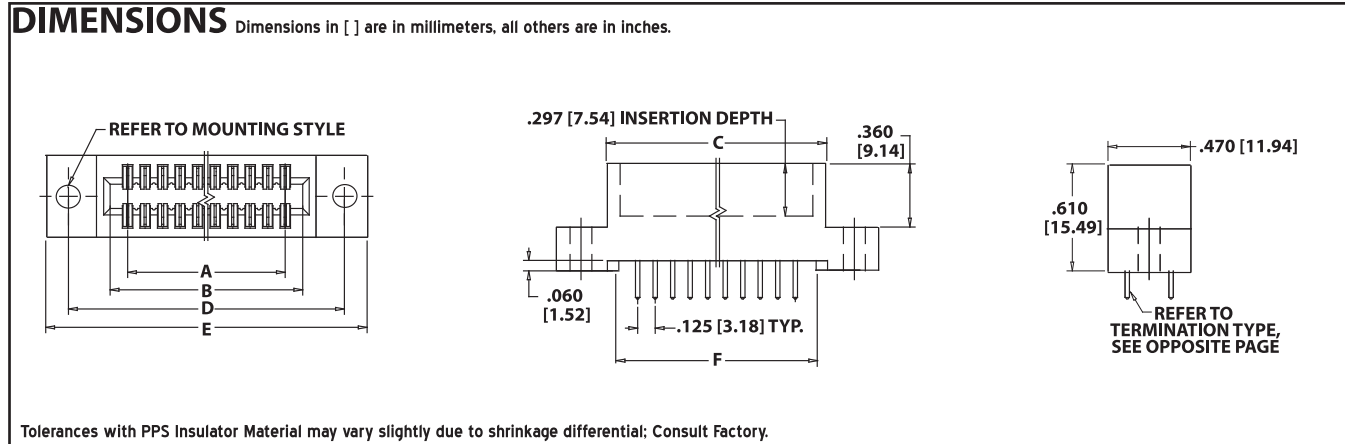

POSITIONS/ CONTACTS	INCHES						[MILLIMETERS]					
	A±.008	B±.008	C±.015	D±.010	E±.020	F±.015	A±0.20	B±0.20	C±0.38	D±0.25	E±0.51	F±0.38
06/12*	0.625	0.875	1.035	1.295	1.555	0.875	15.88	22.23	26.29	32.89	39.50	22.23
10/20*	1.125	1.375	1.535	1.795	2.055	1.375	28.58	34.93	38.99	45.59	52.20	34.93
14/28*	1.625	1.875	2.035	2.295	2.555	1.875	41.28	47.63	51.69	58.29	64.90	47.63
15/30*	1.750	2.000	2.160	2.420	2.680	2.000	44.45	50.80	54.86	61.47	68.07	50.80
18/36*	2.125	2.375	2.535	2.795	3.055	2.375	53.98	60.33	64.39	70.99	77.60	60.33
22/44*	2.625	2.875	3.035	3.295	3.555	2.875	66.68	73.03	77.09	83.69	90.30	73.03
24/48*	2.875	3.125	3.285	3.545	3.805	3.125	73.03	79.38	83.44	90.04	96.65	79.38
25/50*	3.000	3.250	3.410	3.670	3.930	3.250	76.20	82.55	86.61	93.22	99.82	82.55
28/56*	3.375	3.625	3.785	4.045	4.305	3.625	85.73	92.08	96.14	102.74	109.35	92.08
30/60	3.625	3.875	4.035	4.295	4.555	3.875	92.08	98.43	102.49	109.09	115.70	98.43
31/62*	3.750	4.000	4.160	4.420	4.680	4.000	95.25	101.60	105.66	112.27	118.87	101.60
32/64*	3.875	4.125	4.285	4.545	4.805	4.125	98.43	104.78	108.84	115.44	122.05	104.78
35/70*	4.250	4.500	4.660	4.920	5.180	4.500	107.95	114.30	118.36	124.97	131.57	114.30
36/72	4.375	4.625	4.785	5.045	5.305	4.625	111.13	117.48	121.54	128.14	134.75	117.48
40/80*	4.875	5.125	5.285	5.545	5.805	5.125	123.83	130.18	134.24	140.84	147.45	130.18
43/86*	5.250	5.500	5.660	5.920	6.180	5.500	133.35	139.70	143.76	150.37	156.97	139.70
44/88*	5.375	5.625	5.785	6.045	6.305	5.625	136.53	142.88	146.94	153.54	160.15	142.88
49/98*	6.000	6.250	6.410	6.670	6.930	6.250	152.40	158.75	162.81	169.42	176.02	158.75
50/100	6.125	6.375	6.535	6.795	7.055	6.375	155.58	161.93	165.99	172.59	179.20	161.93

\* Consult Factory For Availability.



# Female Card Edge

**.150" [3.81 mm] Contact Centers, .550" [13.97 mm] Insulator Height**  
**Dip Solder/Wire Wrap**

## SPECIFICATIONS

- Accommodates .062" ± .008" [1.57 ± .20] PC board
- PBT, PPS or PA9T insulator
- Molded-in key available
- 3 amp current rating
- 30 milli ohm max. at rated current
- UL Flammability Rating: 94V-0

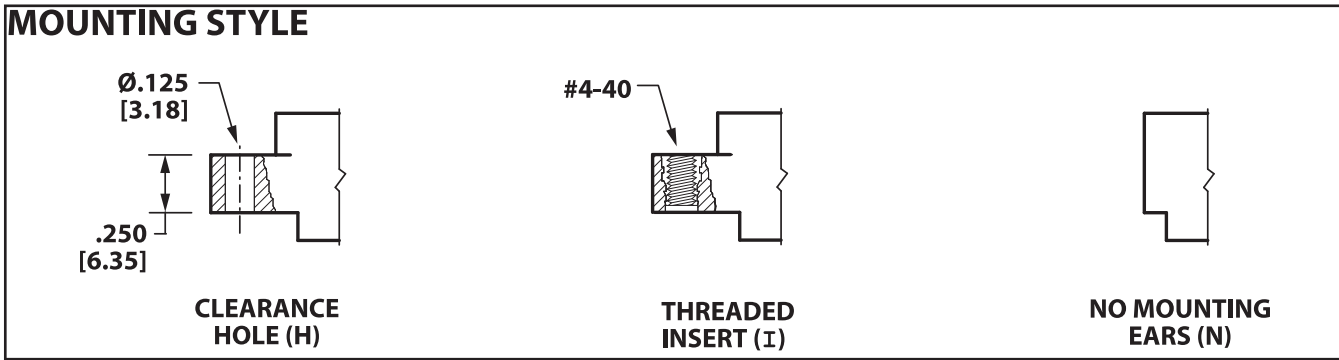
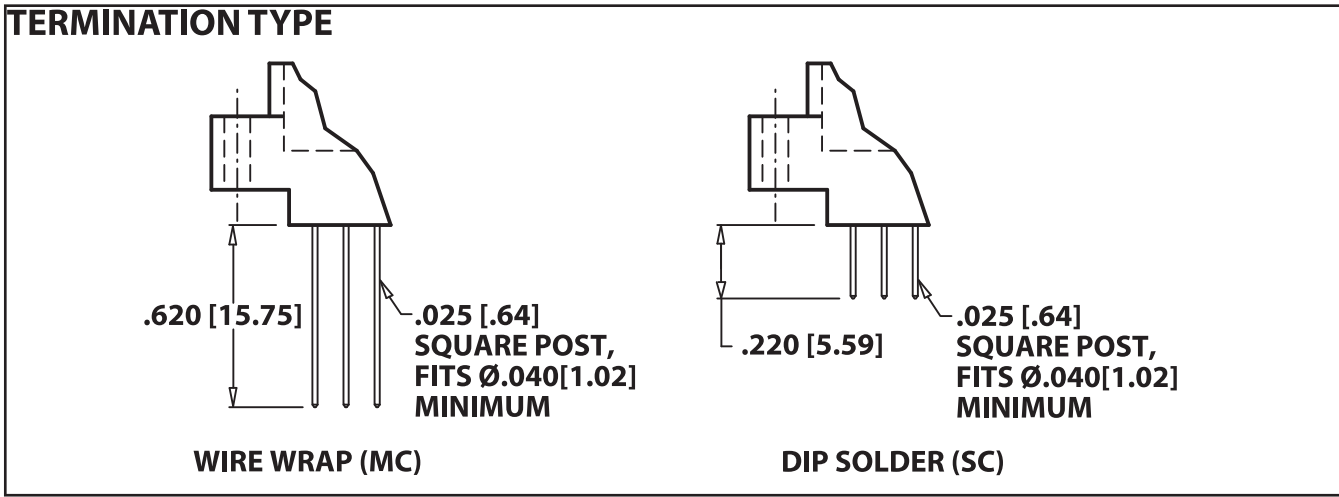
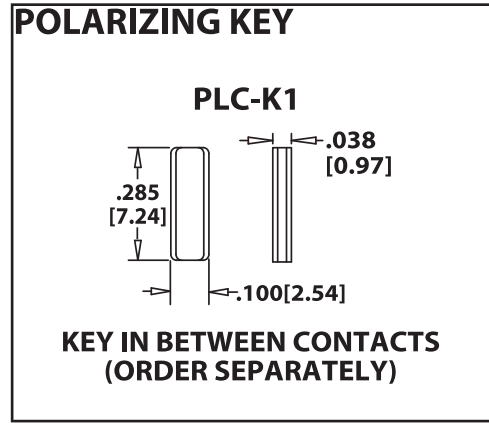
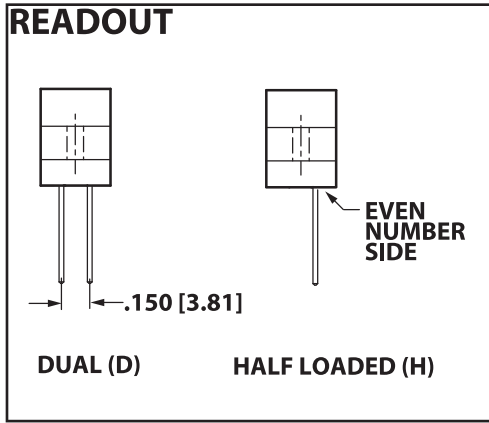
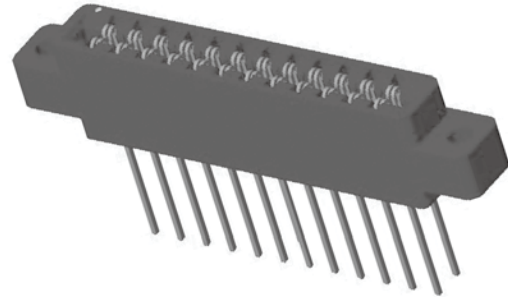

Sullins Female Card Edge



**.150" [3.81 mm] Contact Centers, .550" [13.97 mm] Insulator Height  
Dip Solder/Wire Wrap**

**PART NUMBER OPTIONS**

**E B J 26 D MC H - Sxxx**

**MATERIALS (Insulator/Contact)**  
 E = PBT/Phosphor Bronze (Standard)  
 R = PPS/Phosphor Bronze  
 G = PA9T/Phosphor Bronze  
 (Consult Factory for Other Materials)

**CONTACT FINISH - RoHS Compliant**  
**All platings are Lead Free and have .000050" Nickel underplate**  
**Contact Surface Termination**  
 B = .000010" Gold .000100" Pure Tin, Matte  
 C = .000030" Gold .000100" Pure Tin, Matte

**CONTACT CENTERS**  
 J = .150" [3.81mm]

**NUMBER OF CONTACT POSITIONS**  
 See Chart Below

**MODIFICATION CODE (Consult Factory)**  
 OMIT FOR STANDARD

**MOUNTING STYLE (Opposite Page)**  
 H = Clearance Holes  
 I = Threaded Inserts  
 N = No Mounting

**TERMINATION TYPE (Opposite Page)**  
**Hairpin Bellows**  
 MC = .025" [.64mm] Square Wire Wrap  
 SC = .025" [.64mm] Square Dip Solder

**READOUT (Opposite Page)**  
 D = Dual  
 H = Half Loaded

Sullins Female Card Edge

**DIMENSIONS** Dimensions in [ ] are in millimeters, all others are in inches.

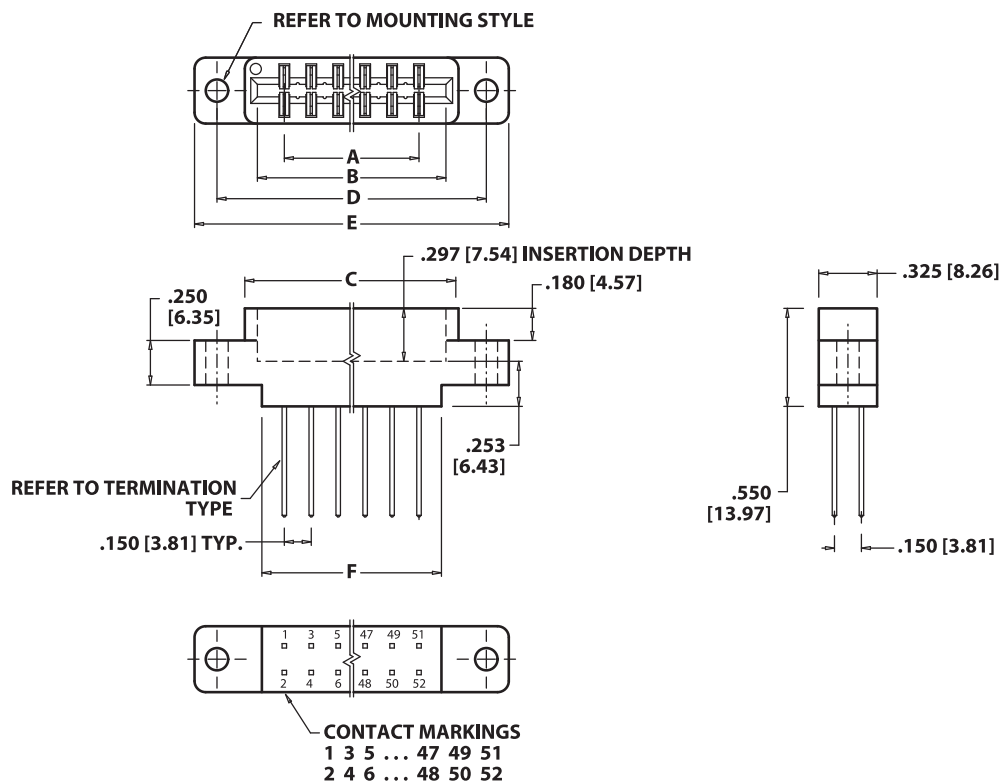

Tolerances with PPS Insulator Material may vary slightly due to shrinkage differential: Consult Factory.

POSITIONS/ CONTACTS	INCHES						[MILLIMETERS]					
	A±.008	B±.008	C±.015	D±.010	E±.020	F±.015	A±0.20	B±0.20	C±0.38	D±0.25	E±0.51	F±0.38
12/24	1.650	1.950	2.090	2.400	2.650	2.000	41.91	49.53	53.09	60.96	67.31	50.80
18/36*	2.550	2.850	2.990	3.300	3.550	2.800	64.77	72.39	75.95	83.82	90.17	71.12
22/44*	3.150	3.450	3.590	3.900	4.150	3.400	80.01	87.63	91.19	99.06	105.41	86.36
26/52	3.750	4.050	4.190	4.500	4.750	4.000	95.25	102.87	106.43	114.30	120.65	101.60
28/56*	4.050	4.350	4.490	4.800	5.050	4.300	102.87	110.49	114.05	121.92	128.27	109.22

\* Consult Factory For Availability.



# Female Card Edge

**.156" [3.96 mm] Contact Centers, .431" [10.95 mm] Insulator Height**  
**Dip Solder/Eyelet/Right Angle**

## SPECIFICATIONS

- Accommodates .062" ± .008" [1.57 ± .20] PC board
- Molded-in key available
- 3 amp current rating  
(for 5 amp application, consult factory)
- 30 milli ohm maximum at rated current
- UL Flammability Rating: 94V-0

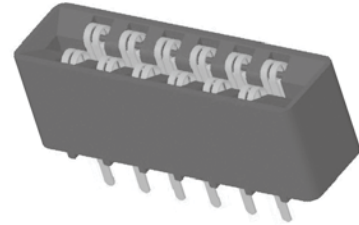

Sullins Female Card Edge

## READOUT

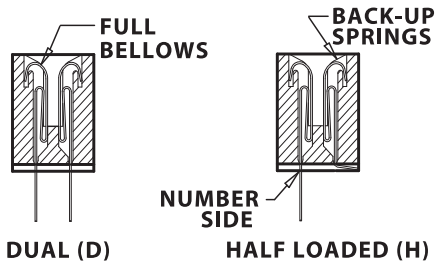

## POLARIZING KEY

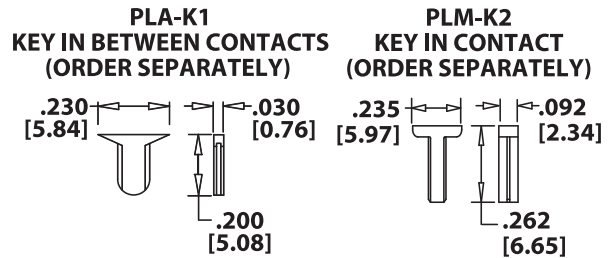

CONSULT FACTORY FOR MOLDED-IN KEY

## TERMINATION TYPE

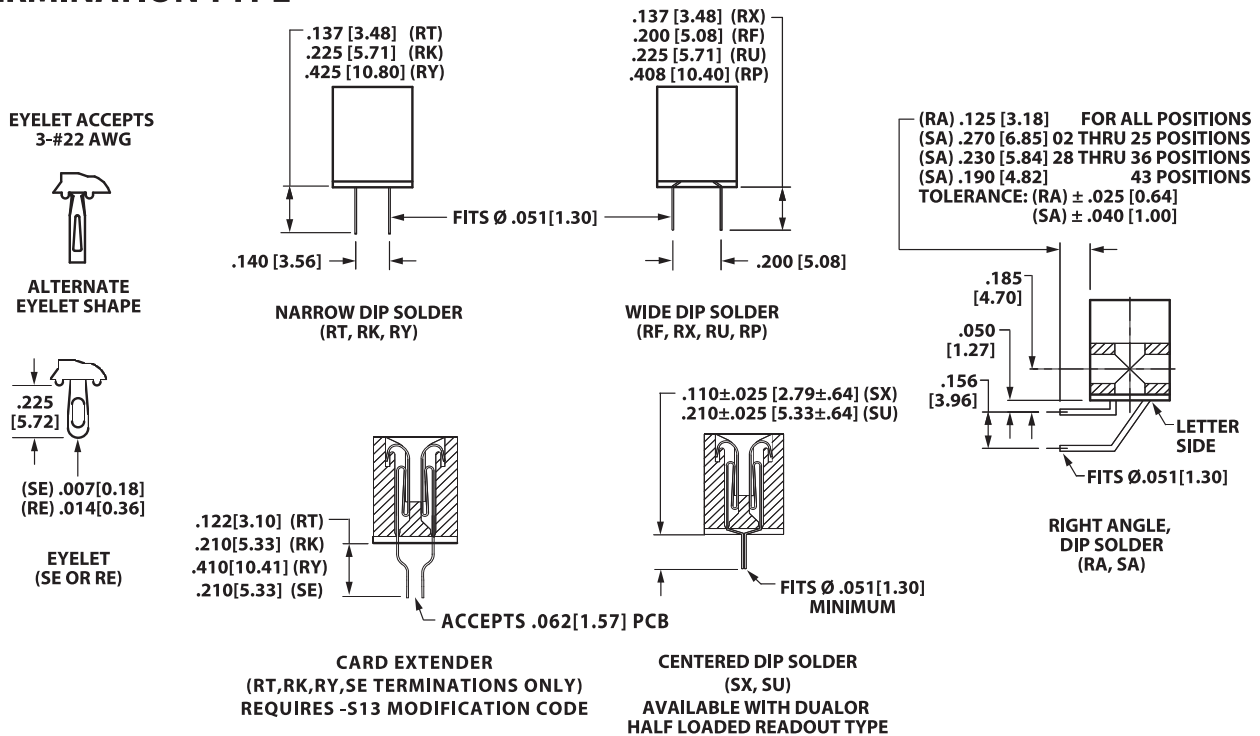

## MOUNTING STYLE

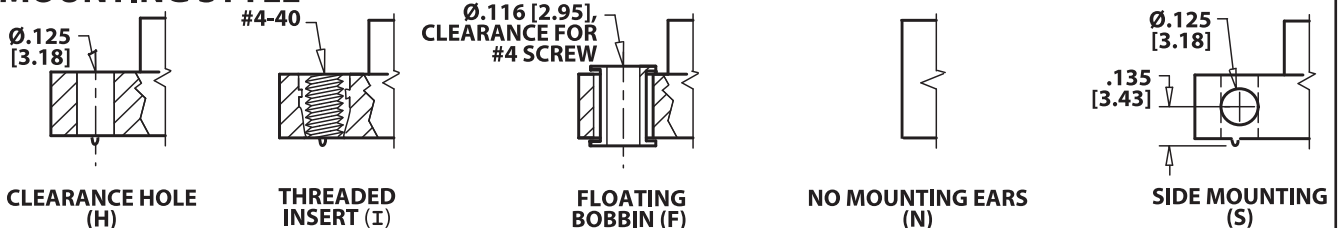



**.156" [3.96 mm] Contact Centers, .431" [10.95 mm] Insulator Height  
Dip Solder/Eyelet/Right Angle**

**PART NUMBER OPTIONS**

**MATERIALS (Insulator/Contact)**

- E = PBT/Phosphor Bronze (Standard)
- R = PPS/Phosphor Bronze
- G = PA9T/Phosphor bronze
- H = PBT/Beryllium Copper
- A = PPS/Beryllium Copper
- J = PA9T/Beryllium Copper
- \*F = PPS/Spinodal (Overall Gold Plating Only)  
Consult Factory for Special Soldering Guidelines
- \*C = PPS/Beryllium Nickel (Overall Gold Plating Only)
- \*W = PEEK/Beryllium Nickel (Overall Gold Plating Only)  
\*Consult Factory for availability.

**CONTACT FINISH - RoHS Compliant**

All platings are Lead Free and have .000050" Nickel underplate

	Contact Surface	Termination
B =	.000010" Gold	.000100" Pure Tin, Matte
C =	.000030" Gold	.000100" Pure Tin, Matte
G =	.000010" Gold	.000005" Gold
Y =	.000030" Gold	.000005" Gold
	Contact Surface	Overall Plating
S =	.000010" Gold	.000010" Gold
M =	.000030" Gold	.000010" Gold
E =	.000100" Pure Tin, Matte	.000100" Pure Tin, Matte

**CONTACT CENTERS**

M = .156" [3.96mm]

**NUMBER OF CONTACT POSITIONS**

See Chart Below

**E B M 43 D RK H - Sxxx**

**MODIFICATION CODE (Consult Factory)**  
OMIT FOR STANDARD

-S13 = Card Extender Accepts .062" [1.57] PCB  
(RT, RK, RY, SE Terminations Only)

**MOUNTING STYLE (Opposite Page)**

- H = .125" [3.18mm] Clearance Holes
- N = No Mounting
- S = Side Mounting
- I = Threaded Insert
- F = Floating Bobbin

**TERMINATION TYPE (Opposite Page)**

- RA = .125" Right Angle Dip Solder
- SA = Long Right Angle Dip Solder
- RT = .140" x .137" Dip Solder
- RK = .140" x .225" Dip Solder
- RY = .140" x .425" Dip Solder
- RX = .200" x .137" Dip Solder
- RF = .200" x .200" Dip Solder
- RU = .200" x .225" Dip Solder
- RP = .200" x .408" Dip Solder
- SX = .110" [2.79mm] Centered Dip Solder
- SU = .210" [5.33mm] Centered Dip Solder
- SE = .007" [.18mm] Thick Eyelet
- RE = .014" [.36mm] Thick Eyelet

**READOUT (Opposite Page)**

- D = Dual
- D = Dual Row/ Crimp to Center for  
Single Readout (SX, SU Termination Only)
- H = Half Loaded

**DIMENSIONS**

Dimensions in [ ] are in millimeters, all others are in inches.

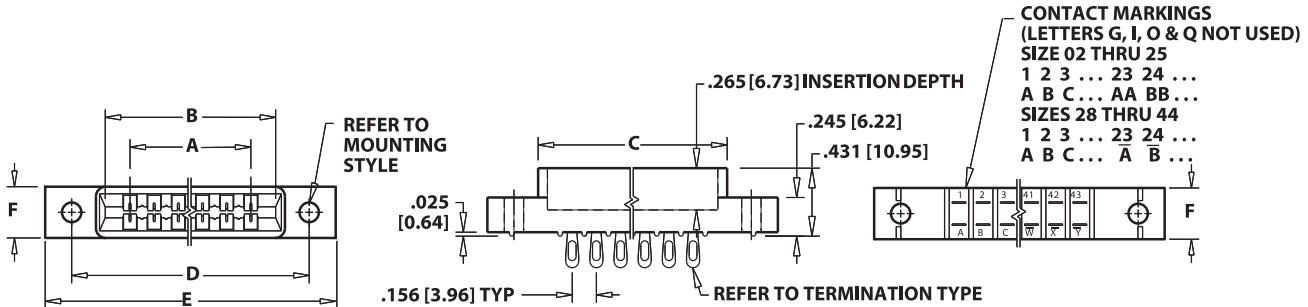

Tolerances with PPS Insulator Material may vary slightly due to shrinkage differential; Consult Factory.

POSITIONS/ CONTACTS	INCHES					F±.005	[MILLIMETERS]					F±0.13	
	A±.008	B±.008	C±.015	D±.010	E MAX		A±0.20	B±0.20	C±0.38	D±0.25	E MAX		
02/04	0.156	0.476	0.596	'N' MOUNTING		0.325	3.96	12.09	15.14	'N' MOUNTING		8.26	
03/06	0.312	0.632	0.752	'N' MOUNTING			7.92	16.05	19.10	'N' MOUNTING			
04/08	0.468	0.788	0.908	'N' MOUNTING			11.89	20.02	23.06	'N' MOUNTING			
06/12	0.780	1.100	1.220	1.533	1.902		19.81	27.94	30.99	38.94	48.31		
07/14	0.936	1.256	1.376	1.689	2.058		23.77	31.90	34.95	42.90	52.27		
08/16	1.092	1.412	1.532	1.845	2.214		27.74	35.86	38.91	46.86	56.24		
10/20	1.404	1.724	1.844	2.157	2.526		35.66	43.79	46.84	54.79	64.16		
11/22	1.560	1.880	2.000	2.313	2.682		39.62	47.75	50.80	58.75	68.12		
12/24	1.716	2.036	2.156	2.469	2.838		43.59	51.71	54.76	62.71	72.09		
15/30	2.184	2.504	2.624	2.937	3.306		55.47	63.60	66.65	74.60	83.97		
18/36	2.652	2.972	3.092	3.405	3.774		67.36	75.49	78.54	86.49	95.86		
22/44	3.276	3.596	3.716	4.029	4.398		83.21	91.34	94.39	102.34	111.71		
24/48	3.588	3.908	4.028	4.341	4.710		91.14	99.26	102.31	110.26	119.63		
25/50	3.744	4.064	4.184	4.497	4.866		95.10	103.23	106.27	114.22	123.60		
28/56	4.212	4.532	4.652	4.965	5.334		106.98	115.11	118.16	126.11	135.48		11.13
36/72	5.460	5.780	5.900	6.213	6.582		138.68	146.81	149.86	157.81	167.18		
43/86	6.552	6.872	6.992	7.305	7.674	166.42	174.55	177.60	185.55	194.92	12.70		
44/88	6.708	7.028	7.148	7.461	7.830	170.38	178.51	181.56	189.51	198.88			



# Female Card Edge

**.156" [3.96 mm] Contact Centers, .431" [10.95 mm] Insulator Height**  
**Special Body Configuration Dip Solder/Eyelet/Right Angle**

## SPECIFICATIONS

- Accommodates .062" ± .008"  
[1.57 ± .20] PC board
- Molded-in key available
- 3 amp current rating  
(for 5 amp application, consult factory)
- 30 milli ohm maximum at rated current
- UL Flammability Rating: 94V-0



Sullins Female Card Edge

## READOUT

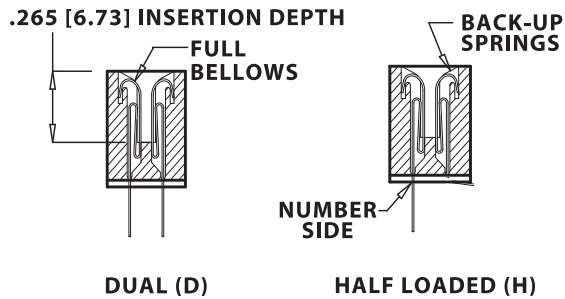

## POLARIZING KEY

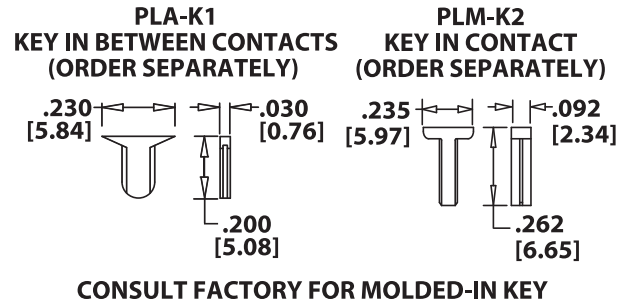

## TERMINATION TYPE

**EYELET ACCEPTS**  
3-#22 AWG

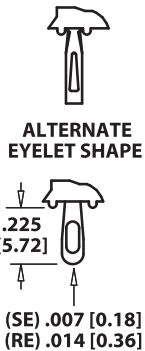

**(RA) .125 [3.18] FOR ALL POSITIONS**  
**(SA) .270 [6.85] 02 THRU 25 POSITIONS**  
**(SA) .230 [5.84] 28 THRU 36 POSITIONS**  
**(SA) .190 [4.82] 43 POSITIONS**  
**TOLERANCE: (RA) ±.025 [0.64]**  
**(SA) ±.040 [1.00]**

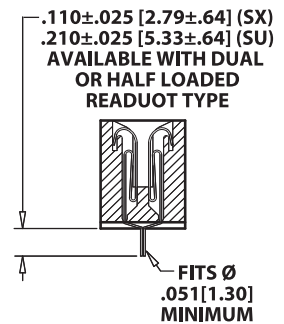
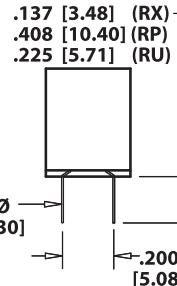
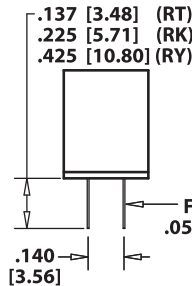
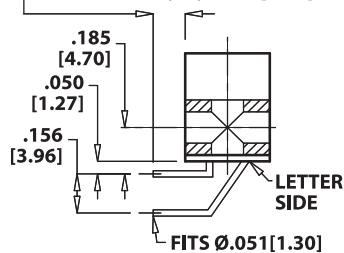

## MOUNTING STYLE

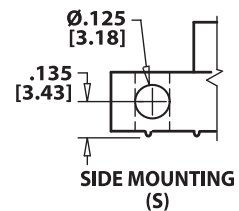
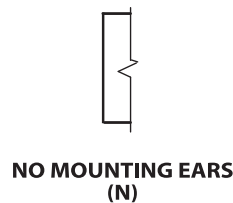
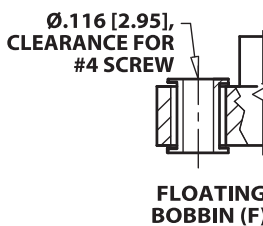
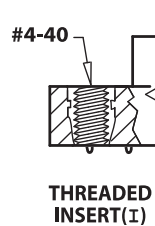
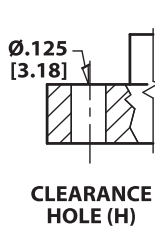



**.156" [3.96 mm] Contact Centers, .431" [10.95 mm] Insulator Height  
Special Body Configuration Dip Solder/Eyelet/Right Angle**

**PART NUMBER OPTIONS**

**E B M 43 D R T H - S37**

**MATERIALS (Insulator/Contact)**

- E = PBT/Phosphor Bronze (Standard)
- R = PPS/Phosphor Bronze
- G = PA9T/Phosphor bronze
- H = PBT/Beryllium Copper
- A = PPS/Beryllium Copper
- J = PA9T/Beryllium Copper
- \*F = PPS/Spinodal (Overall Gold Plating Only)  
Consult Factory for Special Soldering Guidelines
- \*C = PPS/Beryllium Nickel (Overall Gold Plating Only)
- \*W = PEEK/Beryllium Nickel (Overall Gold Plating Only)  
\*Consult Factory for availability.

**CONTACT FINISH - RoHS Compliant**  
All platings are Lead Free and have .000050" Nickel underplate

Contact Surface	Termination
B = .000010" Gold	.000100" Pure Tin, Matte
C = .000030" Gold	.000100" Pure Tin, Matte
G = .000010" Gold	.000005" Gold
Y = .000030" Gold	.000005" Gold
Contact Surface	Overall Plating
S = .000010" Gold	.000010" Gold
M = .000030" Gold	.000010" Gold
E = .000100" Pure Tin, Matte	.000100" Pure Tin, Matte

**CONTACT CENTERS**  
M = .156" [3.96mm]

**NUMBER OF CONTACT POSITIONS**  
28 (14/14), 36 or 43

**MODIFICATION CODE (Consult Factory)**  
-S37 = Reverse Contact ID & Shorter Card Slot Length  
-S92 = Center Barrier Molded in Card Slot

**MOUNTING STYLE (Opposite Page)**  
H = .125" [3.18mm] Clearance Holes  
N = No Mounting  
S = Side Mounting  
I = Threaded Insert  
F = Floating Bobbin

**TERMINATION TYPE (Opposite Page)**  
RA = .125" Right Angle Dip Solder  
SA = Long Right Angle Dip Solder  
RT = .140" x .137" Dip Solder  
RK = .140" x .225" Dip Solder  
RY = .140" x .425" Dip Solder  
RX = .200" x .137" Dip Solder  
RU = .200" x .225" Dip Solder  
RP = .200" x .408" Dip Solder  
SX = .110" [2.79mm] Centered Dip Solder  
SU = .210" [5.33mm] Centered Dip Solder  
SE = .007" [0.18mm] Thick Eyelet  
RE = .014" [0.36mm] Thick Eyelet

**READOUT (Opposite Page)**  
D = Dual  
D = Dual Row/ Crimp to Center for Single Readout (SX, SU Termination Only)  
H = Half Loaded

Sullins Female Card Edge

**DIMENSIONS** Dimensions in [ ] are in millimeters, all others are in inches.

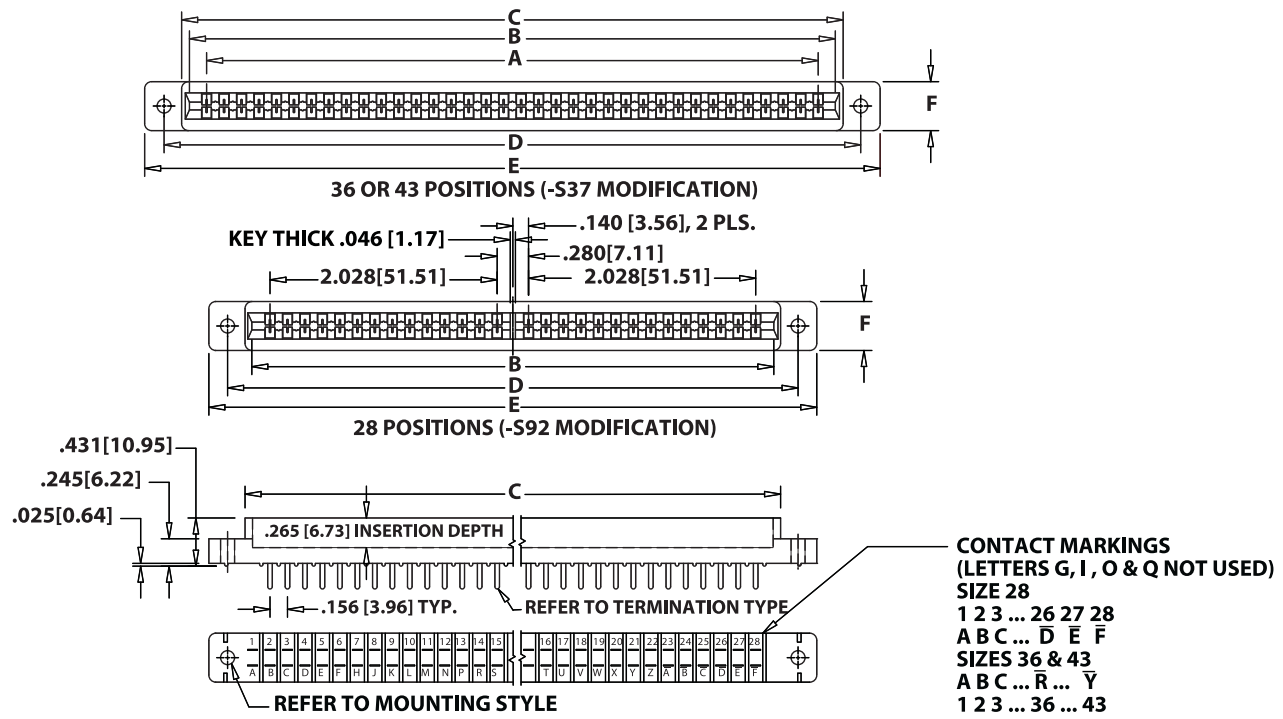

Tolerances with PPS Insulator Material may vary slightly due to shrinkage differential; Consult Factory.

POSITIONS/ CONTACTS	INCHES						[MILLIMETERS]						CENTER BARRIER
	A±.008	B±.008	C±.015	D±.010	E MAX	F±.005	A±0.20	B±0.20	C±0.38	D±0.25	E MAX	F±0.13	
28/56		4.660	4.780	5.093	5.427	0.438		118.36	121.41	129.36	137.85	11.13	YES
36/72	5.460	5.766	5.906	6.219	6.566	0.438	138.68	146.46	150.01	157.96	166.78	11.13	NO
43/86	6.552	6.810	7.000	7.302	7.643	0.500	166.42	172.97	177.80	185.47	194.13	12.70	NO



**.156" [3.96 mm] Contact Centers, .610" [15.49 mm] Insulator Height**  
**Dip Solder/Wire Wrap/Right Angle/Card Extender**

**SPECIFICATIONS**

- Accommodates .062" ± .008" [1.57 ± .20] PC board (See next 2 pages for .093" ± .008" [2.36 ± .20] and .125" ± .008" [3.18 ± .20] boards)
- PBT, PPS or PA9T insulator
- Molded-in key available
- 3 amp current rating
- 30 milli ohm maximum at rated current
- UL Flammability Rating: 94V-0

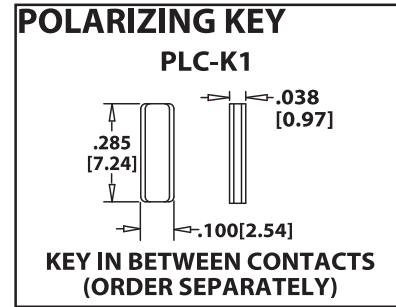
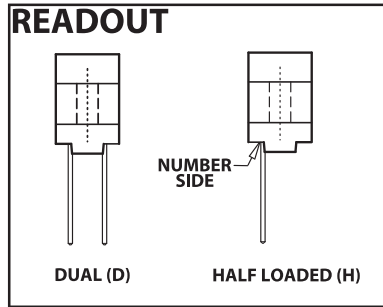
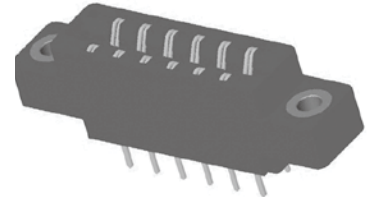

**TERMINATION TYPE**

HAIRPIN BELLOWS	TERMINATION TYPE	POST CROSS SECTION K	POST LENGTH L .025 [.64]	FITS MIN. HOLE SIZE
CW	DIP SOLDER	.015 x .025 [.38 x .64]	.125 [3.18]	.035 [0.89]
CT	DIP SOLDER	.015 x .025 [.38 x .64]	.170 [4.32]	.035 [0.89]
CS	DIP SOLDER	.025 [.64] SQUARE	.160 [4.06]	.040 [1.02]
CM	WIRE WRAP	.025 [.64] SQUARE	.560 [14.20]	.040 [1.02]
CA	RIGHT ANGLE	.025 [.64] SQUARE	.100 [2.54]	.043 [1.09]
CB	RIGHT ANGLE	.025 [.64] SQUARE	.180 [4.57]	.043 [1.09]
CC	RIGHT ANGLE	.025 [.64] SQUARE	.250 [6.35]	.043 [1.09]

**HAIRPIN BELLOWS**

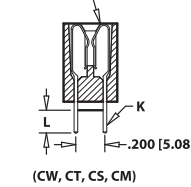

**RIGHT ANGLE**

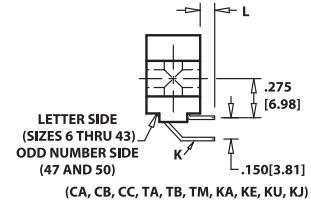

LOOP BELLOWS	TERMINATION TYPE	POST CROSS SECTION K	POST LENGTH L .025 [.64]	FITS MIN. HOLE SIZE
TK,CK	DIP SOLDER	.025 [.64] ROUND	.190 [4.83]	.033 [0.84]
RS	DIP SOLDER	.025 [.64] SQUARE	.190 [4.83]	.040 [1.02]
RM	WIRE WRAP	.025 [.64] SQUARE	.560 [14.20]	.040 [1.02]
TA	RIGHT ANGLE	.025 [.64] SQUARE	.100 [2.54]	.043 [1.09]
TB	RIGHT ANGLE	.025 [.64] SQUARE	.180 [4.57]	.043 [1.09]
TM	RIGHT ANGLE	.025 [.64] SQUARE	.250 [6.35]	.043 [1.09]

**LOOP BELLOWS**

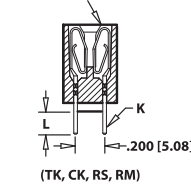

**HAIRPIN or LOOP CARD EXTENDER**

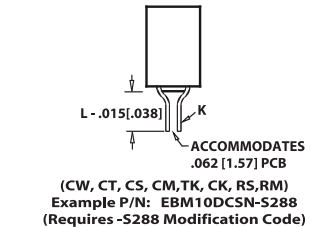

CANTILEVER	TERMINATION TYPE	POST CROSS SECTION K	POST LENGTH L .025 [.64]	FITS MIN. HOLE SIZE
KS	DIP SOLDER	.025 [.64] SQUARE	.190 [4.83]	.040 [1.02]
KD	DIP SOLDER	.025 [.64] SQUARE	.160 [4.06]	.043 [1.09]
KM	WIRE WRAP	.025 [.64] SQUARE	.560 [14.20]	.040 [1.02]
*KA	RIGHT ANGLE	.025 [.64] SQUARE	.100 [2.54]	.043 [1.09]
*KE	RIGHT ANGLE	.025 [.64] SQUARE	.180 [4.57]	.043 [1.09]
*KU	RIGHT ANGLE	.025 [.64] SQUARE	.250 [6.35]	.043 [1.09]
*KJ	RIGHT ANGLE	.025 [.64] SQUARE	.500 [12.70]	.043 [1.09]
*KR	CARD EXTENDER	.025 [.64] SQUARE	.235 [5.97]	N/A
*KN	CARD EXTENDER	.025 [.64] SQUARE	.605 [15.37]	N/A

**CANTILEVER**

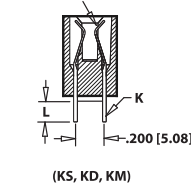

**CANTILEVER CARD EXTENDER**

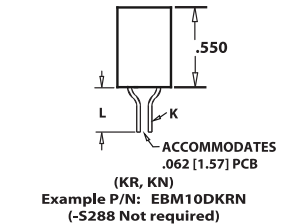

\* KA, KE, KJ, KR, KN have no standoffs, unless requested.

**MOUNTING STYLE**

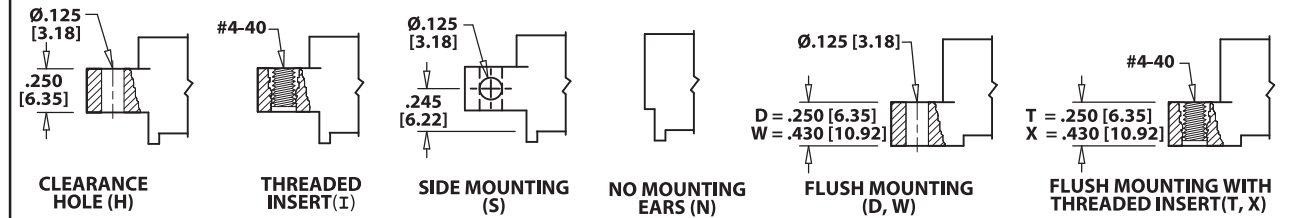



**.156" [3.96 mm] Contact Centers, .610" [15.49 mm] Insulator Height  
Dip Solder/Wire Wrap/Right Angle/Card Extender**

**PART NUMBER OPTIONS**

**MATERIALS (Insulator/Contact)**  
 E = PBT/Phosphor Bronze (Standard)  
 R = PPS/Phosphor Bronze  
 G = PA9T/Phosphor Bronze  
 A = PPS/Beryllium Copper  
 J = PA9T/Beryllium Copper  
 (Consult Factory For Other Materials)

**CONTACT FINISH - RoHS Compliant**  
**All platings are Lead Free and have .000050" Nickel underplate**

<b>Contact Surface</b>	<b>Termination</b>
B = .000010" Gold	.000100" Pure Tin, Matte
C = .000030" Gold	.000100" Pure Tin, Matte
G = .000010" Gold	.000005" Gold
Y = .000030" Gold	.000005" Gold
<b>Contact Surface</b>	<b>Overall Plating</b>
S = .000010" Gold	.000010" Gold
M = .000030" Gold	.000010" Gold
E = .000100" Pure Tin, Matte	.000100" Pure Tin, Matte

**CONTACT CENTERS**  
 M = .156" [3.96mm]

**NUMBER OF CONTACT POSITIONS**  
 See Chart Below

**READOUT (Opposite Page)**  
 D = Dual  
 H = Half Loaded

**E B M 43 D CM H - Sxxx**

**MODIFICATION CODE (Consult Factory)**  
 OMIT FOR STANDARD  
 -S189 = .200" [5.08mm] Row to Row on Right Angle  
 -S288\* = Card Extender Accepts .062" [1.57] PCB  
 \* Not Required on KR or KN Terminations

**MOUNTING STYLE (Opposite Page)**  
 H = Clearance Holes  
 I = Threaded Inserts  
 S = Side Mounting  
 N = No Mounting  
 D, W = Flush Mounting  
 T, X = Flush Mounting With Threaded Inserts

**TERMINATION TYPE (Opposite Page)**

**Hairpin Bellows - Available with B or C plating and Phosphor Bronze Only**  
 CS = .025" [.64mm] Square Dip Solder  
 CM = .025" [.64mm] Square Wire Wrap  
 CA, CB, CC = .025" [.64mm] Square Right Angle  
 CW, CT = .015" x .025" [.38 x .64] Dip Solder

**Loop Bellows**  
 RS = .025" [0.64mm] Square Dip Solder  
 CK, TK = .025" [0.64mm] Round Dip Solder  
 RM = .025" [0.64mm] Square Wire Wrap  
 TA, TB, TM = .025" [.64mm] Square Right Angle

**Cantilever Bellows - Available in Y, B, or C Contact Finish Only**  
**Not Available with R or A Materials**  
 KS, KD = .025" [.64mm] Square Dip Solder  
 KM = .025" [.64mm] Square Wire Wrap  
 KA, KE, KU, KJ = .025" [.64mm] Square Right Angle  
 KR, KN = .025" [.64mm] Square Card Extender

Sullins Female Card Edge

**DIMENSIONS**

Dimensions in [ ] are in millimeters, all others are in inches.

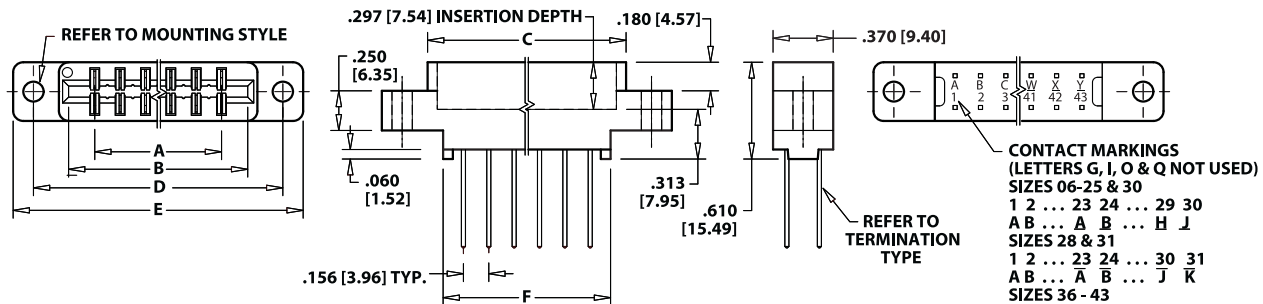

Tolerances with PPS Insulator Material may vary slightly due to shrinkage differential: Consult Factory.

POSITIONS/ CONTACTS	INCHES						[MILLIMETERS]					
	A±.008	B±.008	C±.015	D±.010	E±.020	F±.015	A±0.20	B±0.20	C±0.38	D±0.25	E±0.51	F±0.38
06/12	0.780	1.102	1.221	1.534	1.784	1.030	19.81	27.99	31.01	38.96	45.31	26.16
08/16	1.092	1.414	1.533	1.846	2.096	1.342	27.74	35.92	38.94	46.89	53.24	34.09
10/20	1.404	1.726	1.845	2.158	2.408	1.654	35.66	43.84	46.86	54.81	61.16	42.01
12/24	1.716	2.038	2.157	2.470	2.720	1.966	43.59	51.77	54.79	62.74	69.09	49.94
15/30	2.184	2.506	2.625	2.938	3.188	2.434	55.47	63.65	66.68	74.63	80.98	61.82
18/36	2.652	2.974	3.093	3.406	3.656	2.902	67.36	75.54	78.56	86.51	92.86	73.71
20/40*	2.964	3.286	3.405	3.718	3.968	3.214	75.29	83.46	86.49	94.44	100.79	81.64
22/44	3.276	3.598	3.717	4.030	4.280	3.526	83.21	91.39	94.41	102.36	108.71	89.56
24/48	3.588	3.910	4.029	4.342	4.592	3.838	91.14	99.31	102.34	110.29	116.64	97.49
25/50	3.744	4.066	4.185	4.498	4.748	3.994	95.10	103.28	106.30	114.25	120.60	101.45
28/56	4.212	4.534	4.653	4.966	5.216	4.462	106.98	115.16	118.19	126.14	132.49	113.33
30/60	4.524	4.846	4.965	5.278	5.528	4.774	114.91	123.09	126.11	134.06	140.41	121.26
31/62	4.680	5.002	5.121	5.434	5.684	4.930	118.87	127.05	130.07	138.02	144.37	125.22
36/72	5.460	5.782	5.901	6.214	6.464	5.710	138.68	146.86	149.89	157.84	164.19	145.03
40/80	6.084	6.406	6.525	6.838	7.088	6.334	154.53	162.71	165.74	173.69	180.04	160.88
43/86	6.552	6.874	6.993	7.306	7.556	6.802	166.42	174.60	177.62	185.57	191.92	172.77
47/94	7.176	7.498	7.617	7.930	8.180	7.426	182.27	190.45	193.47	201.42	207.77	188.62
50/100	7.644	7.966	8.085	8.398	8.648	7.894	194.16	202.34	205.36	213.31	219.66	200.51

\* Consult Factory for availability.



# Female Card Edge

**.156" [3.96 mm] Contact Centers, .610" [15.49 mm] Insulator Height**  
**Dip Solder/Wire Wrap/Right Angle for .093" [2.36] or .125" [3.18] Mating PCB**

## SPECIFICATIONS

- Accommodates  $.093" \pm .008"$  [2.36  $\pm$  .20] or  $.125" \pm .008"$  [3.18  $\pm$  .20] mating PCB (Consult factory for  $.031" \pm .008"$  [.79  $\pm$  .20] boards)
- PBT, PPS or PA9T insulator
- Molded-in key available
- 3 amp current rating
- 30 milli ohm maximum at rated current
- UL Flammability Rating: 94V-0

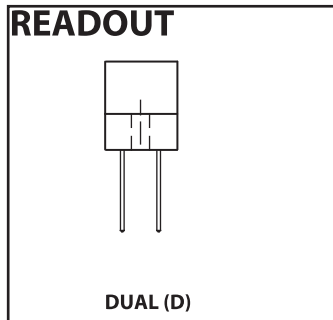
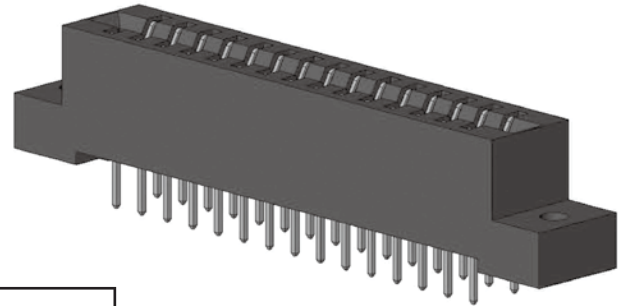

## TERMINATION TYPE

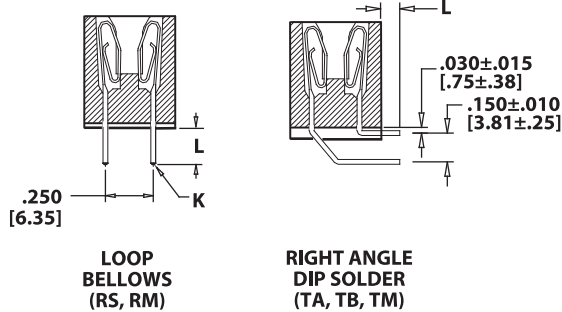

TERMINATION TYPE	POST CROSS SECTION (K)	POST LENGTH L $\pm .025$ [.64]	FITS MIN. HOLE SIZE
<b>RS</b> Dip Solder	.025 [.64] SQUARE	.190 [4.83]	.040 [1.02]
<b>RM</b> Wire Wrap	.025 [.64] SQUARE	.560 [14.20]	.040 [1.02]
<b>TA</b> Right Angle	.025 [.64] SQUARE	.100 [2.54]	.043 [1.09]
<b>TB</b> Right Angle	.025 [.64] SQUARE	.180 [4.57]	.043 [1.09]
<b>TM</b> Right Angle	.025 [.64] SQUARE	.250 [6.35]	.043 [1.09]

## PCB LAYOUT

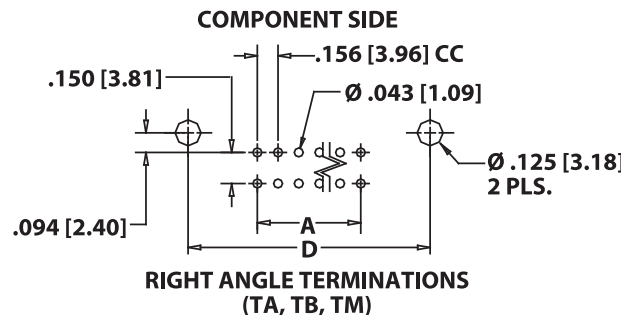
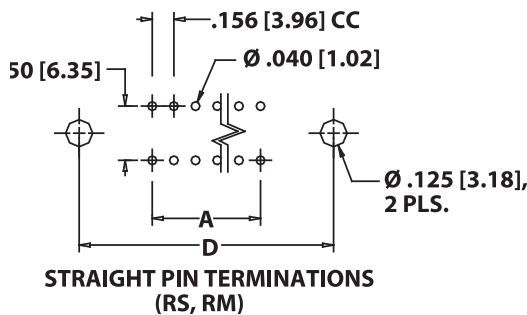

## MOUNTING STYLE

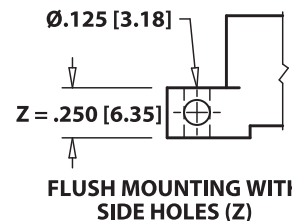
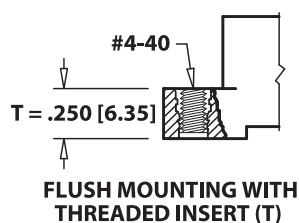
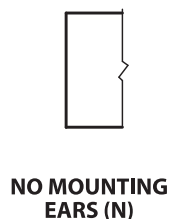
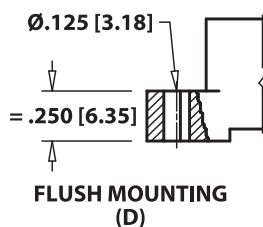



**.156" [3.96 mm] Contact Centers, .610" [15.49 mm] Insulator Height**  
**Dip Solder/Wire Wrap/Right Angle for .093" [2.36] or .125" [3.18] Mating PCB**

**PART NUMBER OPTIONS**

**MATERIALS (Insulator/Contact)**

- E = PBT/Phosphor Bronze (Standard)
- R = PPS/Phosphor Bronze
- G = PA9T/Phosphor Bronze
- A = PPS/Beryllium Copper
- J = PA9T/Beryllium Copper
- (Consult Factory For Other Materials)

**CONTACT FINISH - RoHS Compliant**

All platings are Lead Free and have .000050" Nickel underplate

	Contact Surface	Termination
B =	.000010" Gold	.000100" Pure Tin, Matte
C =	.000030" Gold	.000100" Pure Tin, Matte
G =	.000010" Gold	.000005" Gold
Y =	.000030" Gold	.000005" Gold
	Contact Surface	Overall Plating
S =	.000010" Gold	.000010" Gold
M =	.000030" Gold	.000010" Gold
E =	.000100" Pure Tin, Matte	.000100" Pure Tin, Matte

**CONTACT CENTERS**

M = .156" [3.96mm]

**E B M 43 D RM D - S273**

**MODIFICATION CODE (Consult Factory)**

- S273 = FOR .093" ± .008" [2.36 ± .20] THICK MATING PCB
- S664 = FOR .125" ± .008" [3.18 ± .20] THICK MATING PCB

**MOUNTING STYLE (Opposite Page)**

- N = No Mounting
- D = Flush Mounting
- T = Flush Mounting With Threaded Inserts
- Z = Flush Mounting With Side Holes

**TERMINATION TYPE (Opposite Page)**

- RS = .025" [.64mm] Square Dip Solder
- RM = .025" [.64mm] Square Wire Wrap
- TA, TB, TM = .025" [.64mm] Square Right Angle

**READOUT (Opposite Page)**

- D = Dual

**NUMBER OF CONTACT POSITIONS**

See Chart Below

**DIMENSIONS**

Dimensions in [ ] are in millimeters, all others are in inches.

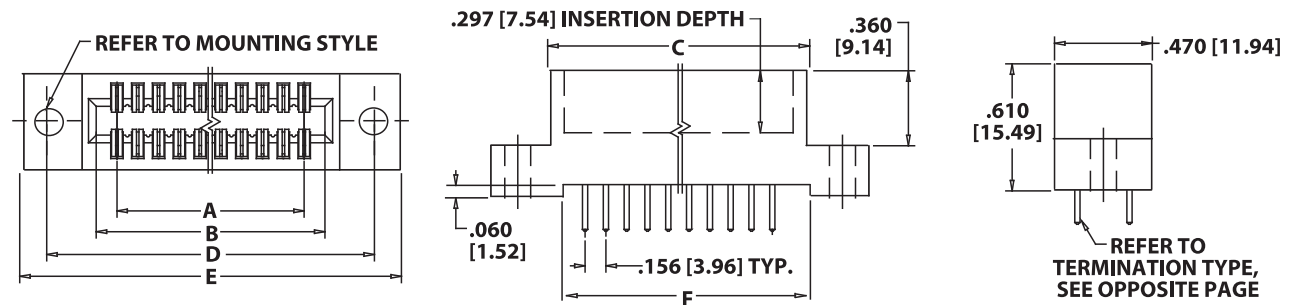

Tolerances with PPS Insulator Material may vary slightly due to shrinkage differential; Consult Factory.

POSITIONS/ CONTACTS	INCHES						[MILLIMETERS]					
	A±.008	B±.008	C±.015	D±.010	E±.020	F±.015	A±0.20	B±0.20	C±0.38	D±0.25	E±0.51	F±0.38
06/12*	0.780	1.102	1.221	1.534	1.784	1.104	19.81	27.99	31.01	38.96	45.31	28.04
08/16*	1.092	1.414	1.533	1.846	2.096	1.416	27.74	35.92	38.94	46.89	53.24	35.97
10/20	1.404	1.726	1.845	2.158	2.408	1.728	35.66	43.84	46.86	54.81	61.16	43.89
12/24	1.716	2.038	2.157	2.470	2.720	2.040	43.59	51.77	54.79	62.74	69.09	51.82
15/30	2.184	2.506	2.625	2.938	3.188	2.508	55.47	63.65	66.68	74.63	80.98	63.70
18/36*	2.652	2.974	3.093	3.406	3.656	2.976	67.36	75.54	78.56	86.51	92.86	75.59
20/40*	2.964	3.286	3.405	3.718	3.968	3.288	75.29	83.46	86.49	94.44	100.79	83.52
22/44*	3.276	3.598	3.717	4.030	4.280	3.600	83.21	91.39	94.41	102.36	108.71	91.44
24/48*	3.588	3.910	4.029	4.342	4.592	3.912	91.14	99.31	102.34	110.29	116.64	99.37
25/50*	3.744	4.066	4.185	4.498	4.748	4.068	95.10	103.28	106.30	114.25	120.60	103.33
28/56*	4.212	4.534	4.653	4.966	5.216	4.536	106.98	115.16	118.19	126.14	132.49	115.21
30/60*	4.524	4.846	4.965	5.278	5.528	4.848	114.91	123.09	126.11	134.06	140.41	123.14
31/62*	4.680	5.002	5.121	5.434	5.684	5.004	118.87	127.05	130.07	138.02	144.37	127.10
32/64	4.836	5.158	5.277	5.590	5.840	5.160	122.83	131.01	134.04	141.99	148.34	131.06
36/72	5.460	5.782	5.901	6.214	6.464	5.784	138.68	146.86	149.89	157.84	164.19	146.91
40/80*	6.084	6.406	6.525	6.838	7.088	6.408	154.53	162.71	165.74	173.69	180.04	162.76
43/86*	6.552	6.874	6.993	7.306	7.556	6.876	166.42	174.60	177.62	185.57	191.92	174.65

\* Consult Factory For Availability.



# Female Card Edge

**.156" [3.96 mm] Contact Centers, .720" [18.29 mm] Insulator Height  
.045" [1.14 mm] square / .031" [.79 mm] x .062" [1.57 mm] Wire Wrap**

## SPECIFICATIONS

- Accommodates .062" ± .008" [1.57 ± .20] PC board
- PBT insulator
- Molded-in key available
- 5 amp current rating
- 30 milli ohm maximum at rated current
- UL Flammability Rating: 94V-0

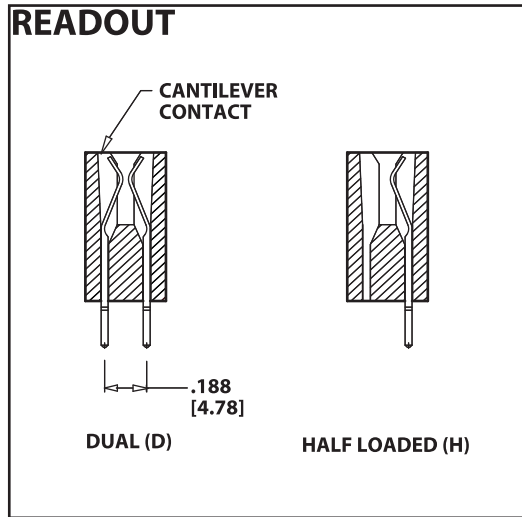
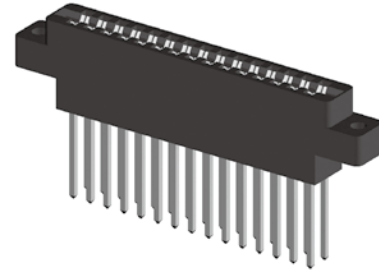

## TERMINATION TYPE

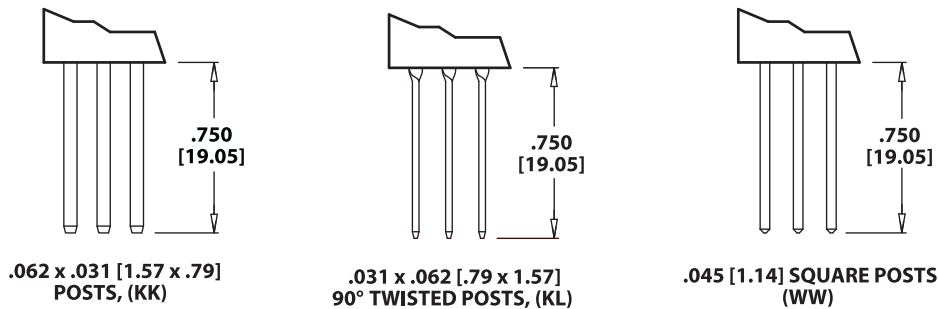

## MOUNTING STYLE

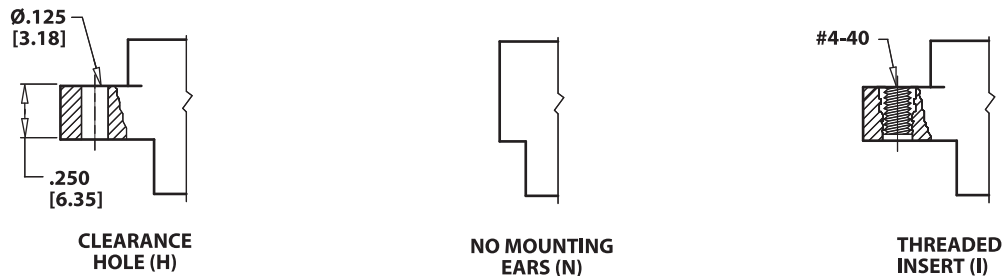

Sullins Female Card Edge



**.156" [3.96mm] Contact Centers, .720" [18.29 mm] Insulator Height  
.045" [1.14 mm] square / .031" [.79 mm] x .062" [1.57 mm] Wire Wrap**

**PART NUMBER OPTIONS**

**E B M 43 D KK H - Sxxx**

**MATERIALS (Insulator/Contact)**  
E = PBT/Phosphor Bronze (Standard)  
(Consult Factory For Other Materials)

**CONTACT FINISH - RoHS Compliant**  
All platings are Lead Free and have .000050" Nickel underplate

<b>Contact Surface</b>	<b>Termination</b>
B = .000010" Gold	.000100" Pure Tin, Matte
C = .000030" Gold	.000100" Pure Tin, Matte
G = .000010" Gold	.000005" Gold
Y = .000030" Gold	.000005" Gold
<b>Contact Surface</b>	<b>Overall Plating</b>
S = .000010" Gold	.000010" Gold
M = .000030" Gold	.000010" Gold
E = .000100" Pure Tin, Matte	.000100" Pure Tin, Matte

**MODIFICATION CODE (Consult Factory)**  
OMIT FOR STANDARD

**MOUNTING STYLE (Opposite page)**  
H = Clearance Hole  
N = No Mounting  
I = Threaded Inserts

**TERMINATION TYPE (Opposite Page)**  
KK = .031" [.79mm] x .062" [1.57mm] Post  
KL = .031" [.79mm] x .062" [1.57mm] Post, Twisted 90°  
WW = .045" [1.14mm] Square Post

**READOUT (Opposite Page)**  
D = Dual Row  
H = Half Loaded

**NUMBER OF CONTACT POSITIONS**  
See Chart Below

Sullins Female Card Edge

**DIMENSIONS** Dimensions in [ ] are in millimeters, all others are in inches.

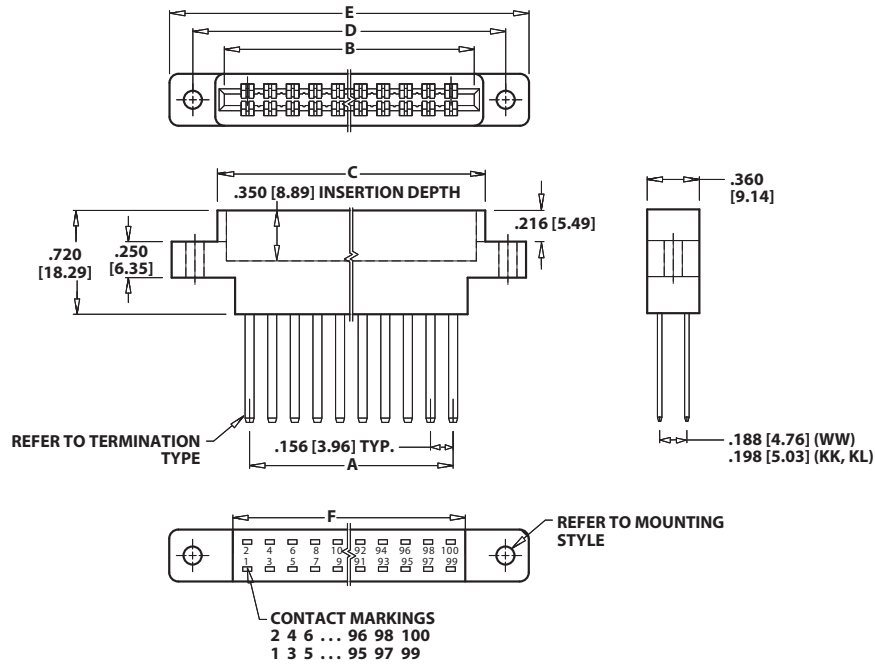

POSITIONS/ CONTACTS	INCHES						[MILLIMETERS]					
	A±.008	B±.008	C±.015	D±.010	E±.020	F±.015	A±0.20	B±0.20	C±0.38	D±0.25	E±0.51	F±0.38
06/12*	0.780	1.100	1.224	1.534	1.784	0.980	19.81	27.94	31.09	38.96	45.31	24.89
10/20	1.404	1.724	1.848	2.158	2.408	1.604	35.66	43.79	46.94	54.81	61.16	40.74
12/24	1.716	2.036	2.160	2.470	2.720	1.916	43.59	51.71	54.86	62.74	69.09	48.67
15/30	2.184	2.504	2.628	2.938	3.188	2.384	55.47	63.60	66.75	74.63	80.98	60.55
18/36	2.652	2.972	3.096	3.406	3.656	2.852	67.36	75.49	78.64	86.51	92.86	72.44
22/44	3.276	3.596	3.720	4.030	4.280	3.476	83.21	91.34	94.49	102.36	108.71	88.29
25/50*	3.744	4.064	4.188	4.498	4.748	3.944	95.10	103.23	106.38	114.25	120.60	100.18
28/56	4.212	4.532	4.656	4.966	5.216	4.412	106.98	115.11	118.26	126.14	132.49	112.06
30/60	4.524	4.844	4.968	5.278	5.528	4.724	114.91	123.04	126.19	134.06	140.41	119.99
31/62*	4.680	5.000	5.124	5.434	5.684	4.880	118.87	127.00	130.15	138.02	144.37	123.95
36/72	5.460	5.780	5.904	6.214	6.464	5.660	138.68	146.81	149.96	157.84	164.19	143.76
43/86*	6.552	6.872	6.996	7.306	7.556	6.752	166.42	174.55	177.70	185.57	191.92	171.50
50/100*	7.644	7.964	8.088	8.398	8.648	7.844	194.16	202.29	205.44	213.31	219.66	199.24

\* Consult Factory for availability.



**.100" [2.54 mm] Contact Centers, .550" [13.97 mm] or .610" [15.49 mm] Profile  
Press Fit**

**SPECIFICATIONS**

- UL Flammability Rating: 94V-0
- Designed to meet specifications of Bellcore specification TR-TSY-00078.
- Flat rock installation eliminates the need for any special installation tool.
- Integrally molded scoops available to assist daughter card entry.
- Various insulator options per customer requirements, including:
  - Open ended on one side
  - Open ended on both sides to accommodate end to end mounting
  - Molded in keys per customer requirements.

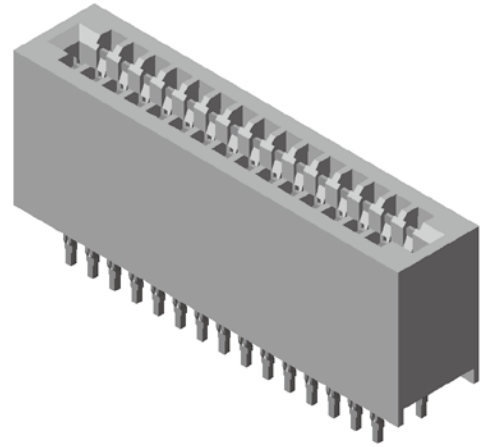

**FEATURES**

**COMPLIANT SECTION INSERTION FORCE**  
40 lbs maximum per contact

**COMPLIANT SECTION WITHDRAWAL FORCE**  
10 lbs minimum per contact

**HOLE SIZE REQUIREMENTS**  
Drilled Hole Diameter: .0453" ± .0010" [1.15 ± .03]  
Plating: .001"[.03] to .003"[.08] Copper and .0003" [.01] Minimum Tin

**FINISHED HOLE DIAMETER**  
.040" ± .003" [1.02 ± .08]

**SUITABLE FOR .062" [1.57] DAUGHTER CARD**

**RECOMMENDED MOTHERBOARD THICKNESS**  
.093" to .125" [2.36 to 3.18]

**UL-CUL RECOGNIZED**

**DIMENSIONS** Dimensions in [ ] are in millimeters, all others are in inches.

OPTIONAL SCOOPS .050 [1.27]

ACCEPTS .054 [1.37] TO .071 [1.80] P.C. BOARD

REFER TO TERMINATION TYPE (Opposite Page)

ROW SPACING SEE TERMINATION TYPE (Opposite Page)

-.100 [2.54]

-.100 [2.54] TYP.

-.078 [1.98] TYP.

-.370 [9.40]

-.100 [2.54]

-.025 [.64] SQ.

-.150 [3.81]

-.415 [10.54]

-.51136 (WITH SCOOPS) SHOWN ABOVE

WITHOUT STANDOFFS WITH STANDOFFS

STANDOFF VIEWS WITH NO SCOOPS SHOWN



**.100" [2.54 mm] Contact Centers, .550" [13.97 mm] or .610" [15.49 mm] Profile**

**PART NUMBER OPTIONS**

**E C C 43 D JB N - Sxxx**

**MATERIALS (Insulator/Contact)**  
E = PBT/Phosphor Bronze

**CONTACT FINISH - RoHS Compliant**  
All platings are Lead Free and have .000050" Nickel underplate  
**Contact Surface Termination**  
C = .000030" Gold .000100" Pure Tin, Matte

**CONTACT CENTERS**  
C = .100" [2.54mm]

**NUMBER OF CONTACT POSITIONS**  
See Chart Below

**READOUT**  
D = Dual

**MODIFICATIONS (Consult Factory)**  
OMIT FOR STANDARD  
Special Number assigned for specials such as:  
- Scoops (-S1136)  
- Other Card Slot Depths  
- Slim Line Body (.315" [8.00mm])

**MOUNTING STYLE**  
N = No Mounting  
B = Open Card Slot

**TERMINATION TYPE**

	Standoffs	Row Spacing	Tail Length
JB	No*	.200" [5.08mm]	.190" [4.83mm]
JC	No*	.200" [5.08mm]	.625" [15.88mm]
JW	Yes	.200" [5.08mm]	.190" [4.83mm]
JX	Yes	.200" [5.08mm]	.565" [14.35mm]
JF	No*	.100" [2.54mm]	.190" [4.83mm]
JG	No*	.100" [2.54mm]	.625" [15.88mm]
JY	Yes	.100" [2.54mm]	.190" [4.83mm]
JZ	Yes	.100" [2.54mm]	.565" [14.35mm]

\* Consult Factory For Availability

Sullins Press Fit

POSITIONS/ CONTACTS	A±.008[0.20]		B±.008[0.20]		C±.015[0.38]	
	INCH	[MM]	INCH	[MM]	INCH	[MM]
05/10	0.400	10.16	0.600	15.24	0.756	19.20
06/12	0.500	12.70	0.700	17.78	0.856	21.74
07/14	0.600	15.24	0.800	20.32	0.956	24.28
08/16*	0.700	17.78	0.900	22.86	1.056	26.82
09/18*	0.800	20.32	1.000	25.40	1.156	29.36
10/20	0.900	22.86	1.100	27.94	1.256	31.90
11/22*	1.000	25.40	1.200	30.48	1.356	34.44
12/24	1.100	27.94	1.300	33.02	1.456	36.98
13/26	1.200	30.48	1.400	35.56	1.556	39.52
14/28*	1.300	33.02	1.500	38.10	1.656	42.06
15/30	1.400	35.56	1.600	40.64	1.756	44.60
16/32	1.500	38.10	1.700	43.18	1.856	47.14
17/34	1.600	40.64	1.800	45.72	1.956	49.68
18/36	1.700	43.18	1.900	48.26	2.056	52.22
19/38*	1.800	45.72	2.000	50.80	2.156	54.76
20/40	1.900	48.26	2.100	53.34	2.256	57.30
21/42*	2.000	50.80	2.200	55.88	2.356	59.84
22/44	2.100	53.34	2.300	58.42	2.456	62.38
23/46	2.200	55.88	2.400	60.96	2.556	64.92
24/48	2.300	58.42	2.500	63.50	2.656	67.46
25/50	2.400	60.96	2.600	66.04	2.756	70.00
26/52*	2.500	63.50	2.700	68.58	2.856	72.54
27/54*	2.600	66.04	2.800	71.12	2.956	75.08
28/56	2.700	68.58	2.900	73.66	3.056	77.62
29/58*	2.800	71.12	3.000	76.20	3.156	80.16
30/60	2.900	73.66	3.100	78.74	3.256	82.70
31/62	3.000	76.20	3.200	81.28	3.356	85.24
32/64*	3.100	78.74	3.300	83.82	3.456	87.78

POSITIONS/ CONTACTS	A±.008[0.20]		B±.008[0.20]		C±.015[0.38]	
	INCH	[MM]	INCH	[MM]	INCH	[MM]
33/66*	3.200	81.28	3.400	86.36	3.556	90.32
34/68	3.300	83.82	3.500	88.90	3.656	92.86
35/70	3.400	86.36	3.600	91.44	3.756	95.40
36/72	3.500	88.90	3.700	93.98	3.856	97.94
37/74*	3.600	91.44	3.800	96.52	3.956	100.48
38/76*	3.700	93.98	3.900	99.06	4.056	103.02
39/78*	3.800	96.52	4.000	101.60	4.156	105.56
40/80	3.900	99.06	4.100	104.14	4.256	108.10
41/82*	4.000	101.60	4.200	106.68	4.356	110.64
42/84*	4.100	104.14	4.300	109.22	4.456	113.18
43/86	4.200	106.68	4.400	111.76	4.556	115.72
44/88*	4.300	109.22	4.500	114.30	4.656	118.26
45/90*	4.400	111.76	4.600	116.84	4.756	120.80
46/92*	4.500	114.30	4.700	119.38	4.856	123.34
47/94*	4.600	116.84	4.800	121.92	4.956	125.88
48/96*	4.700	119.38	4.900	124.46	5.056	128.42
49/98*	4.800	121.92	5.000	127.00	5.156	130.96
50/100	4.900	124.46	5.100	129.54	5.256	133.50
51/102*	5.000	127.00	5.200	132.08	5.356	136.04
52/104*	5.100	129.54	5.300	134.62	5.456	138.58
53/106*	5.200	132.08	5.400	137.16	5.556	141.12
54/108*	5.300	134.62	5.500	139.70	5.656	143.66
55/110*	5.400	137.16	5.600	142.24	5.756	146.20
56/112*	5.500	139.70	5.700	144.78	5.856	148.74
57/114*	5.600	142.24	5.800	147.32	5.956	151.28
58/116*	5.700	144.78	5.900	149.86	6.056	153.82
59/118*	5.800	147.32	6.000	152.40	6.156	156.36
60/120	5.900	149.86	6.100	154.94	6.256	158.90

\* Consult Factory For Availability.



**.156" [3.96 mm] Contact Centers, .550" [13.97 mm] or .610" [15.49 mm] Profile  
Press Fit**

**SPECIFICATIONS**

- Designed to meet specifications of Bellcore specification TR-TSY-00078.
- Flat rock installation eliminates the need for any special installation tool.
- Integrally molded scoops available to assist daughter card entry.
- Various insulator options per customer requirements, including:
  - Open ended on one side
  - Open ended on both sides to accommodate end to end mounting
  - Molded in keys per customer requirements.

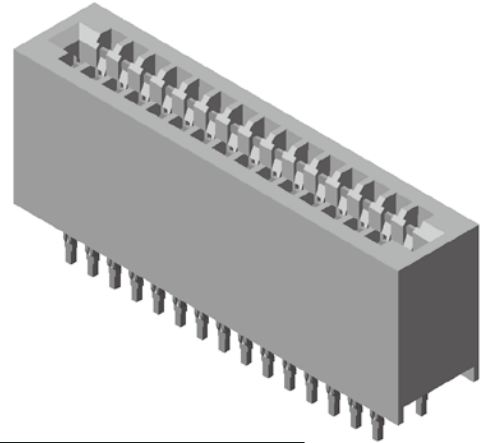

**FEATURES**

**COMPLIANT SECTION INSERTION FORCE**  
40 lbs maximum per contact

**COMPLIANT SECTION WITHDRAWAL FORCE**  
10 lbs minimum per contact

**HOLE SIZE REQUIREMENTS**  
Drilled Hole Diameter:  $.0453" \pm .0010"$  [1.15 ± .03]  
Plating:  $.001"$  [.03] to  $.003"$  [.08] Copper and  $.0003"$  [.01] Minimum Tin

**FINISHED HOLE DIAMETER**  
 $.040" \pm .003"$  [1.02 ± .08]

**SUITABLE FOR .062" [1.57] DAUGHTER CARD**

**RECOMMENDED MOTHERBOARD THICKNESS**  
 $.093"$  to  $.125"$  [2.36 to 3.18]

**UL-CUL RECOGNIZED**

**DIMENSIONS** Dimensions in [ ] are in millimeters, all others are in inches.

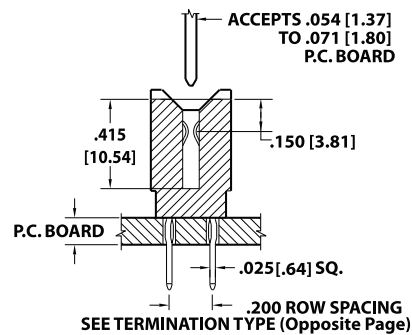
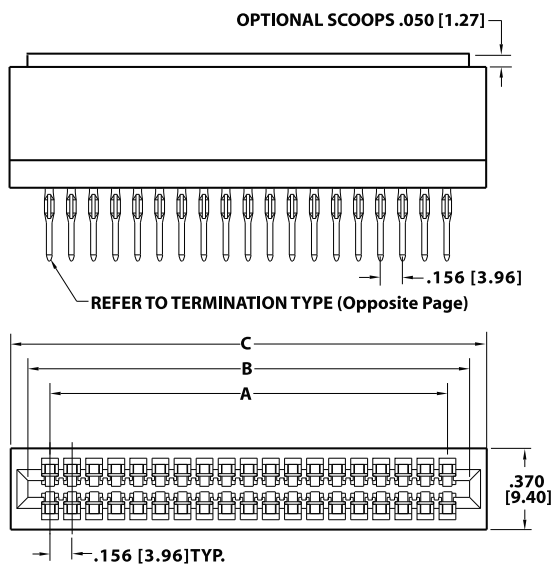

-S1136 (WITH SCOOPS) SHOWN ABOVE

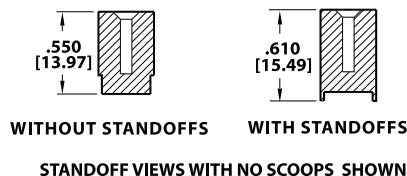



**.156" [3.96 mm] Contact Centers, .550" [13.97 mm] or .610" [15.49 mm] Profile**

**PART NUMBER OPTIONS**

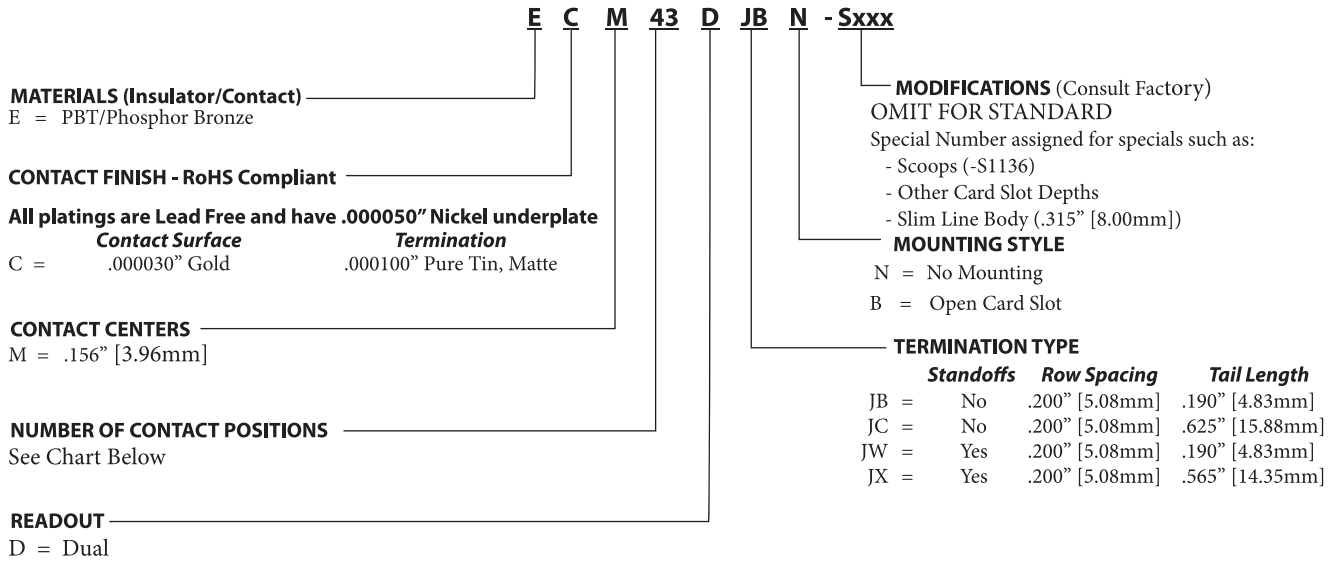

POSITIONS/ CONTACTS	A±.008[0.20]		B±.008[0.20]		C±.015[0.38]	
	INCH	[MM]	INCH	[MM]	INCH	[MM]
05/10*	0.624	15.85	0.944	23.98	1.080	27.43
06/12*	0.780	19.81	1.100	27.94	1.236	31.39
07/14*	0.936	23.77	1.256	31.90	1.392	35.36
08/16*	1.092	27.74	1.412	35.86	1.548	39.32
09/18*	1.248	31.70	1.568	39.83	1.704	43.28
10/20	1.404	35.66	1.724	43.79	1.860	47.24
11/22*	1.560	39.62	1.880	47.75	2.016	51.21
12/24*	1.716	43.59	2.036	51.71	2.172	55.17
13/26*	1.872	47.55	2.192	55.68	2.328	59.13
14/28*	2.028	51.51	2.348	59.64	2.484	63.09
15/30*	2.184	55.47	2.504	63.60	2.640	67.06
16/32*	2.340	59.44	2.660	67.56	2.796	71.02
17/34*	2.496	63.40	2.816	71.53	2.952	74.98
18/36*	2.652	67.36	2.972	75.49	3.108	78.94
19/38*	2.808	71.32	3.128	79.45	3.264	82.91
20/40*	2.964	75.29	3.284	83.41	3.420	86.87
21/42*	3.120	79.25	3.440	87.38	3.576	90.83
22/44	3.276	83.21	3.596	91.34	3.732	94.79

POSITIONS/ CONTACTS	A±.008[0.20]		B±.008[0.20]		C±.015[0.38]	
	INCH	[MM]	INCH	[MM]	INCH	[MM]
23/46*	3.432	87.17	3.752	95.30	3.888	98.76
24/48*	3.588	91.14	3.908	99.26	4.044	102.72
25/50*	3.744	95.10	4.064	103.23	4.200	106.68
26/52*	3.900	99.06	4.220	107.19	4.356	110.64
27/54*	4.056	103.02	4.376	111.15	4.512	114.60
28/56*	4.212	106.98	4.532	115.11	4.668	118.57
29/58*	4.368	110.95	4.688	119.08	4.824	122.53
30/60*	4.524	114.91	4.844	123.04	4.980	126.49
31/62*	4.680	118.87	5.000	127.00	5.136	130.45
32/64*	4.836	122.83	5.156	130.96	5.292	134.42
33/66*	4.992	126.80	5.312	134.92	5.448	138.38
34/68*	5.148	130.76	5.468	138.89	5.604	142.34
35/70*	5.304	134.72	5.624	142.85	5.760	146.30
36/72*	5.460	138.68	5.780	146.81	5.916	150.27
37/74*	5.616	142.65	5.936	150.77	6.072	154.23
38/76*	5.772	146.61	6.092	154.74	6.228	158.19
39/78*	5.928	150.57	6.248	158.70	6.384	162.15

\* Consult Factory For Availability.

Sullins Press Fit



**1.00 mm [.039"] Contact Centers, Male Headers/Straight/Right Angle/SMT-SMH Series**  
*Mates with SFM series*

**SPECIFICATIONS**

- 1 amp current rating
- UL Flammability Rating: 94V-0
- Insulator Material: Black LCP
- Contact Material: Phosphor Bronze
- Insulator Resistance: 1000 Mega OHMS Min.
- Contact Resistance: 20 Milli OHMS Max.
- Dielectric Withstanding: AC 300V
- Operating Temperature: -40°C to +125°C
- Processing Temperature: 260°C for 10 seconds Max.
- Stacker Options available - Consult factory

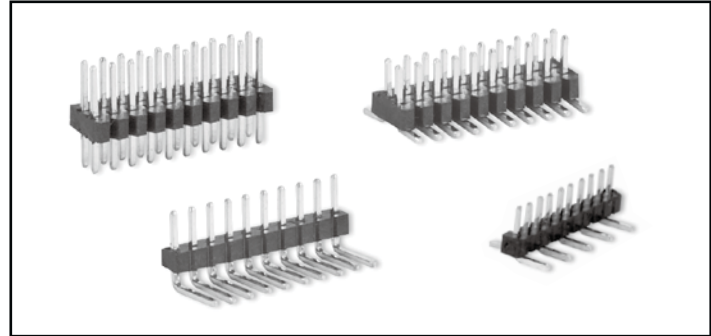

**TERMINATION TYPE**

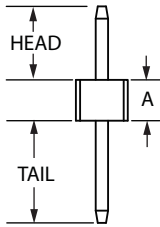

**Straight, (ST)**

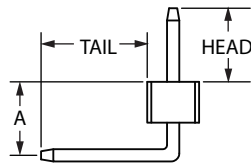

**Right Angle, (RA)**

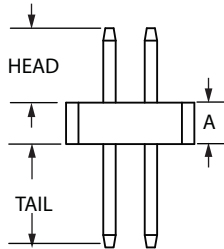

**Straight, (ST)**

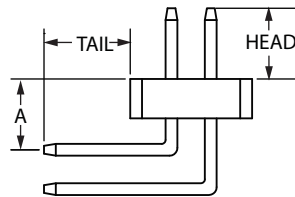

**Right Angle, (RA)**

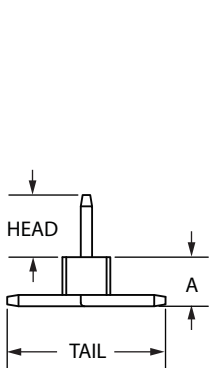

**SMT, (SC) or (SD)**

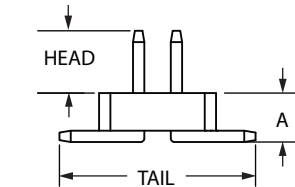

**SMT Without Guide Posts, (SM)**

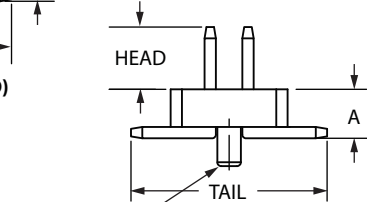

**SMT With Guide Posts, (SP)**

**SINGLE ROW**

EXAMPLE P/N	HEAD	TAIL	A
<b>STRAIGHT TERMINATION</b>			
SMH100-LPPE-S10-ST-BK	1.80 [.071"]	2.50 [.098"]	1.00 [.039"]
<b>RIGHT ANGLE TERMINATION</b>			
SMH100-LPPE-S10-RA-BK	1.80 [.071"]	2.60 [.102"]	1.00 [.039"]

**DUAL ROW**

EXAMPLE P/N	HEAD	TAIL	A
<b>STRAIGHT TERMINATIONS</b>			
SMH100-LPPE-D10-ST-BK	1.80 [.071"]	2.50 [.098"]	1.00 [.039"]
SMH150-LPPE-D10-ST-BK	1.80 [.071"]	2.50 [.098"]	1.50 [.059"]
<b>RIGHT ANGLE TERMINATION</b>			
SMH100-LPPE-D10-RA-BK	1.80 [.071"]	2.60 [.102"]	1.00 [.039"]

**SURFACE MOUNT TERMINATIONS**

EXAMPLE P/N	HEAD	TAIL	A
<b>SINGLE ROW</b>			
SMH100-LPPE-S10-SC-BK	1.65 [.065"]	4.20 [.165"]	1.30 [.051"]
SMH100-LPPE-S10-SD-BK	1.65 [.065"]	4.20 [.165"]	1.30 [.051"]
<b>DUAL ROW</b>			
SMH101-LPPE-D10-SM-BK	1.65 [.065"]	5.20 [.205"]	1.30 [.051"]
SMH101-LPPE-D10-SP-BK	1.65 [.065"]	5.20 [.205"]	1.30 [.051"]
SMH102-LPPE-D10-SM-BK	1.90 [.075"]	5.20 [.205"]	1.30 [.051"]
SMH102-LPPE-D10-SP-BK	1.90 [.075"]	5.20 [.205"]	1.30 [.051"]
SMH151-LPPE-D10-SM-BK	1.65 [.065"]	5.20 [.205"]	1.80 [.071"]
SMH151-LPPE-D10-SP-BK	1.65 [.065"]	5.20 [.205"]	1.80 [.071"]
SMH152-LPPE-D10-SM-BK	1.90 [.075"]	5.20 [.205"]	1.80 [.071"]
SMH152-LPPE-D10-SP-BK	1.90 [.075"]	5.20 [.205"]	1.80 [.071"]

Sullins Headers



**1.00 mm [.039"] Contact Centers, Male Headers/Straight/Right Angle/SMT-SMH Series**  
*Mates with SFM series*

**PART NUMBER OPTIONS**

**SMH100 - L P P E - S 10 - ST - BK**

**SERIES (See Opposite Page)**

- SMH100 = 1.00 [.039"] Profile, 1.80 [.071"] Head Height
- SMH101 = 1.00 [.039"] Profile, 1.65 [.065"] Head Height
- SMH102 = 1.00 [.039"] Profile, 1.90 [.075"] Head Height
- SMH150 = 1.50 [.059"] Profile, 1.80 [.071"] Head Height
- SMH151 = 1.50 [.059"] Profile, 1.65 [.065"] Head Height
- SMH152 = 1.50 [.059"] Profile, 1.90 [.075"] Head Height

**HOUSING MATERIAL**

L = LCP

**CONTACT MATERIAL**

P = Phosphor Bronze

**CONTACT FINISH - RoHS Compliant**

P = Gold Flash Overall

S = 10u" Gold Overall

**CONTACT CENTERS**

E = 1.00 mm [.039"]

**COLOR**

BK = Black

**TERMINATION TYPE (See Opposite Page)**

- ST = Straight (1 & 2 Row)
- RA = Right Angle (1 & 2 Row)
- SC = Surface Mount, Standard (1 Row)
- SD = Surface Mount, Opposite Bend, Applicable on Even pin Counts (1 Row)
- SM = Surface Mount without Guide Posts (2 Row)
- SP = Surface Mount with Guide Posts (2 Row)

**NUMBER OF CONTACT POSITIONS (Pins per Row)**

02 thru 50

**NUMBER OF ROWS**

- S = Single Row
- D = Dual Row

**DIMENSIONS**

**STRAIGHT (SHOWN) & RIGHT ANGLE**

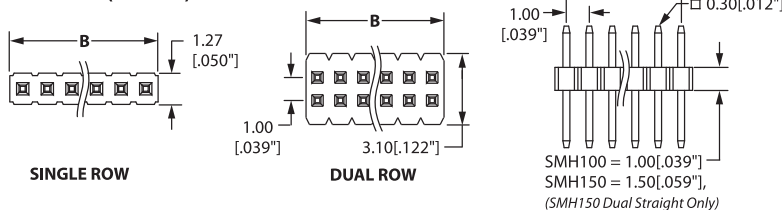

**SURFACE MOUNT, DUAL ROW**

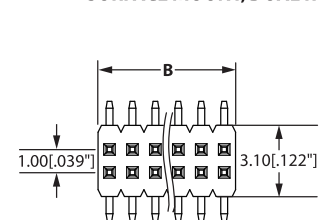

**SURFACE MOUNT, SINGLE ROW**

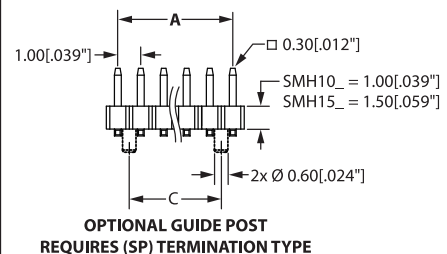
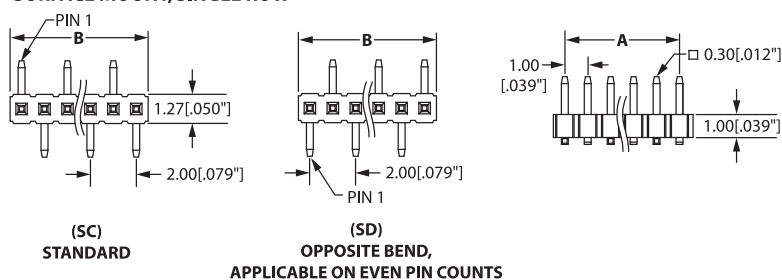

Positions	Number of Contacts Single/Dual	A		B		C	
		mm	[Inches]	mm	[Inches]	mm	[Inches]
02*	02/04	1.00	0.039	2.00	0.079	N/A	N/A
03	03/06	2.00	0.079	3.00	0.118	1.00	0.039
04	04/08	3.00	0.118	4.00	0.157	2.00	0.079
05	05/10	4.00	0.157	5.00	0.197	3.00	0.118
06	06/12	5.00	0.197	6.00	0.236	4.00	0.157
07	07/14	6.00	0.236	7.00	0.276	5.00	0.197
08	08/16	7.00	0.276	8.00	0.315	6.00	0.236
09	09/18	8.00	0.315	9.00	0.354	7.00	0.276
10	10/20	9.00	0.354	10.00	0.394	8.00	0.315
11	11/22	10.00	0.394	11.00	0.433	9.00	0.354
12	12/24	11.00	0.433	12.00	0.472	10.00	0.394
13	13/26	12.00	0.472	13.00	0.512	11.00	0.433
14	14/28	13.00	0.512	14.00	0.551	12.00	0.472
15	15/30	14.00	0.551	15.00	0.591	13.00	0.512
16	16/32	15.00	0.591	16.00	0.630	14.00	0.551
17	17/34	16.00	0.630	17.00	0.669	15.00	0.591
18	18/36	17.00	0.669	18.00	0.709	16.00	0.630
19	19/38	18.00	0.709	19.00	0.748	17.00	0.669
20	20/40	19.00	0.748	20.00	0.787	18.00	0.709
21	21/42	20.00	0.787	21.00	0.827	19.00	0.748
22	22/44	21.00	0.827	22.00	0.866	20.00	0.787
23	23/46	22.00	0.866	23.00	0.906	21.00	0.827
24	24/48	23.00	0.906	24.00	0.945	22.00	0.866
25	25/50	24.00	0.945	25.00	0.984	23.00	0.906

Positions	Number of Contacts Single/Dual	A		B		C	
		mm	[Inches]	mm	[Inches]	mm	[Inches]
26	26/52	25.00	0.984	26.00	1.024	24.00	0.945
27	27/54	26.00	1.024	27.00	1.063	25.00	0.984
28	28/56	27.00	1.063	28.00	1.102	26.00	1.024
29	29/58	28.00	1.102	29.00	1.142	27.00	1.063
30	30/60	29.00	1.142	30.00	1.181	28.00	1.102
31	31/62	30.00	1.181	31.00	1.220	29.00	1.142
32	32/64	31.00	1.220	32.00	1.260	30.00	1.181
33	33/66	32.00	1.260	33.00	1.299	31.00	1.220
34	34/68	33.00	1.299	34.00	1.339	32.00	1.260
35	35/70	34.00	1.339	35.00	1.378	33.00	1.299
36	36/72	35.00	1.378	36.00	1.417	34.00	1.339
37	37/74	36.00	1.417	37.00	1.457	35.00	1.378
38	38/76	37.00	1.457	38.00	1.496	36.00	1.417
39	39/78	38.00	1.496	39.00	1.535	37.00	1.457
40	40/80	39.00	1.535	40.00	1.575	38.00	1.496
41	41/82	40.00	1.575	41.00	1.614	39.00	1.535
42	42/84	41.00	1.614	42.00	1.654	40.00	1.575
43	43/86	42.00	1.654	43.00	1.693	41.00	1.614
44	44/88	43.00	1.693	44.00	1.732	42.00	1.654
45	45/90	44.00	1.732	45.00	1.772	43.00	1.693
46	46/92	45.00	1.772	46.00	1.811	44.00	1.732
47	47/94	46.00	1.811	47.00	1.850	45.00	1.772
48	48/96	47.00	1.850	48.00	1.890	46.00	1.811
49	49/98	48.00	1.890	49.00	1.929	47.00	1.850
50	50/100	49.00	1.929	50.00	1.969	48.00	1.890

\* Position 2 not available with Guide posts.



**1.00 mm [.039"] Contact Centers, Female Headers, Straight/SMT- SFM Series**  
*Mates with SMH series*

**SPECIFICATIONS**

- 1 amp current rating
- UL Flammability Rating: 94V-0
- Insulator Material: Black LCP
- Contact Material: Phosphor Bronze
- Contact Resistance: 20 Milli OHMS Max.
- Operating Temperature: -40°C to +125°C
- Processing Temperature: 260°C for 10 seconds Max.

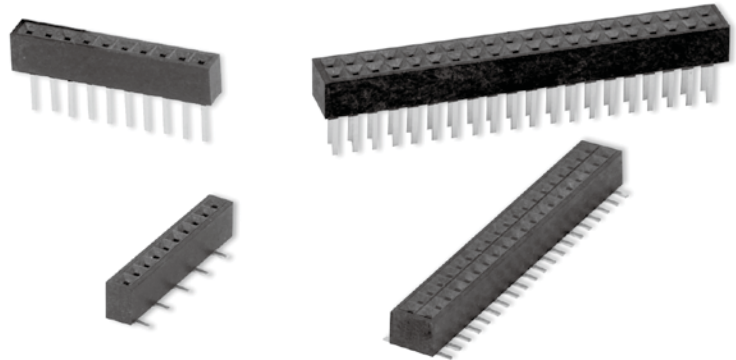

**TERMINATION TYPE**

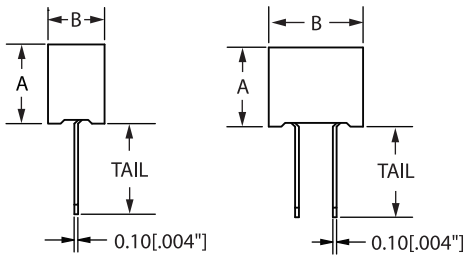

**Single Row, Straight, (ST)**

**Dual Row, Straight, (ST)**

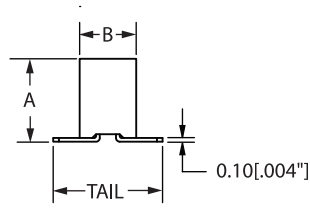

**Single Row, SMT, Pin 1 Left (SC) or SMT, Pin 1 Right (SD)**

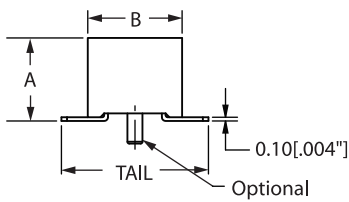

**SFM210-, Dual Row, SMT Without Guide Posts (SM) or SMT With Guide Posts (SP)**

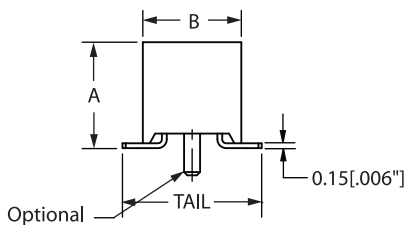

**SFM315-, Dual Row, SMT Without Guide Posts (SM) or SMT With Guide Posts (SP)**

**STRAIGHT**

EXAMPLE P/N	A	B	TAIL
<b>SINGLE ROW</b>			
SFM210-LPPE-S10-SI-BK	2.10 [.083"]	1.50 [.059"]	2.40 [.094"]
<b>DUAL ROW</b>			
SFM210-LPPE-D10-SI-BK	2.10 [.083"]	2.50 [.098"]	2.40 [.094"]

**SURFACE MOUNT**

EXAMPLE P/N	A	B	TAIL
<b>SINGLE ROW</b>			
SFM210-LPPE-S10-SC-BK	2.20 [.087"]	1.50 [.059"]	2.90 [.114"]
SFM210-LPPE-S10-SD-BK	2.20 [.087"]	1.50 [.059"]	2.90 [.114"]

**SURFACE MOUNT**

EXAMPLE P/N	A	B	TAIL
<b>DUAL ROW</b>			
SFM210-LPPE-D10-SM-BK	2.20 [.087"]	2.50 [.098"]	3.90 [.154"]
SFM210-LPPE-D10-SP-BK	2.20 [.087"]	2.50 [.098"]	3.90 [.154"]

**SURFACE MOUNT**

EXAMPLE P/N	A	B	TAIL
<b>DUAL ROW</b>			
SFM315-LPPE-D10-SM-BK	3.30 [.130"]	3.07 [.121"]	4.34 [.171"]
SFM315-LPPE-D10-SP-BK	3.30 [.130"]	3.07 [.121"]	4.34 [.171"]

Sullins Headers



**1.00 mm [.039"] Contact Centers, Female Headers, Straight/SMT- SFM Series**  
*Mates with SMH series*

**PART NUMBER OPTIONS**

**SFM210 - L P P E - S 10 - ST - BK**

**SERIES (See Opposite Page)**  
SFM210 = 2.10 mm [.083"] Profile  
SFM315 = 3.15 mm [.124"] Profile

**HOUSING MATERIAL**  
L = LCP

**CONTACT MATERIAL**  
P = Phosphor Bronze

**CONTACT FINISH - RoHS Compliant**  
P = Gold Flash Overall  
S = 10u" Gold Overall, (Not Available on SFM315 series)  
G = 10u" Gold on Contact Surface, Gold Flash on Termination, (Not Available on SFM210 series)

**CONTACT CENTERS**  
E = 1.00 mm [.039"]

**COLOR**  
BK = Black

**TERMINATION TYPE (See Opposite Page)**  
ST = Straight (1 & 2 Row)  
SC = Surface Mount, Standard (1 Row)  
SD = Surface Mount, Opposite Bend, Applicable on Even pin counts (1 Row)  
SM = Surface Mount without Guide Posts (2 Row)  
SP = Surface Mount with Guide Posts (2 Row)

**NUMBER OF CONTACT POSITIONS (Pins per Row)**  
02 thru 50

**NUMBER OF ROWS**  
S = Single Row  
D = Dual Row

**DIMENSIONS**

**STRAIGHT**

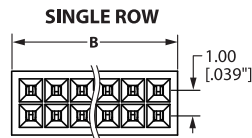
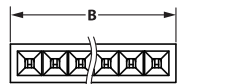
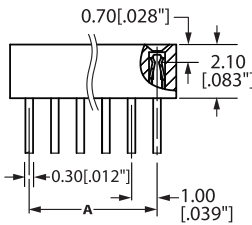

**DUAL ROW**

**Surface Mount Top/Bottom Entry, Single Row**

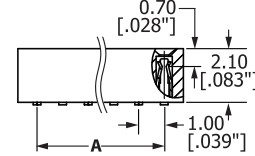
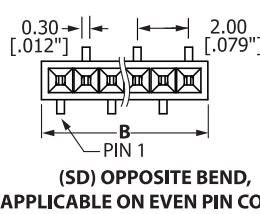
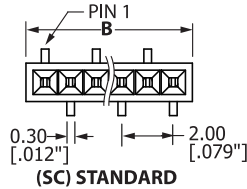

**Surface Mount Top/Bottom Entry, Dual Row**

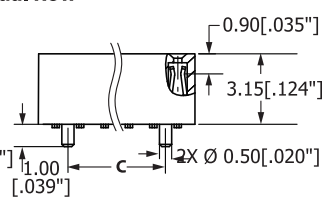
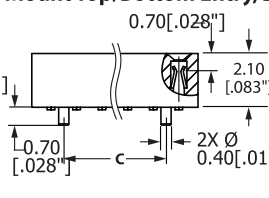
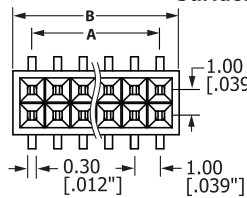

**SFM210- SFM315- OPTIONAL GUIDE POSTS REQUIRE (SP) TERMINATION TYPE**

No. of Contacts Single/ Dual	DIMENSION A		DIMENSION B (SFM210)		DIMENSION B (SFM315)		DIMENSION C		No. of Contacts Single/ Dual	DIMENSION A		DIMENSION B (SFM210)		DIMENSION B (SFM315)		DIMENSION C	
	mm	[inch]	mm	[inch]	mm	[inch]	mm	[inch]		mm	[inch]	mm	[inch]	mm	[inch]	mm	[inch]
02/04*	1.00	0.039	2.50	0.098	2.40	0.094	N/A	N/A	26/52	25.00	0.984	26.50	1.043	26.40	1.039	24.00	0.945
03/06	2.00	0.079	3.50	0.138	3.40	0.134	1.00	0.039	27/54	26.00	1.024	27.50	1.083	27.40	1.079	25.00	0.984
04/08	3.00	0.118	4.50	0.177	4.40	0.173	2.00	0.079	28/56	27.00	1.063	28.50	1.122	28.40	1.118	26.00	1.024
05/10	4.00	0.157	5.50	0.217	5.40	0.213	3.00	0.118	29/58	28.00	1.102	29.50	1.161	29.40	1.157	27.00	1.063
06/12	5.00	0.197	6.50	0.256	6.40	0.252	4.00	0.157	30/60	29.00	1.142	30.50	1.201	30.40	1.197	28.00	1.102
07/14	6.00	0.236	7.50	0.295	7.40	0.291	5.00	0.197	31/62	30.00	1.181	31.50	1.240	31.40	1.236	29.00	1.142
08/16	7.00	0.276	8.50	0.335	8.40	0.331	6.00	0.236	32/64	31.00	1.220	32.50	1.280	32.40	1.276	30.00	1.181
09/18	8.00	0.315	9.50	0.374	9.40	0.370	7.00	0.276	33/66	32.00	1.260	33.50	1.319	33.40	1.315	31.00	1.220
10/20	9.00	0.354	10.50	0.413	10.40	0.409	8.00	0.315	34/68	33.00	1.299	34.50	1.358	34.40	1.354	32.00	1.260
11/22	10.00	0.394	11.50	0.453	11.40	0.449	9.00	0.354	35/70	34.00	1.339	35.50	1.398	35.40	1.394	33.00	1.299
12/24	11.00	0.433	12.50	0.492	12.40	0.488	10.00	0.394	36/72	35.00	1.378	36.50	1.437	36.40	1.433	34.00	1.339
13/26	12.00	0.472	13.50	0.531	13.40	0.528	11.00	0.433	37/74	36.00	1.417	37.50	1.476	37.40	1.472	35.00	1.378
14/28	13.00	0.512	14.50	0.571	14.40	0.567	12.00	0.472	38/76	37.00	1.457	38.50	1.516	38.40	1.512	36.00	1.417
15/30	14.00	0.551	15.50	0.610	15.40	0.606	13.00	0.512	39/78	38.00	1.496	39.50	1.555	39.40	1.551	37.00	1.457
16/32	15.00	0.591	16.50	0.650	16.40	0.646	14.00	0.551	40/80	39.00	1.535	40.50	1.594	40.40	1.591	38.00	1.496
17/34	16.00	0.630	17.50	0.689	17.40	0.685	15.00	0.591	41/82	40.00	1.575	41.50	1.634	41.40	1.630	39.00	1.535
18/36	17.00	0.669	18.50	0.728	18.40	0.724	16.00	0.630	42/84	41.00	1.614	42.50	1.673	42.40	1.669	40.00	1.575
19/38	18.00	0.709	19.50	0.768	19.40	0.764	17.00	0.669	43/86	42.00	1.654	43.50	1.713	43.40	1.709	41.00	1.614
20/40**	19.00	0.748	20.50	0.807	20.40	0.803	18.00	0.709	44/88	43.00	1.693	44.50	1.752	44.40	1.748	42.00	1.654
21/42	20.00	0.787	21.50	0.846	21.40	0.843	19.00	0.748	45/90	44.00	1.732	45.50	1.791	45.40	1.787	43.00	1.693
22/44	21.00	0.827	22.50	0.886	22.40	0.882	20.00	0.787	46/92	45.00	1.772	46.50	1.831	46.40	1.827	44.00	1.732
23/46	22.00	0.866	23.50	0.925	23.40	0.921	21.00	0.827	47/94	46.00	1.811	47.50	1.870	47.40	1.866	45.00	1.772
24/48	23.00	0.906	24.50	0.965	24.40	0.961	22.00	0.866	48/96	47.00	1.850	48.50	1.909	48.40	1.906	46.00	1.811
25/50	24.00	0.945	25.50	1.004	25.40	1.000	23.00	0.906	49/98	48.00	1.890	49.50	1.949	49.40	1.945	47.00	1.850
									50/100	49.00	1.929	50.50	1.988	50.40	1.984	48.00	1.890

\* Position 2 not available with guide posts on SFM210 Series (Termination Type SP). \*\* Position 20 not available on SFM315 Series.



**1.00mm [.039"] Contact Centers, Shrouded (Box) Headers Straight/SMT  
Mates With SFM210 Series**

**SPECIFICATIONS**

- Operating Temperature: - 40°C to + 125°C
- Processing Temperature: 230°C for 60 seconds Max.  
(260°C, 10 seconds Max.)
- UL Flammability Rating: 94V-0
- Contact Resistance: 20m OHMs Max.
- Current Rating: 1 AMP per contact
- Dielectric Withstanding Voltage: 300 VAC.
- Insulation Resistance: 1000 Mega OHMS Min.

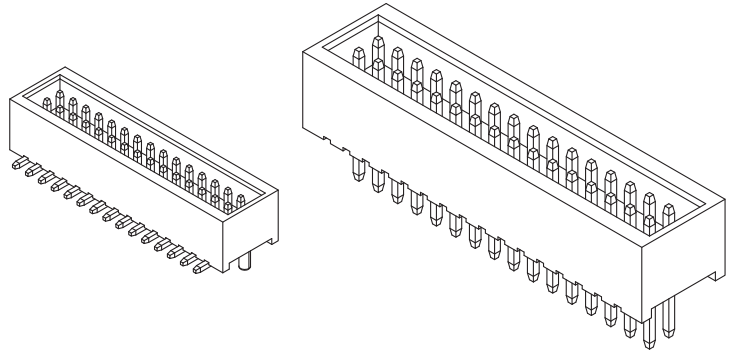

**DIMENSIONS** For complete drawings, go to [www.sullinscorp.com](http://www.sullinscorp.com) or e-mail [techsupport@sullinscorp.com](mailto:techsupport@sullinscorp.com)

**SURFACE MOUNT (SP or SM)**

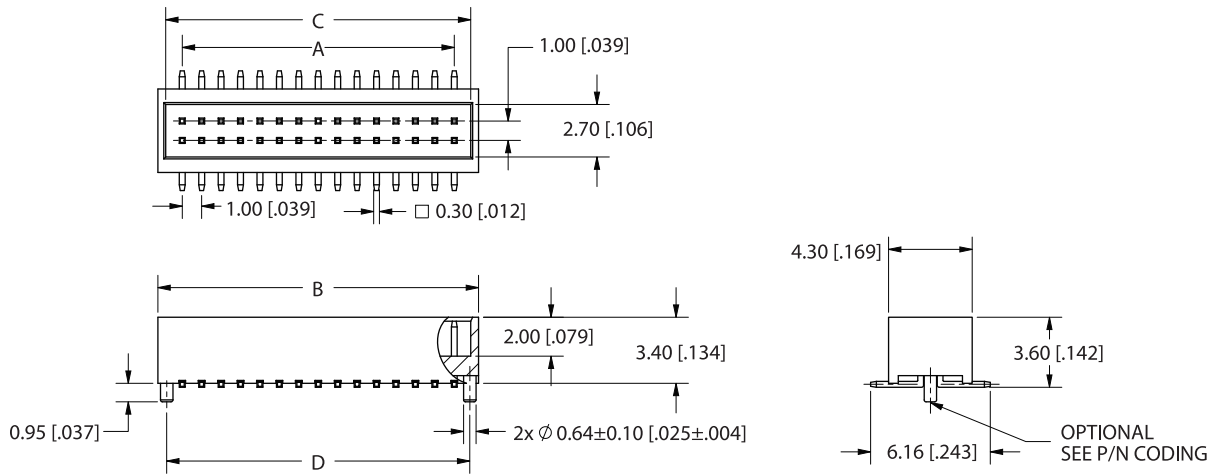

**STRAIGHT (ST)**

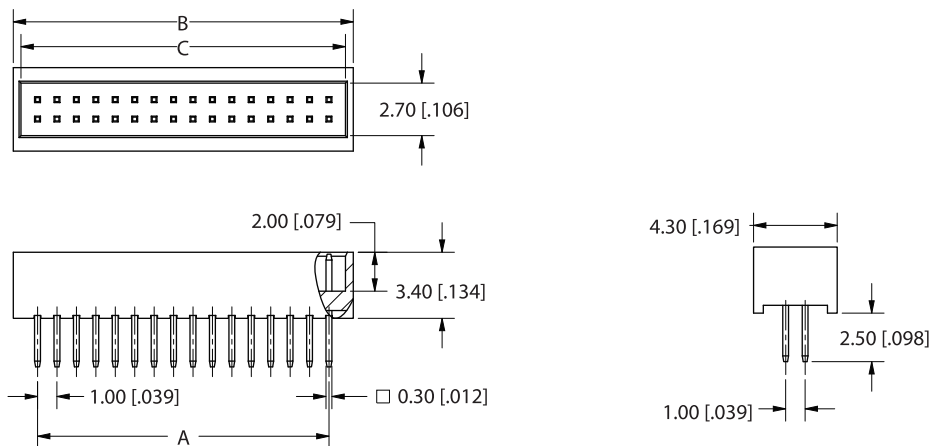

Sullins Headers



**1.00mm [.039"] Contact Centers, Shrouded (Box) Headers Straight/SMT  
Mates With SFM210 Series**

**PART NUMBER OPTIONS**

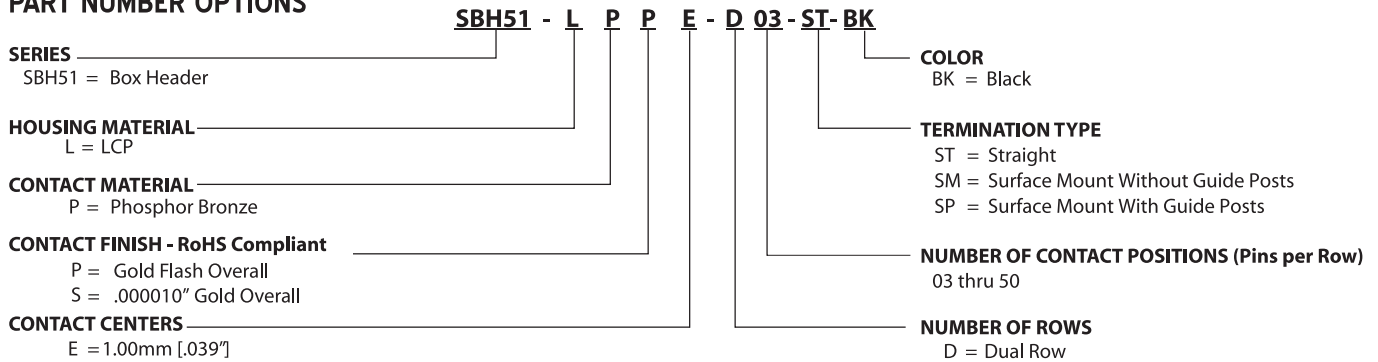

PART NUMBER	POSITIONS/ CONTACTS	A		B		C		D	
		mm	inch	mm	inch	mm	inch	mm	inch
SBH51-LP_E-D03-__-BK	03/06	2.00	0.079	4.50	0.177	3.70	0.146	3.60	0.142
SBH51-LP_E-D04-__-BK	04/08	3.00	0.118	5.50	0.217	4.70	0.185	4.60	0.181
SBH51-LP_E-D05-__-BK	05/10	4.00	0.157	6.50	0.256	5.70	0.224	5.60	0.220
SBH51-LP_E-D06-__-BK	06/12	5.00	0.197	7.50	0.295	6.70	0.264	6.60	0.260
SBH51-LP_E-D07-__-BK	07/14	6.00	0.236	8.50	0.335	7.70	0.303	7.60	0.299
SBH51-LP_E-D08-__-BK	08/16	7.00	0.276	9.50	0.374	8.70	0.343	8.60	0.339
SBH51-LP_E-D09-__-BK	09/18	8.00	0.315	10.50	0.413	9.70	0.382	9.60	0.378
SBH51-LP_E-D10-__-BK	10/20	9.00	0.354	11.50	0.453	10.70	0.421	10.60	0.417
SBH51-LP_E-D11-__-BK	11/22	10.00	0.394	12.50	0.492	11.70	0.461	11.60	0.457
SBH51-LP_E-D12-__-BK	12/24	11.00	0.433	13.50	0.531	12.70	0.500	12.60	0.496
SBH51-LP_E-D13-__-BK	13/26	12.00	0.472	14.50	0.571	13.70	0.539	13.60	0.535
SBH51-LP_E-D14-__-BK	14/28	13.00	0.512	15.50	0.610	14.70	0.579	14.60	0.575
SBH51-LP_E-D15-__-BK	15/30	14.00	0.551	16.50	0.650	15.70	0.618	15.60	0.614
SBH51-LP_E-D16-__-BK	16/32	15.00	0.591	17.50	0.689	16.70	0.657	16.60	0.654
SBH51-LP_E-D17-__-BK	17/34	16.00	0.630	18.50	0.728	17.70	0.697	17.60	0.693
SBH51-LP_E-D18-__-BK	18/36	17.00	0.669	19.50	0.768	18.70	0.736	18.60	0.732
SBH51-LP_E-D19-__-BK	19/38	18.00	0.709	20.50	0.807	19.70	0.776	19.60	0.772
SBH51-LP_E-D20-__-BK	20/40	19.00	0.748	21.50	0.846	20.70	0.815	20.60	0.811
SBH51-LP_E-D21-__-BK	21/42	20.00	0.787	22.50	0.886	21.70	0.854	21.60	0.850
SBH51-LP_E-D22-__-BK	22/44	21.00	0.827	23.50	0.925	22.70	0.894	22.60	0.890
SBH51-LP_E-D23-__-BK	23/46	22.00	0.866	24.50	0.965	23.70	0.933	23.60	0.929
SBH51-LP_E-D24-__-BK	24/48	23.00	0.906	25.50	1.004	24.70	0.972	24.60	0.969
SBH51-LP_E-D25-__-BK	25/50	24.00	0.945	26.50	1.043	25.70	1.012	25.60	1.008
SBH51-LP_E-D26-__-BK	26/52	25.00	0.984	27.50	1.083	26.70	1.051	26.60	1.047
SBH51-LP_E-D27-__-BK	27/54	26.00	1.024	28.50	1.122	27.70	1.091	27.60	1.087
SBH51-LP_E-D28-__-BK	28/56	27.00	1.063	29.50	1.161	28.70	1.130	28.60	1.126
SBH51-LP_E-D29-__-BK	29/58	28.00	1.102	30.50	1.201	29.70	1.169	29.60	1.165
SBH51-LP_E-D30-__-BK	30/60	29.00	1.142	31.50	1.240	30.70	1.209	30.60	1.205
SBH51-LP_E-D31-__-BK	31/62	30.00	1.181	32.50	1.280	31.70	1.248	31.60	1.244
SBH51-LP_E-D32-__-BK	32/64	31.00	1.220	33.50	1.319	32.70	1.287	32.60	1.283
SBH51-LP_E-D33-__-BK	33/66	32.00	1.260	34.50	1.358	33.70	1.327	33.60	1.323
SBH51-LP_E-D34-__-BK	34/68	33.00	1.299	35.50	1.398	34.70	1.366	34.60	1.362
SBH51-LP_E-D35-__-BK	35/70	34.00	1.339	36.50	1.437	35.70	1.406	35.60	1.402
SBH51-LP_E-D36-__-BK	36/72	35.00	1.378	37.50	1.476	36.70	1.445	36.60	1.441
SBH51-LP_E-D37-__-BK	37/74	36.00	1.417	38.50	1.516	37.70	1.484	37.60	1.480
SBH51-LP_E-D38-__-BK	38/76	37.00	1.457	39.50	1.555	38.70	1.524	38.60	1.520
SBH51-LP_E-D39-__-BK	39/78	38.00	1.496	40.50	1.594	39.70	1.563	39.60	1.559
SBH51-LP_E-D40-__-BK	40/80	39.00	1.535	41.50	1.634	40.70	1.602	40.60	1.598
SBH51-LP_E-D41-__-BK	41/82	40.00	1.575	42.50	1.673	41.70	1.642	41.60	1.638
SBH51-LP_E-D42-__-BK	42/84	41.00	1.614	43.50	1.713	42.70	1.681	42.60	1.677
SBH51-LP_E-D43-__-BK	43/86	42.00	1.654	44.50	1.752	43.70	1.720	43.60	1.717
SBH51-LP_E-D44-__-BK	44/88	43.00	1.693	45.50	1.791	44.70	1.760	44.60	1.756
SBH51-LP_E-D45-__-BK	45/90	44.00	1.732	46.50	1.831	45.70	1.799	45.60	1.795
SBH51-LP_E-D46-__-BK	46/92	45.00	1.772	47.50	1.870	46.70	1.839	46.60	1.835
SBH51-LP_E-D47-__-BK	47/94	46.00	1.811	48.50	1.909	47.70	1.878	47.60	1.874
SBH51-LP_E-D48-__-BK	48/96	47.00	1.850	49.50	1.949	48.70	1.917	48.60	1.913
SBH51-LP_E-D49-__-BK	49/98	48.00	1.890	50.50	1.988	49.70	1.957	49.60	1.953
SBH51-LP_E-D50-__-BK	50/100	49.00	1.929	51.50	2.028	50.70	1.996	50.60	1.992

Sullins Headers



**.050" [1.27 mm] Contact Centers, Male Header  
Dip Solder/Right Angle/SMT**

**SPECIFICATIONS**

- Insulator Material: Nylon 9T
- Contact Material: Brass
- Plating: Overall Gold Flash
- 1 amp current rating per contact
- UL Flammability Rating: 94V-O
- Stacker Options available - Consult factory



**TERMINATION TYPE**

**SINGLE READOUT**

**DUAL READOUT**

**STRAIGHT**

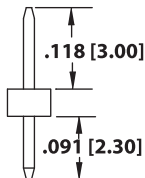

(VWVN)

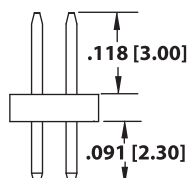

(VWVN)

**RIGHT ANGLE**

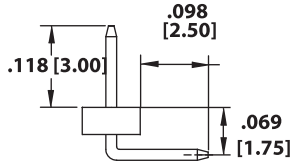

(VWCN)

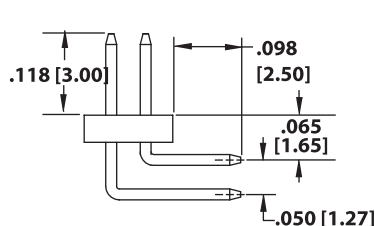

(MWCN)

**SURFACE MOUNT (SMT)**

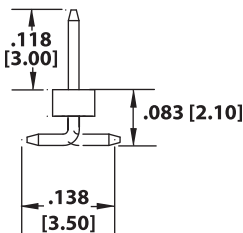

(VWTC, VWTD)

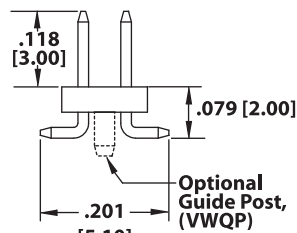

(VWQS), Without Guide Post  
(VWQP), With Guide Post

**PCB LAYOUT**

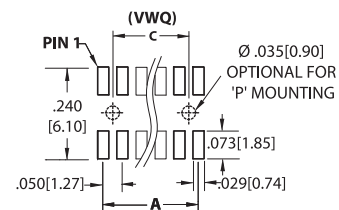
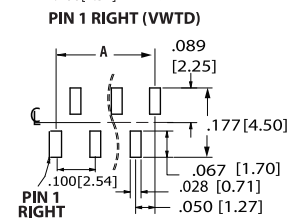
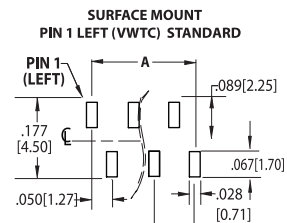
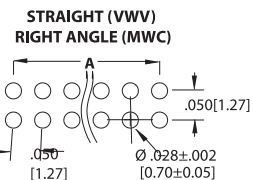
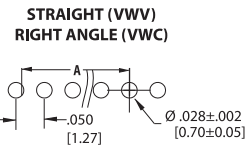

Sullins Headers

**MOUNTING STYLE**



No Mounting, (N)



SMT, Pin 1 Left (C)  
Standard

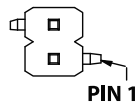
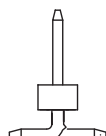

SMT, Pin 1 Right (D)  
Only Even Positions

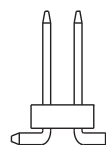

SMT, Without Guide Post (S)

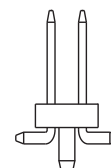

SMT, With Guide Post (P)



**.050" [1.27mm] Contact Centers, Male Header  
Dip Solder/Right Angle/SMT**

**PART NUMBER OPTIONS**

**G R P B xx 1 VVV N - RC**

**PLASTIC HOUSING**  
G = Nylon, 9-T

**CONTACT MATERIAL**  
R = Brass

**CONTACT FINISH - RoHS Compliant**  
P = Gold Flash Overall

**CONTACT CENTERS**  
B = .050" [1.27mm]

**NUMBER OF POSITIONS**

**Positions Available**  
2 Thru 50 = VWC, VWQ, VWT, VVV  
1 Thru 50 = MWC

**RoHS COMPLIANT**  
Consult Factory For Modifications

**MOUNTING STYLE**  
N = No Mounting  
C = Surface Mount, Pin 1 Left (Single Row Only)  
S = Surface Mount without Guide Pins (Dual Row Only)  
P = Surface Mount with Guide Posts (Dual Row Only)

**TERMINATION TYPE (Opposite Page)**  
VVV, VWC, MWC, VWT, VWQ

**NUMBER OF ROWS**  
1 = Single Row  
2 = Dual Row

**DIMENSIONS**

Dimensions in [ ] are in millimeters, all others are in inches.

**STRAIGHT (SHOWN) & RIGHT ANGLE**

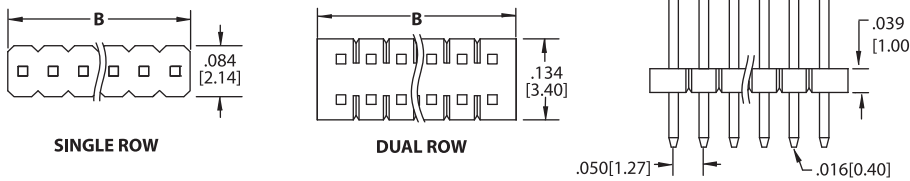

**SURFACE MOUNT, PIN 1 LEFT, SINGLE ROW (SHOWN)**

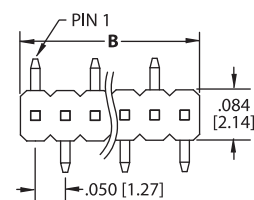

**SURFACE MOUNT, DUAL ROW**

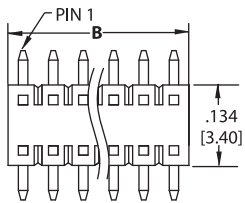

**WITHOUT GUIDE POST, (VWQ5)**

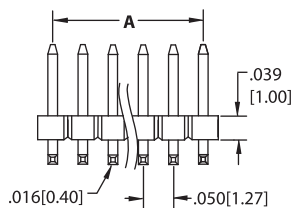

**WITH GUIDE POST, (VWQP)**

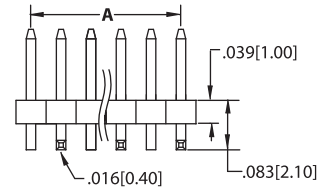
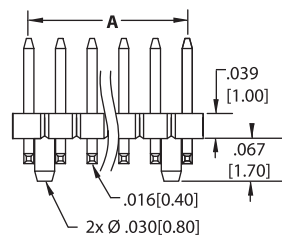

Positions	Number of Contacts Single/Dual	DIMENSION A		DIMENSION B		DIMENSION C	
		Inches	[mm]	Inches	[mm]	Inches	[mm]
01	01/02	.000	0.00	.050	1.27		
02	02/04	.050	1.27	.100	2.54		
03	03/06	.100	2.54	.150	3.81	.050	1.27
04	04/08	.150	3.81	.200	5.08	.100	2.54
05	05/10	.200	5.08	.250	6.35	.150	3.81
06	06/12	.250	6.35	.300	7.62	.200	5.08
07	07/14	.300	7.62	.350	8.89	.250	6.35
08	08/16	.350	8.89	.400	10.16	.300	7.62
09	09/18	.400	10.16	.450	11.43	.350	8.89
10	10/20	.450	11.43	.500	12.70	.400	10.16
11	11/22	.500	12.70	.550	13.97	.450	11.43
12	12/24	.550	13.97	.600	15.24	.500	12.70
13	13/26	.600	15.24	.650	16.51	.550	13.97
14	14/28	.650	16.51	.700	17.78	.600	15.24
15	15/30	.700	17.78	.750	19.05	.650	16.51
16	16/32	.750	19.05	.800	20.32	.700	17.78
17	17/34	.800	20.32	.850	21.59	.750	19.05
18	18/36	.850	21.59	.900	22.86	.800	20.32
19	19/38	.900	22.86	.950	24.13	.850	21.59
20	20/40	.950	24.13	1.000	25.40	.900	22.86
21	21/42	1.000	25.40	1.050	26.67	.950	24.13
22	22/44	1.050	26.67	1.100	27.94	1.000	25.40
23	23/46	1.100	27.94	1.150	29.21	1.050	26.67
24	24/48	1.150	29.21	1.200	30.48	1.100	27.94
25	25/50	1.200	30.48	1.250	31.75	1.150	29.21

Positions	Number of Contacts Single/Dual	DIMENSION A		DIMENSION B		DIMENSION C	
		Inches	[mm]	Inches	[mm]	Inches	[mm]
26	26/52	1.250	31.75	1.300	33.02	1.200	30.48
27	27/54	1.300	33.02	1.350	34.29	1.250	31.75
28	28/56	1.350	34.29	1.400	35.56	1.300	33.02
29	29/58	1.400	35.56	1.450	36.83	1.350	34.29
30	30/60	1.450	36.83	1.500	38.10	1.400	35.56
31	31/62	1.500	38.10	1.550	39.37	1.450	36.83
32	32/64	1.550	39.37	1.600	40.64	1.500	38.10
33	33/66	1.600	40.64	1.650	41.91	1.550	39.37
34	34/68	1.650	41.91	1.700	43.18	1.600	40.64
35	35/70	1.700	43.18	1.750	44.45	1.650	41.91
36	36/72	1.750	44.45	1.800	45.72	1.700	43.18
37	37/74	1.800	45.72	1.850	46.99	1.750	44.45
38	38/76	1.850	46.99	1.900	48.26	1.800	45.72
39	39/78	1.900	48.26	1.950	49.53	1.850	46.99
40	40/80	1.950	49.53	2.000	50.80	1.900	48.26
41	41/82	2.000	50.80	2.050	52.07	1.950	49.53
42	42/84	2.050	52.07	2.100	53.34	2.000	50.80
43	43/86	2.100	53.34	2.150	54.61	2.050	52.07
44	44/88	2.150	54.61	2.200	55.88	2.100	53.34
45	45/90	2.200	55.88	2.250	57.15	2.150	54.61
46	46/92	2.250	57.15	2.300	58.42	2.200	55.88
47	47/94	2.300	58.42	2.350	59.69	2.250	57.15
48	48/96	2.350	59.69	2.400	60.96	2.300	58.42
49	49/98	2.400	60.96	2.450	62.23	2.350	59.69
50	50/100	2.450	62.23	2.500	63.50	2.400	60.96



# .050" [1.27 mm] Contact Centers, Female Header Dip Solder/Right Angle/SMT

## SPECIFICATIONS

- Insulator Material: L.C.P.
- Contact Material: Phosphor Bronze
- Plating: Overall Gold Flash
- 1 amp current rating per contact
- UL Flammability Rating: 94V-0

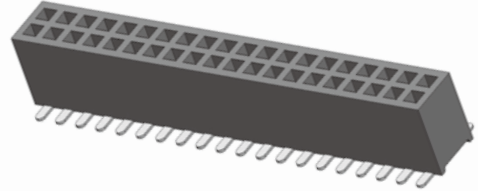

## TERMINATION TYPE

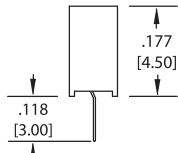

**SINGLE ROW,  
STRAIGHT  
(NFFN)**

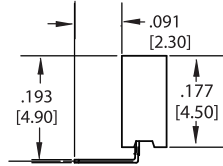

**SINGLE ROW,  
RIGHT ANGLE  
(NGCN)**

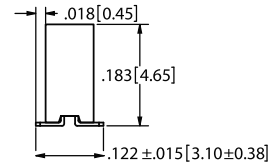

**SINGLE ROW,  
SMT  
(NFSC, NFSD)**

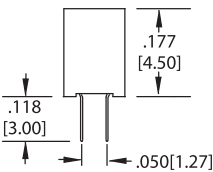

**DUAL ROW,  
STRAIGHT  
(CFFN)**

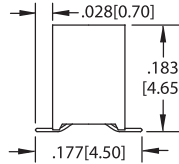

**DUAL ROW,  
SMT Without Guide Posts  
(NFSS)**

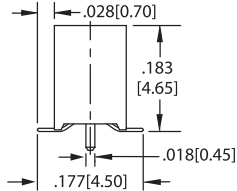

**DUAL ROW,  
SMT With Guide Posts  
(NFSP)**

## PCB LAYOUT

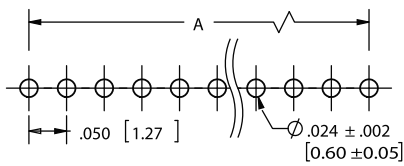

**(NFFN, NGCN)**

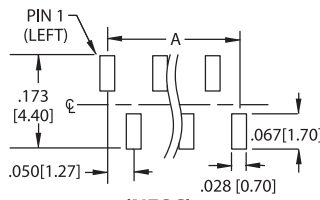

**(NFSC)**

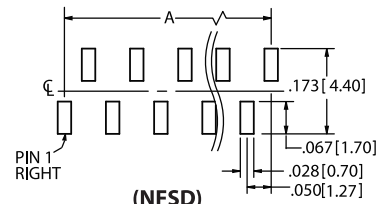

**(NFSD)**

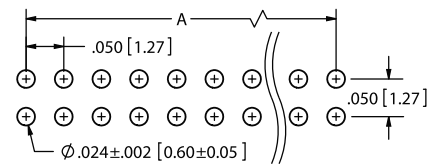

**(CFFN)**

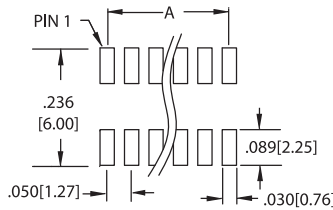

**(NFSS)**

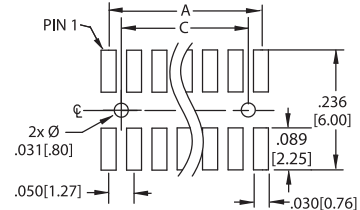

**(NFSP)**

## MOUNTING STYLE

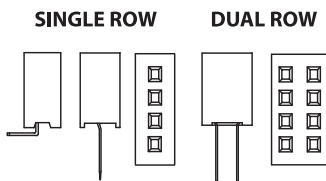

**NO MOUNTING  
(N)**

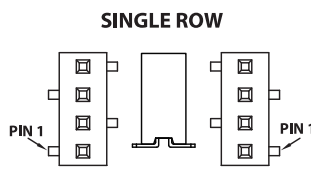

**SMT, Pin 1 Left (C)    SMT, Pin 1 Right (D)**

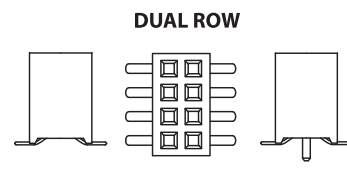

**SMT Without Guide Post (S)    SMT With Guide Post (P)**

Sullins Headers



**.050" [1.27 mm] Contact Centers, Female Header  
Dip Solder/Right Angle/SMT**

**PART NUMBER OPTIONS**

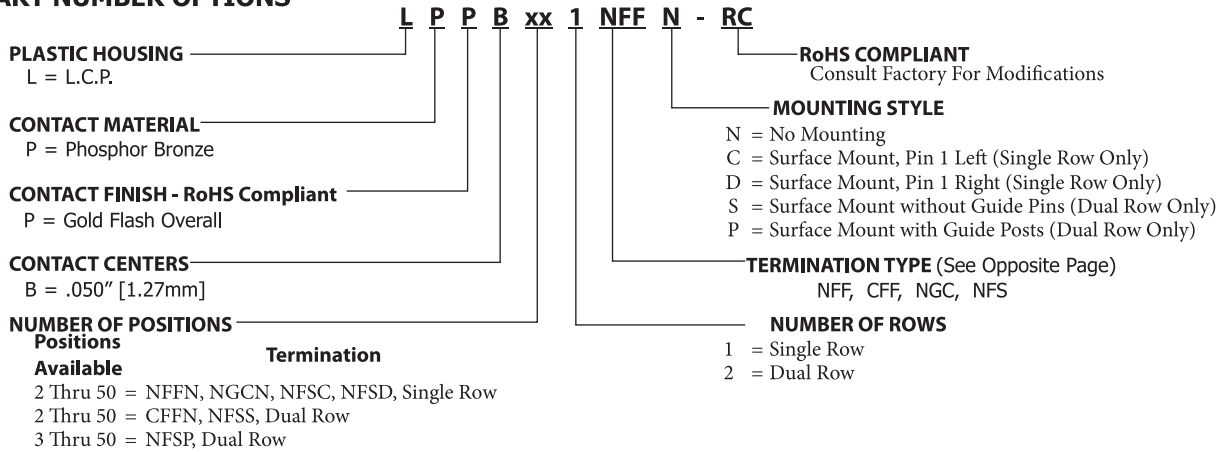

**DIMENSIONS**

Dimensions in [ ] are in millimeters, all others are in inches.

**STRAIGHT (shown) & RIGHT ANGLE**

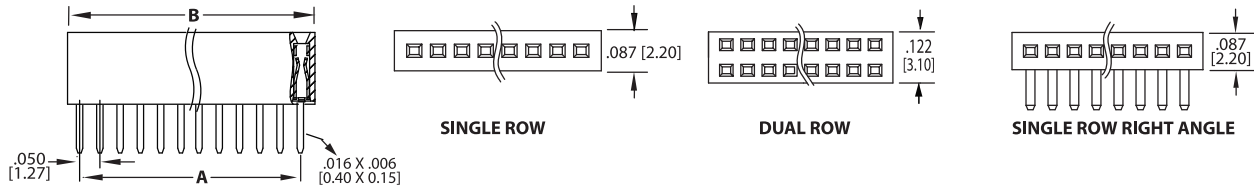

**SMT with and without guide post  
(with guide post shown- dual row only)**

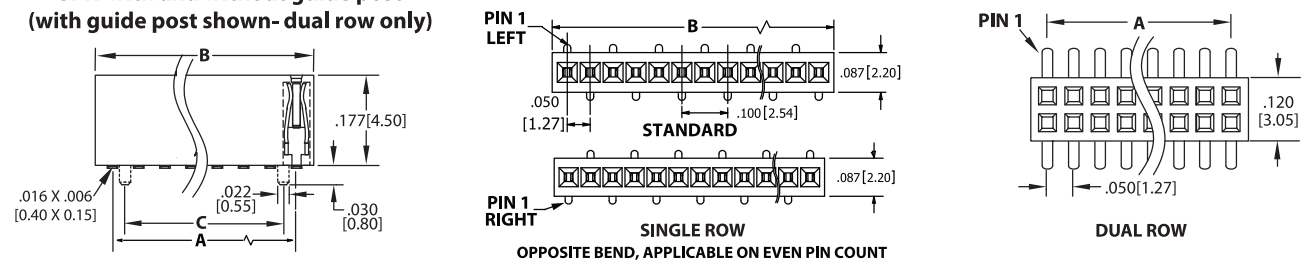

Positions	Number of Contacts Single/Dual	DIMENSION A		DIMENSION B		DIMENSION C		Positions	Number of Contacts Single/Dual	DIMENSION A		DIMENSION B		DIMENSION C	
		Inches	[mm]	Inches	[mm]	Inches	[mm]			Inches	[mm]	Inches	[mm]	Inches	[mm]
02	2/4	.050	1.27	.115	2.92			26	26/52	1.250	31.75	1.315	33.40	1.200	30.48
03	3/6	.100	2.54	.165	4.19	.050	1.27	27	27/54	1.300	33.02	1.365	34.67	1.250	31.75
04	4/8	.150	3.81	.215	5.46	.100	2.54	28	28/56	1.350	34.29	1.415	35.94	1.300	33.02
05	5/10	.200	5.08	.265	6.73	.150	3.81	29	29/58	1.400	35.56	1.465	37.21	1.350	34.29
06	6/12	.250	6.35	.315	8.00	.200	5.08	30	30/60	1.450	36.83	1.515	38.48	1.400	35.56
07	7/14	.300	7.62	.365	9.27	.250	6.35	31	31/62	1.500	38.10	1.565	39.75	1.450	36.83
08	8/16	.350	8.89	.415	10.54	.300	7.62	32	32/64	1.550	39.37	1.615	41.02	1.500	38.10
09	9/18	.400	10.16	.465	11.81	.350	8.89	33	33/66	1.600	40.64	1.665	42.29	1.550	39.37
10	10/20	.450	11.43	.515	13.08	.400	10.16	34	34/68	1.650	41.91	1.715	43.56	1.600	40.64
11	11/22	.500	12.70	.565	14.35	.450	11.43	35	35/70	1.700	43.18	1.765	44.83	1.650	41.91
12	12/24	.550	13.97	.615	15.62	.500	12.70	36	36/72	1.750	44.45	1.815	46.10	1.700	43.18
13	13/26	.600	15.24	.665	16.89	.550	13.97	37	37/74	1.800	45.72	1.865	47.37	1.750	44.45
14	14/28	.650	16.51	.715	18.16	.600	15.24	38	38/76	1.850	46.99	1.915	48.64	1.800	45.70
15	15/30	.700	17.78	.765	19.43	.650	16.51	39	39/78	1.900	48.26	1.965	49.91	1.850	46.99
16	16/32	.750	19.05	.815	20.70	.700	17.78	40	40/80	1.950	49.53	2.015	51.18	1.900	48.26
17	17/34	.800	20.32	.865	21.97	.750	19.05	41	41/82	2.000	50.80	2.065	52.45	1.950	49.53
18	18/36	.850	21.59	.915	23.24	.800	20.32	42	42/84	2.050	52.07	2.115	53.72	2.000	50.80
19	19/38	.900	22.86	.965	24.51	.850	21.59	43	43/86	2.100	53.34	2.165	54.99	2.050	52.07
20	20/40	.950	24.13	1.015	25.78	.900	22.86	44	44/88	2.150	54.61	2.215	56.26	2.100	53.34
21	21/42	1.000	25.40	1.065	27.05	.950	24.13	45	45/90	2.200	55.88	2.265	57.53	2.150	54.61
22	22/44	1.050	26.67	1.115	28.32	1.000	25.40	46	46/92	2.250	57.15	2.315	58.80	2.200	55.88
23	23/46	1.100	27.94	1.165	29.59	1.050	26.67	47	47/94	2.300	58.42	2.365	60.07	2.250	57.15
24	24/48	1.150	29.21	1.215	30.86	1.100	27.94	48	48/96	2.350	59.69	2.415	61.34	2.300	58.42
25	25/50	1.200	30.48	1.265	32.13	1.150	29.21	49	49/98	2.400	60.96	2.465	62.61	2.350	59.69
								50	50/100	2.450	62.23	2.515	63.88	2.400	60.96



**.050" [1.27mm] Contact Centers, Top/Bottom Entry SMT Female Headers**

**SPECIFICATIONS**

- Insulator Material: Nylon 6T, UL 94V-0
- Contact Resistance: 20m OHMs Max.
- Current Rating: 1 AMP per contact
- Dielectric WithStanding: 500 V AC.
- Insulation Resistance: 5000 Mega OHMS Min.
- Operating Temperature: - 40° C to + 105° C
- Processing Temperature: 230° C for 60 seconds Max.

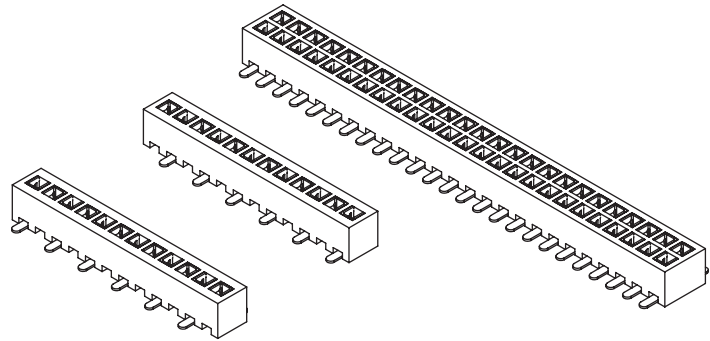

**RECOMMENDED PCB LAYOUT**

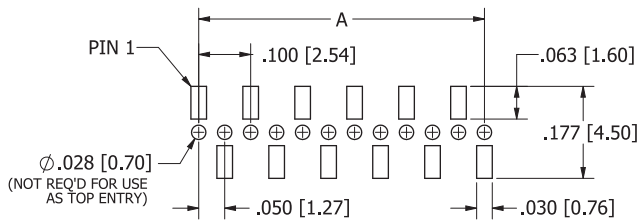

**SFM230-NPPB-S\_\_-SC-BK**

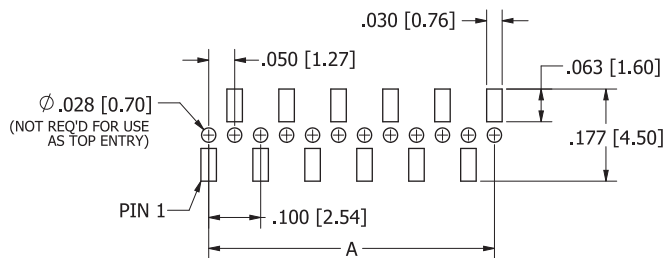

**SFM230-NPPB-S\_\_-SD-BK**

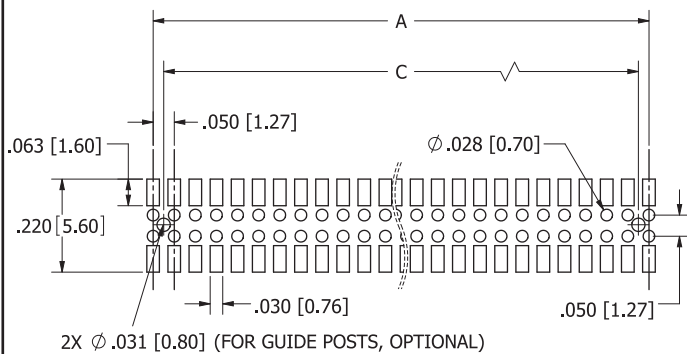

**SFM230-NPPB-D\_\_-S-BK**

**DIMENSIONS**

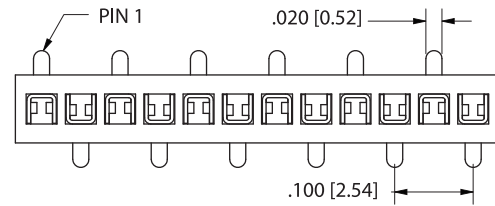

**SFM230-NPPB-S\_\_-SC-BK**  
(STANDARD)

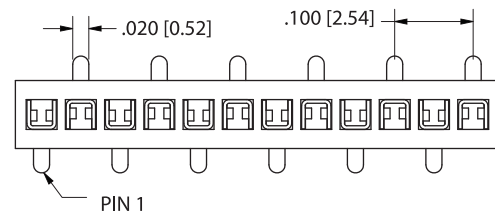

**SFM230-NPPB-S\_\_-SD-BK**  
(OPPOSITE BEND, APPLICABLE ON EVEN PIN COUNTS)

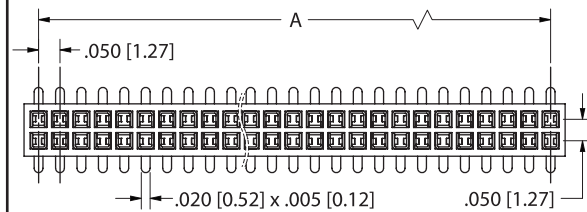

**SFM230-NPPB-D\_\_-S-BK**

Sullins Headers



**.050" [1.27mm] Contact Centers, Top/Bottom Entry SMT Female Headers**

**PART NUMBER OPTIONS**

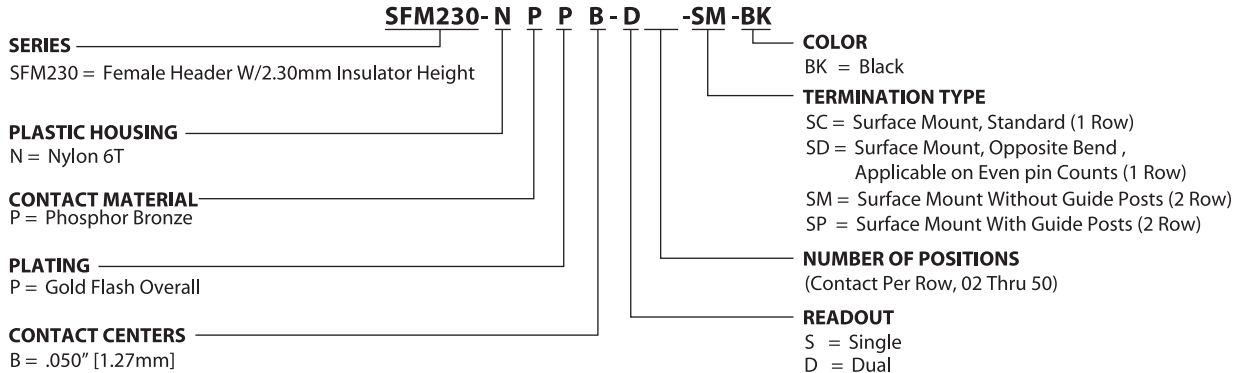

**DIMENSIONS**

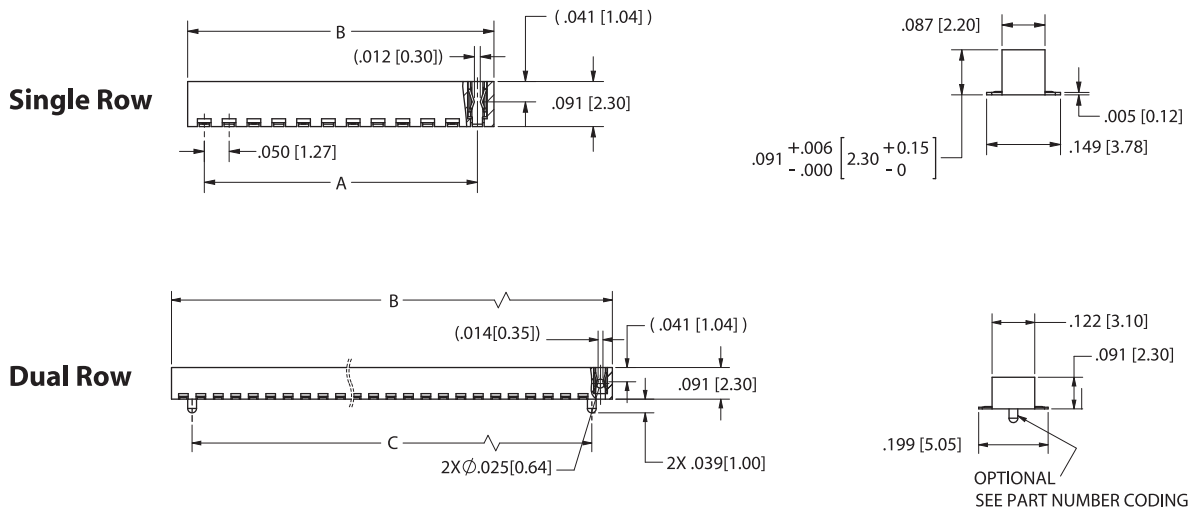

No. of Contacts Single/Dual	A		B		C	
	inch	mm	inch	mm	inch	mm
02/04*	0.050	1.27	0.118	2.99	N/A	N/A
03/06	0.100	2.54	0.168	4.26	0.050	1.27
04/08	0.150	3.81	0.218	5.53	0.100	2.54
05/10	0.200	5.08	0.268	6.80	0.150	3.81
06/12	0.250	6.35	0.318	8.07	0.200	5.08
07/14	0.300	7.62	0.368	9.34	0.250	6.35
08/16	0.350	8.89	0.418	10.61	0.300	7.62
09/18	0.400	10.16	0.468	11.88	0.350	8.89
10/20	0.450	11.43	0.518	13.15	0.400	10.16
11/22	0.500	12.70	0.568	14.42	0.450	11.43
12/24	0.550	13.97	0.618	15.69	0.500	12.70
13/26	0.600	15.24	0.668	16.96	0.550	13.97
14/28	0.650	16.51	0.718	18.23	0.600	15.24
15/30	0.700	17.78	0.768	19.50	0.650	16.51
16/32	0.750	19.05	0.818	20.77	0.700	17.78
17/34	0.800	20.32	0.868	22.04	0.750	19.05
18/36	0.850	21.59	0.918	23.31	0.800	20.32
19/38	0.900	22.86	0.968	24.58	0.850	21.59
20/40	0.950	24.13	1.018	25.85	0.900	22.86
21/42	1.000	25.40	1.068	27.12	0.950	24.13
22/44	1.050	26.67	1.118	28.39	1.000	25.40
23/46	1.100	27.94	1.168	29.66	1.050	26.67
24/48	1.150	29.21	1.218	30.93	1.100	27.94
25/50	1.200	30.48	1.268	32.20	1.150	29.21
26/52	1.250	31.75	1.318	33.47	1.200	30.48

No. of Contacts Single/Dual	A		B		C	
	inch	mm	inch	mm	inch	mm
27/54	1.300	33.02	1.368	34.74	1.250	31.75
28/56	1.350	34.29	1.418	36.01	1.300	33.02
29/58	1.400	35.56	1.468	37.28	1.350	34.29
30/60	1.450	36.83	1.518	38.55	1.400	35.56
31/62	1.500	38.10	1.568	39.82	1.450	36.83
32/64	1.550	39.37	1.618	41.09	1.500	38.10
33/66	1.600	40.64	1.668	42.36	1.550	39.37
34/68	1.650	41.91	1.718	43.63	1.600	40.64
35/70	1.700	43.18	1.768	44.90	1.650	41.91
36/72	1.750	44.45	1.818	46.17	1.700	43.18
37/74	1.800	45.72	1.868	47.44	1.750	44.45
38/76	1.850	46.99	1.918	48.71	1.800	45.72
39/78	1.900	48.26	1.968	49.98	1.850	46.99
40/80	1.950	49.53	2.018	51.25	1.900	48.26
41/82	2.000	50.80	2.068	52.52	1.950	49.53
42/84	2.050	52.07	2.118	53.79	2.000	50.80
43/86	2.100	53.34	2.168	55.06	2.050	52.07
44/88	2.150	54.61	2.218	56.33	2.100	53.34
45/90	2.200	55.88	2.268	57.60	2.150	54.61
46/92	2.250	57.15	2.318	58.87	2.200	55.88
47/94	2.300	58.42	2.368	60.14	2.250	57.15
48/96	2.350	59.69	2.418	61.41	2.300	58.42
49/98	2.400	60.96	2.468	62.68	2.350	59.69
50/100	2.450	62.23	2.518	63.95	2.400	60.96

\* Not available with guide posts.



**.050" [1.27mm] Contact Centers, Shrouded (Box) Headers/Straight/Right Angle/SMT  
With or Without Post- SBH Series  
Mates with SFH31 series (See opposite page)**

**SPECIFICATIONS**

- Polarizing Notch
- Operating Temperature: - 40° C to + 85° C
- Processing Temperature: 230° C for 60 seconds Max.  
(260° C, 10 seconds)
- UL Flammability Rating: 94V-0
- Voltage Rating: 20m OHMs Max.
- Current Rating: 1 AMP per contact
- Voltage Drop: AC 500 V.
- Insulation Resistance: 1000 Mega OHMS

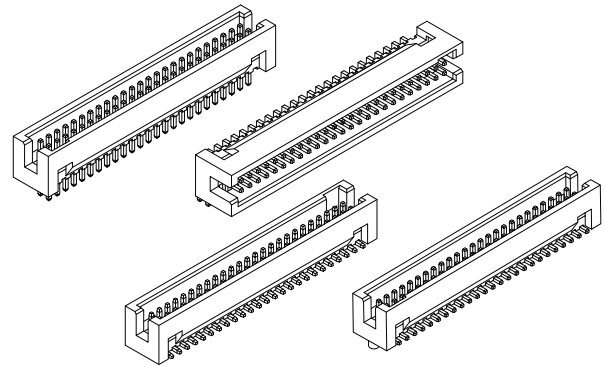

**PART NUMBER OPTIONS**

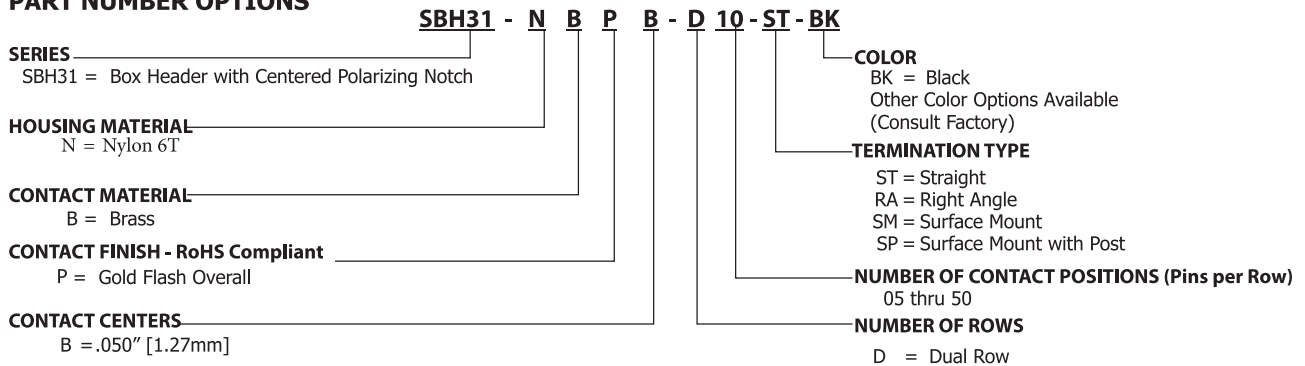

**DIMENSIONS** For complete drawings, go to [www.sullinscorp.com](http://www.sullinscorp.com) or e-mail [techsupport@sullinscorp.com](mailto:techsupport@sullinscorp.com)

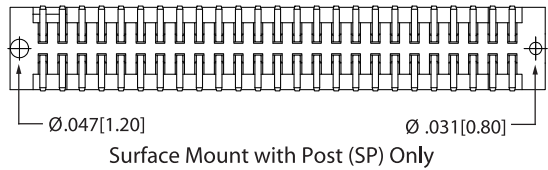
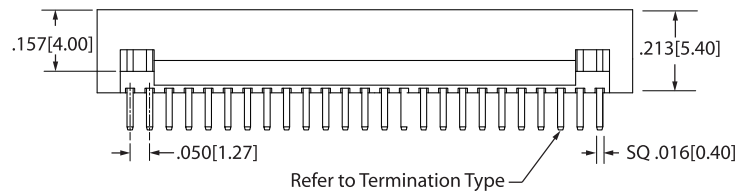
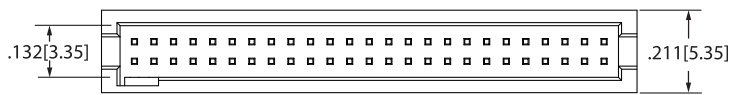
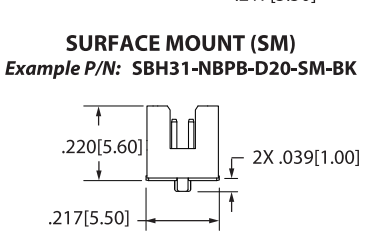
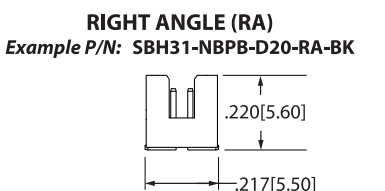
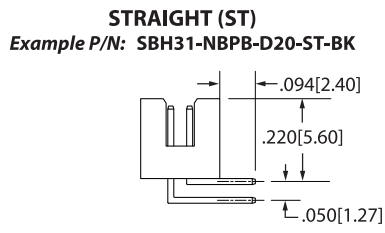
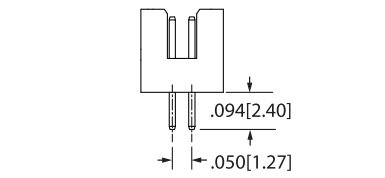

Sullins Headers



**.050" [1.27mm] Contact Centers, Female Header, SMT with Posts- SFH Series**  
*Mates with SBH31 series (See opposite page)*

**SPECIFICATIONS**

Operating Temperature: - 40° C to + 85° C  
 Processing Temperature: 230° C for 60 seconds Max.  
 (260° C, 10 seconds)  
 UL Flammability Rating: 94V-0  
 Contact Resistance: 20m OHMs Max.  
 Current Rating: 1 AMP per contact  
 Dielectric Withstanding: 500 VAC  
 Insulation Resistance: 1000 Mega OHMS

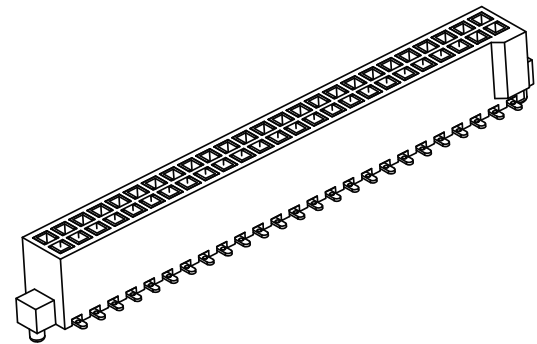

**PART NUMBER OPTIONS**

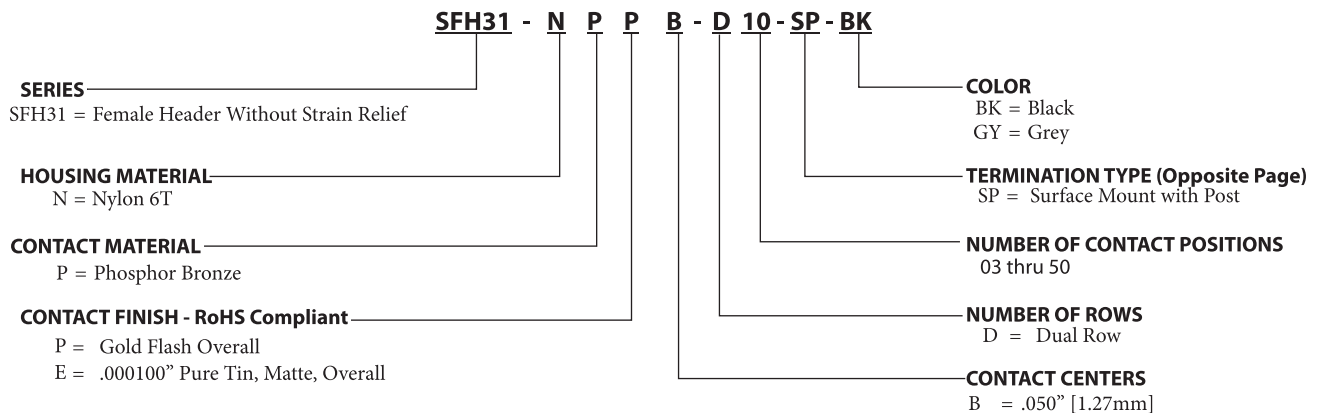

**DIMENSIONS** For complete drawings, go to [www.sullinscorp.com](http://www.sullinscorp.com) or e-mail [techsupport@sullinscorp.com](mailto:techsupport@sullinscorp.com)

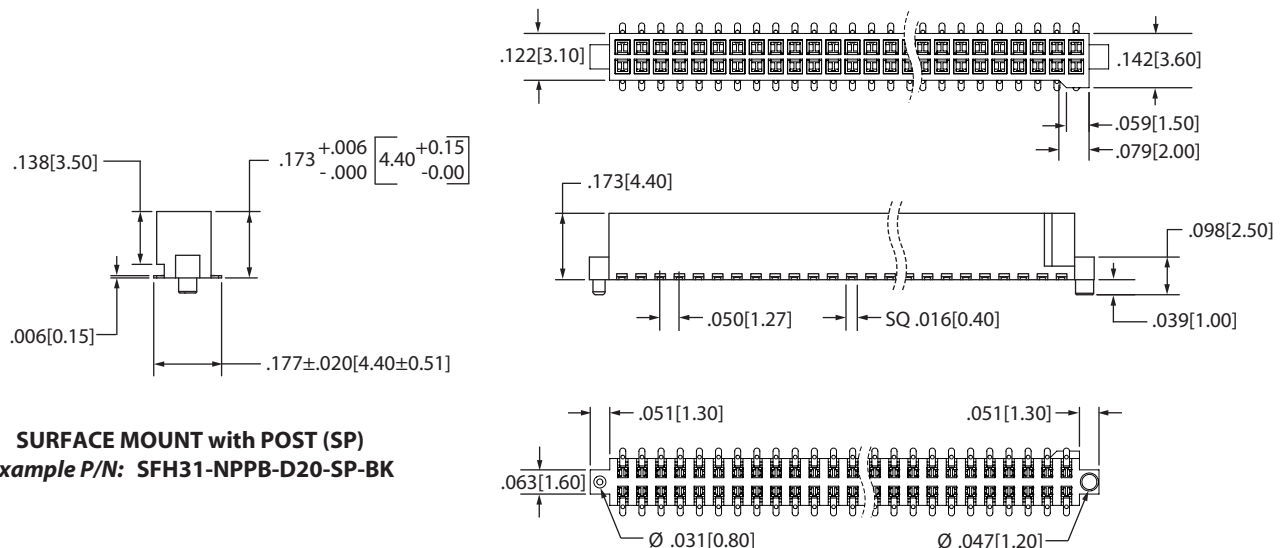

Sullins Headers



**.050" [1.27mm] Contact Centers Shrouded (Box) Headers, .100" [2.54] Row Spacing**  
**Straight/Right Angle/SMT With or Without Post- SBH Series**  
**Mates with SFH41 series (See opposite page)**

**SPECIFICATIONS**

- Centered Polarizing Notch
- Operating Temperature: - 40° C to + 85° C
- Processing Temperature: 230° C for 60 seconds Max.  
(2600 C, 10 seconds)
- UL Flammability Rating: 94V-0
- Voltage Rating: 20m OHMs Max.
- Current Rating: 1 AMP per contact
- Voltage Drop: AC 500 V.
- Insulation Resistance: 1000 Mega OHMS

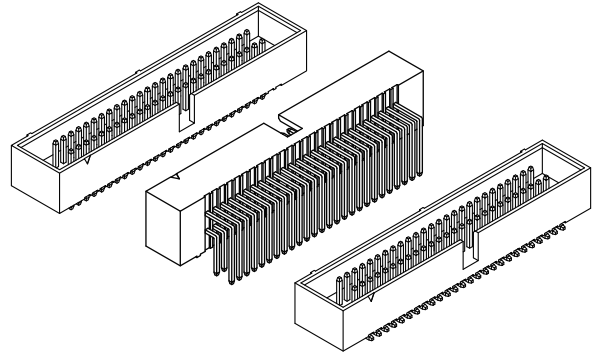

**PART NUMBER OPTIONS**

**SBH41 - N B P B - D 10 - ST - BK**

**SERIES**  
SBH41 = Box Header with Centered Polarizing Notch

**HOUSING MATERIAL**  
N = Nylon 6T

**CONTACT MATERIAL**  
B = Brass

**CONTACT FINISH - RoHS Compliant**  
P = Gold Flash Overall

**CONTACT CENTERS**  
B = .050" [1.27mm]

**COLOR**  
BK = Black  
Other Color Options Available  
(Consult Factory)

**TERMINATION TYPE**  
ST = Straight  
RA = Right Angle  
SM = Surface Mount  
SP = Surface Mount with Post

**NUMBER OF CONTACT POSITIONS (Pins per Row)**  
05 thru 50

**NUMBER OF ROWS**  
D = Dual Row

**DIMENSIONS** For complete drawings, go to [www.sullinscorp.com](http://www.sullinscorp.com) or e-mail [techsupport@sullinscorp.com](mailto:techsupport@sullinscorp.com)

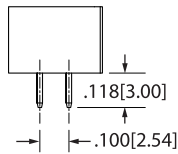

**STRAIGHT (ST)**

Example P/N: SBH41-NBPP-D20-ST-BK

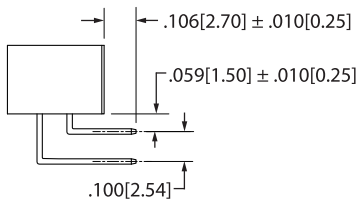

**RIGHT ANGLE (RA)**

Example P/N: SBH41-NBPP-D20-RA-BK

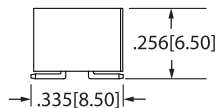

**SURFACE MOUNT (SM)**

Example P/N: SBH41-NBPP-D20-SM-BK

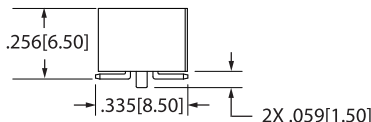

**SURFACE MOUNT with POST (SP)**

Example P/N: SBH41-NBPP-D20-SP-BK

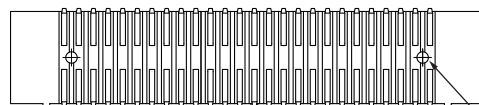
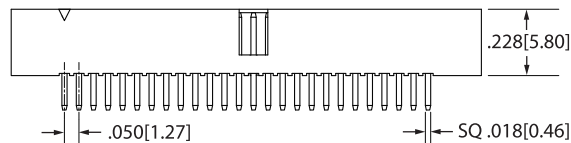
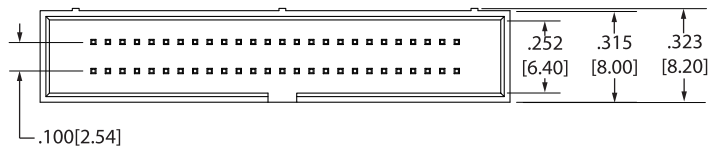

Surface Mount with Post (SP) Only

Sullins Headers



**.050" [1.27mm] Contact Centers, IDC Sockets, .100" [2.54] Row Spacing  
Insulation Displacement With or Without Strain Relief - SFH Series  
Mates with SBH41 series (See opposite page)**

**SPECIFICATIONS**

- Centered Polarizing Key
- Operating Temperature: - 40° C to + 105° C
- UL Flammability Rating: 94V-0
- Contact Resistance: 30 MEGA OHMS Max.
- Current Rating: 1 AMP per contact
- Dielectric Withstanding: 500 VAC R.M.S. for One Minute
- Insulation Resistance: 500 Mega OHMS



**PART NUMBER OPTIONS**

**SFH41 - P P P B - D 10 - ID - BK**

**SERIES**  
SFH41 = IDC Socket Without Strain Relief, .050" [1.27mm] Contact Centers  
SFH413 = IDC Socket With Strain Relief, .050" [1.27mm] Contact Centers

**HOUSING MATERIAL**  
P = PBT

**CONTACT MATERIAL**  
P = Phosphor Bronze

**CONTACT FINISH - RoHS Compliant**  
P = Gold Flash Overall  
E = .000100" Pure Tin, Matte, Overall  
V = Gold Flash on Contact Surface, Nickel Underplate on Tails

**COLOR**  
BK = Black  
GY = Grey

**TERMINATION TYPE (Opposite Page)**  
ID = Insulation Displacement

**NUMBER OF CONTACT POSITIONS**  
05, 08, 10, 13, 15, 17, 20, 25, 30, 34, 40, 50

**NUMBER OF ROWS**  
D = Dual Row

**CONTACT CENTERS**  
B = .050" [1.27mm]

**DIMENSIONS** For complete drawings, go to [www.sullincorp.com](http://www.sullincorp.com) or e-mail [techsupport@sullincorp.com](mailto:techsupport@sullincorp.com)

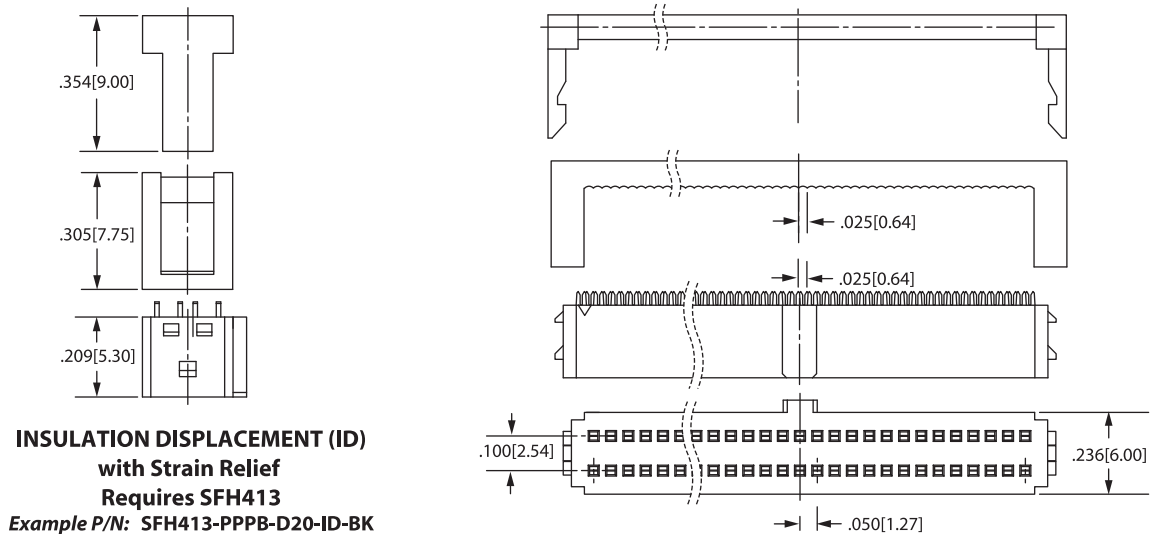
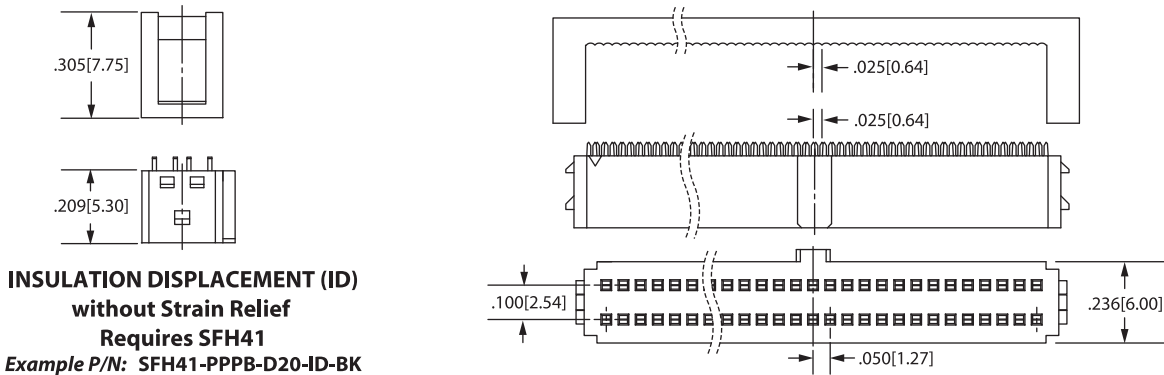

Sullins Headers



**.079" [2 mm] Contact Centers, Male Header  
Dip Solder/Right Angle/SMT**

**SPECIFICATIONS**

- 1 amp current rating per contact (4 amp for 4 row only)
- UL Flammability Rating: 94V-0
- Insulator: Nylon 6-T
- Contact Material: Brass
- Stacker Options available - Consult Factory



**JUMPERS**

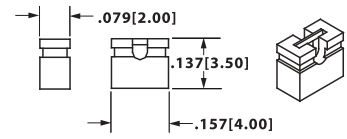

PART NUMBER:  
SPN02SYBN-RC (GOLD FLASH)  
STN02SYBN-RC (TIN PLATE)

**READOUT**

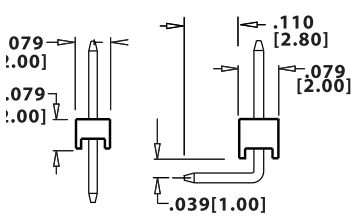

SINGLE (1)

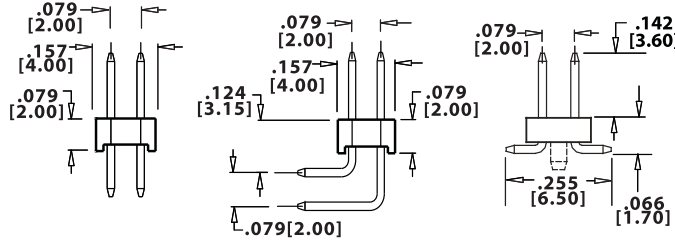

DUAL (2)

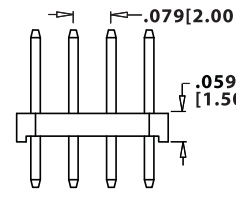

QUAD (4)

**TERMINATION TYPE**

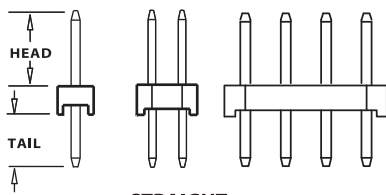

STRAIGHT

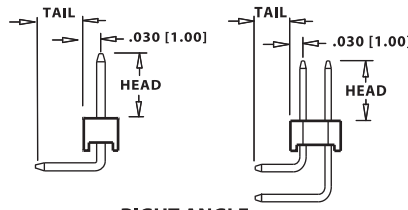

RIGHT ANGLE

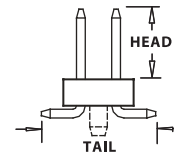

SMT

P/N CODE	ROWS	TERM	HEAD	TAIL	P/N CODE	ROWS	TERM	HEAD	TAIL	P/N CODE	ROWS	TERM	HEAD	TAIL
PAE	1	STRAIGHT	.142" [3.60]	.110" [2.80]	PAR	1	RIGHT ANGLE	.142" [3.60]	.110" [2.80]					
PAE	2	STRAIGHT	.142" [3.60]	.110" [2.80]	PAR	2	RIGHT ANGLE	.142" [3.60]	.110" [2.80]	MAM	2	SMT	.142" [3.60]	.256" [6.50]
RCC	4	STRAIGHT	.173" [4.40]	.094" [2.40]										

**MOUNTING STYLE**



No Mounting-Default Standard (N)

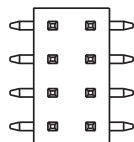

Two Row SMT, Without Guide Post (S)

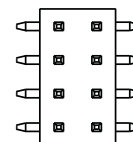

Two Row SMT, With Guide Post (P)

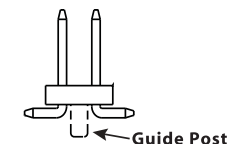

Sullins Headers



**.079" [2 mm] Contact Centers, Male Header  
Dip Solder/Right Angle/SMT**

**PART NUMBER OPTIONS**

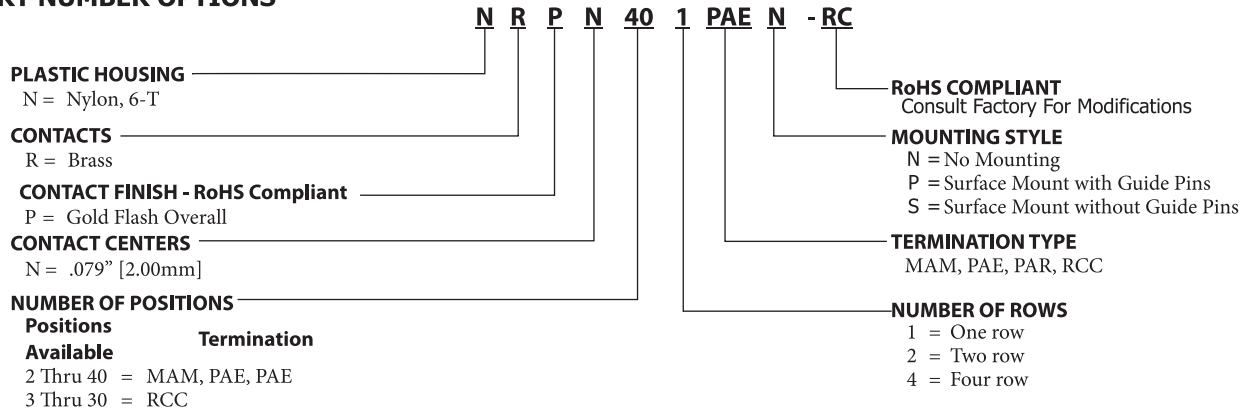

**DIMENSIONS**

Dimensions in [ ] are in millimeters, all others are in inches.

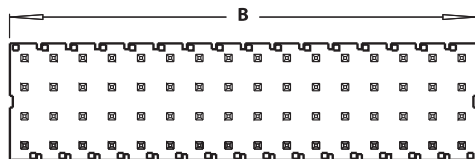
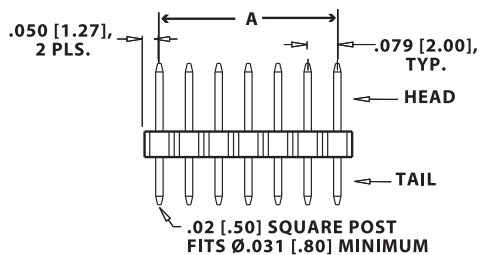

**QUAD READOUT,  
STRAIGHT TAIL SHOWN**

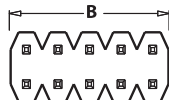

**DUAL READOUT,  
STRAIGHT TAIL SHOWN**

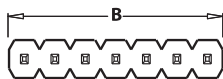

**SINGLE READOUT,  
STRAIGHT TAIL SHOWN**

PART NUMBER	NUMBER OF CONTACTS SINGLE/DUAL/QUAD	DIMENSION A		DIMENSION B	
		INCHES	[MM]	INCHES	[MM]
_RPN02 ___ N-RC	02/04	0.079	2.00	0.157	4.00
_RPN03 ___ N-RC	03/06/12	0.157	4.00	0.236	6.00
_RPN04 ___ N-RC	04/08/16	0.236	6.00	0.315	8.00
_RPN05 ___ N-RC	05/10/20	0.315	8.00	0.394	10.00
_RPN06 ___ N-RC	06/12/24	0.394	10.00	0.472	12.00
_RPN07 ___ N-RC	07/14/28	0.472	12.00	0.551	14.00
_RPN08 ___ N-RC	08/16/32	0.551	14.00	0.630	16.00
_RPN09 ___ N-RC	09/18/36	0.630	16.00	0.709	18.00
_RPN10 ___ N-RC	10/20/40	0.709	18.00	0.787	20.00
_RPN11 ___ N-RC	11/22/44	0.787	20.00	0.866	22.00
_RPN12 ___ N-RC	12/24/48	0.866	22.00	0.945	24.00
_RPN13 ___ N-RC	13/26/52	0.945	24.00	1.024	26.00
_RPN14 ___ N-RC	14/28/56	1.024	26.00	1.102	28.00
_RPN15 ___ N-RC	15/30/60	1.102	28.00	1.181	30.00
_RPN16 ___ N-RC	16/32/64	1.181	30.00	1.260	32.00
_RPN17 ___ N-RC	17/34/68	1.260	32.00	1.339	34.00
_RPN18 ___ N-RC	18/36/72	1.339	34.00	1.417	36.00
_RPN19 ___ N-RC	19/38/76	1.417	36.00	1.496	38.00
_RPN20 ___ N-RC	20/40/80	1.496	38.00	1.575	40.00
_RPN21 ___ N-RC	21/42/84	1.575	40.00	1.654	42.00
_RPN22 ___ N-RC	22/44/88	1.654	42.00	1.732	44.00
_RPN23 ___ N-RC	23/46/92	1.732	44.00	1.811	46.00
_RPN24 ___ N-RC	24/48/96	1.811	46.00	1.890	48.00
_RPN25 ___ N-RC	25/50/100	1.890	48.00	1.969	50.00
_RPN26 ___ N-RC	26/52/104	1.969	50.00	2.047	52.00
_RPN27 ___ N-RC	27/54/108	2.047	52.00	2.126	54.00
_RPN28 ___ N-RC	28/56/112	2.126	54.00	2.205	56.00
_RPN29 ___ N-RC	29/58/116	2.205	56.00	2.283	58.00
_RPN30 ___ N-RC	30/60/120	2.283	58.00	2.362	60.00
_RPN31 ___ N-RC	31/62	2.362	60.00	2.441	62.00
_RPN32 ___ N-RC	32/64	2.441	62.00	2.520	64.00
_RPN33 ___ N-RC	33/66	2.520	64.00	2.598	66.00
_RPN34 ___ N-RC	34/68	2.598	66.00	2.677	68.00
_RPN35 ___ N-RC	35/70	2.677	68.00	2.756	70.00
_RPN36 ___ N-RC	36/72	2.756	70.00	2.835	72.00
_RPN37 ___ N-RC	37/74	2.835	72.00	2.913	74.00
_RPN38 ___ N-RC	38/76	2.913	74.00	2.992	76.00
_RPN39 ___ N-RC	39/78	2.992	76.00	3.071	78.00
_RPN40 ___ N-RC	40/80	3.071	78.00	3.150	80.00

Sullins Headers



**.079" [2 mm] Contact Centers, Female Header**  
**Dip Solder/Right Angle/SMT**

**SPECIFICATIONS**

- 1 amp current rating per contact
- UL Flammability Rating: 94V-0
- Insulator: Black Thermoplastic Polyester/Nylon 6-T
- Contact Material: Phosphor Bronze

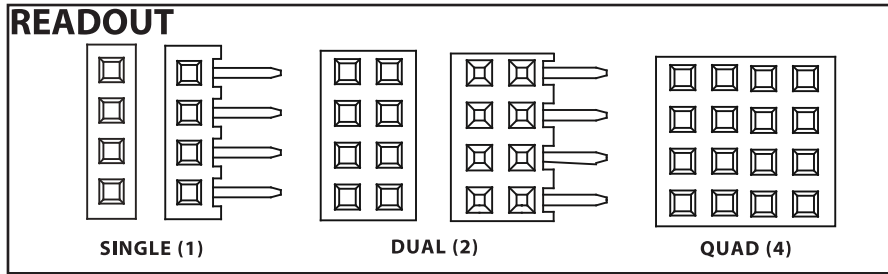
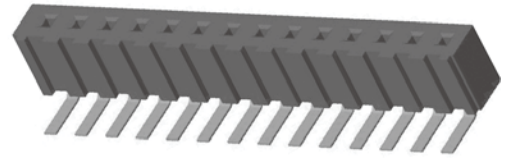

**TERMINATION TYPE**

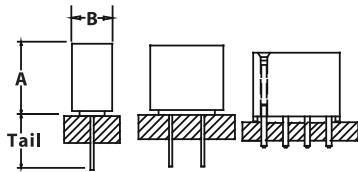

**STRAIGHT**

P/N CODE	ROWS	TERM	A	B	TAIL
BFC	1	STRAIGHT	.173 [4.40]	.094 [2.40]	.094 [2.40]
AFC	2	STRAIGHT	.170 [4.30]	.157 [4.00]	.094 [2.40]
AFE	2	STRAIGHT	1.70 [4.30]	.157 [4.00]	.110 [2.80]
EFC	4	STRAIGHT	.248 [6.30]	.315 [8.00]	.094 [2.40]

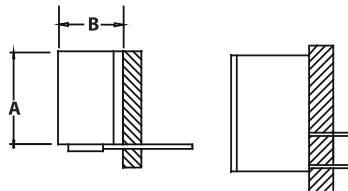

**RIGHT ANGLE**

P/N CODE	ROWS	TERM	A	B	TAIL
FGG	1	RIGHT ANGLE	.169 [4.30]	.110 [2.80]	.122 [3.10]
FJF	2	RIGHT ANGLE	.285 [7.20]	.191 [4.85]	.118 [3.00]

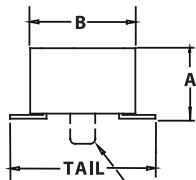

**SMT**

P/N CODE	ROWS	TERM	A	B	TAIL
BFL	1	SMT	.181 [4.60]	.094 [2.40]	.157 [4.00]
GFN	2	SMT	.110 [2.80]	.165 [4.20]	.228 [5.80]
GHN	Replaced by GFN				
FFK	2	SMT	.173 [4.40]	.157 [4.00]	.228 [5.80]

Refer to Mounting Style

**MOUNTING STYLE**



**No Mounting-Standard (N)**

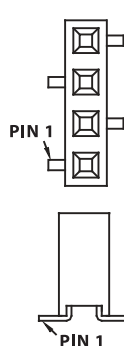

**One Row SMT, Pin 1 Left (C)**

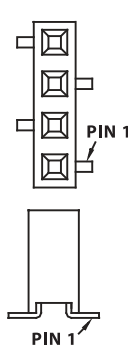

**One Row SMT, Pin 1 Right (D)**

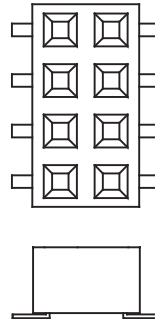

**Two Row SMT, Without Guide Posts (S)**

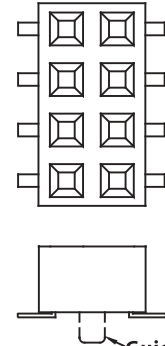

**Two Row SMT, With Guide Post (P)**

Sullins Headers



**.079" [2 mm] Contact Centers, Female Header  
Dip Solder/Right Angle/SMT**

**PART NUMBER OPTIONS**

**NP P N 40 1 BFC N - RC**

**PLASTIC HOUSING**  
NP = Nylon 6-T/Phosphor Bronze

**CONTACT FINISH - RoHS Compliant**  
Contact Termination  
P = Gold Flash Gold Flash (For 1 and 2 Row)  
R = .000020" Gold .000100" Tin (For 4 row)

**CONTACT CENTERS**  
N = .079" [2.00mm]

**NUMBER OF POSITIONS**  
Positions Available Termination  
2 Thru 40 = AFC, AFE, BFL, FFK, FGG, FJF  
3 Thru 40 = BFC, GFN  
5 Thru 30 = EFC

**NUMBER OF ROWS (Opposite Page)**  
1 = One Row  
2 = Two Row  
4 = Four Row

**RoHS COMPLIANT**  
Consult Factory For Modifications

**MOUNTING STYLE**  
N = No Mounting  
C = SMT, Single row female, pin 1 Left  
D = SMT, Single row female, pin 1 Right  
P = Surface mount with guide pins  
S = Surface mount without guide pins

**TERMINATION TYPE (Opposite Page)**  
AFC = Thru Hole Top Entry  
AFE = Thru Hole Top Entry/Closed Bottom  
BFC = Thru Hole Top Entry  
EFC = Thru Hole Top Entry  
FGG = R/A Top Entry  
FJF = R/A Top Entry  
BFL = SMT Top Entry  
FFK = SMT Top Entry  
GFN = SMT Top/Bottom Entry  
GHN = SMT Replaced by GFN

**DIMENSIONS**

Dimensions in [ ] are in millimeters, all others are in inches.

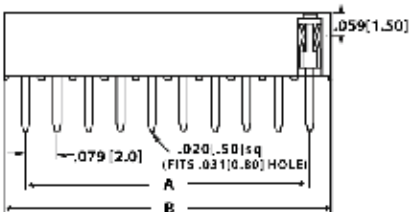

**SINGLE READOUT,  
STRAIGHT TAIL SHOWN**

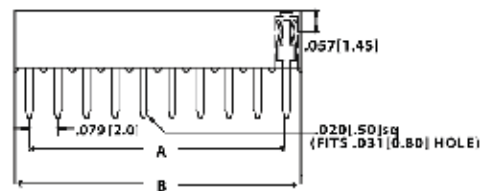

**DUAL READOUT,  
STRAIGHT TAIL SHOWN**

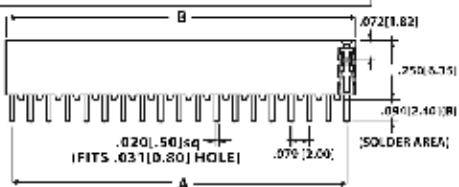

**QUAD READOUT,  
STRAIGHT TAIL SHOWN**

PART NUMBER	NUMBER OF CONTACTS SINGLE/DUAL/ QUAD	CENTER TO CENTER LENGTH [A]		OVERALL LENGTH [B]	
		INCHES	[MM]	INCHES	[MM]
PN02	N-RC 02/04	0.079	2.00	0.157	4.00
PN03	N-RC 03/06	0.157	4.00	0.236	6.00
PN04	N-RC 04/08	0.236	6.00	0.315	8.00
PN05	N-RC 05/10/20	0.315	8.00	0.394	10.00
PN06	N-RC 06/12/24	0.394	10.00	0.472	12.00
PN07	N-RC 07/14/28	0.472	12.00	0.551	14.00
PN08	N-RC 08/16/32	0.551	14.00	0.630	16.00
PN09	N-RC 09/18/36	0.630	16.00	0.709	18.00
PN10	N-RC 10/20/40	0.709	18.00	0.787	20.00
PN11	N-RC 11/22/44	0.787	20.00	0.866	22.00
PN12	N-RC 12/24/48	0.866	22.00	0.945	24.00
PN13	N-RC 13/26/52	0.945	24.00	1.024	26.00
PN14	N-RC 14/28/54	1.024	26.00	1.102	28.00
PN15	N-RC 15/30/60	1.102	28.00	1.181	30.00
PN16	N-RC 16/32/64	1.181	30.00	1.260	32.00
PN17	N-RC 17/34/68	1.260	32.00	1.339	34.00
PN18	N-RC 18/36/72	1.339	34.00	1.417	36.00
PN19	N-RC 19/38/76	1.417	36.00	1.496	38.00
PN20	N-RC 20/40/80	1.496	38.00	1.575	40.00
PN21	N-RC 21/42/84	1.575	40.00	1.654	42.00
PN22	N-RC 22/44/88	1.654	42.00	1.732	44.00
PN23	N-RC 23/46/92	1.732	44.00	1.811	46.00
PN24	N-RC 24/48/96	1.811	46.00	1.890	48.00
PN25	N-RC 25/50/100	1.890	48.00	1.969	50.00
PN26	N-RC 26/52/104	1.969	50.00	2.047	52.00
PN27	N-RC 27/54/108	2.047	52.00	2.126	54.00
PN28	N-RC 28/56/112	2.126	54.00	2.205	56.00
PN29	N-RC 29/58/116	2.205	56.00	2.283	58.00
PN30	N-RC 30/60/120	2.283	58.00	2.362	60.00
PN31	N-RC 31/62	2.362	60.00	2.441	62.00
PN32	N-RC 32/64	2.441	62.00	2.520	64.00
PN33	N-RC 33/66	2.520	64.00	2.598	66.00
PN34	N-RC 34/68	2.598	66.00	2.677	68.00
PN35	N-RC 35/70	2.677	68.00	2.756	70.00
PN36	N-RC 36/72	2.756	70.00	2.835	72.00
PN37	N-RC 37/74	2.835	72.00	2.913	74.00
PN38	N-RC 38/76	2.913	74.00	2.992	76.00
PN39	N-RC 39/78	2.992	76.00	3.071	78.00
PN40	N-RC 40/80	3.071	78.00	3.150	80.00



### .079" [2.00mm] Contact Centers, Top/Bottom Entry SMT Female Headers

#### SPECIFICATIONS

- Insulator Material: Nylon 6T, UL 94V-0
- Contact Resistance: 20m OHMs Max.
- Current Rating: 2 AMPS per contact
- Dielectric WithStanding: 500 V AC.
- Insulation Resistance: 5000 Mega OHMS Min.
- Operating Temperature: - 40° C to + 105° C
- Processing Temperature: 230° C for 60 seconds Max.

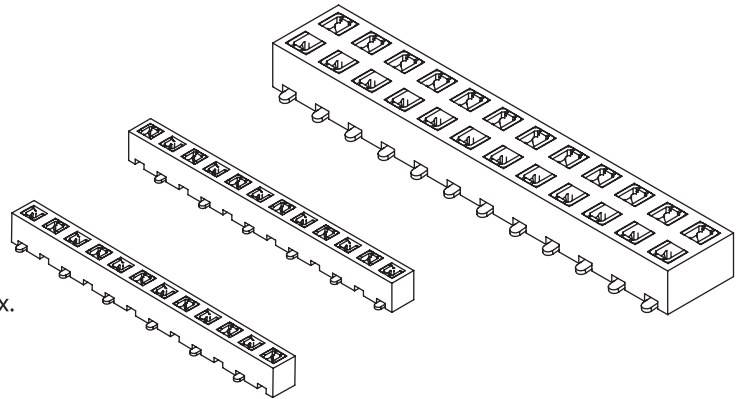

#### RECOMMENDED PCB LAYOUT

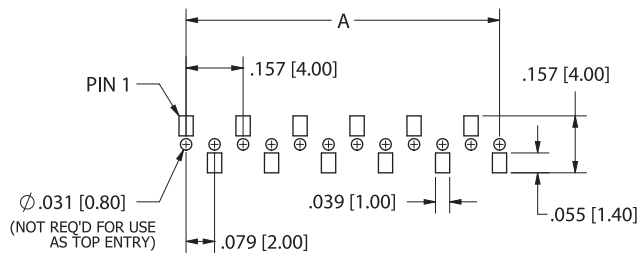

SFM230-NPPN-S\_\_-SC-BK

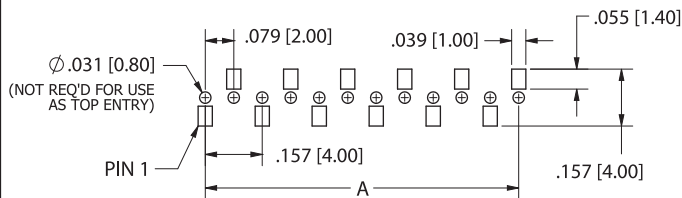

SFM230-NPPN-S\_\_-SD-BK

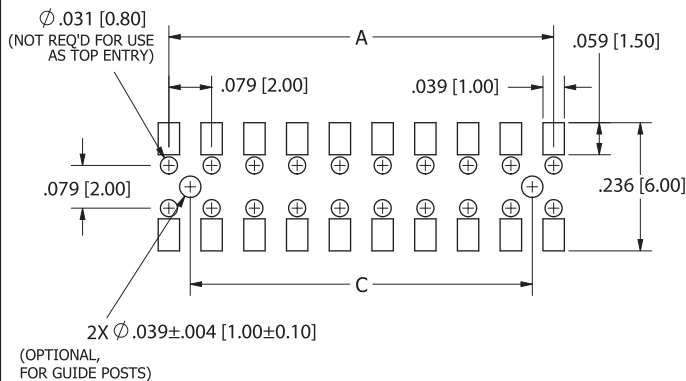

SFM230-NPPN-D\_\_-S-BK

#### DIMENSIONS

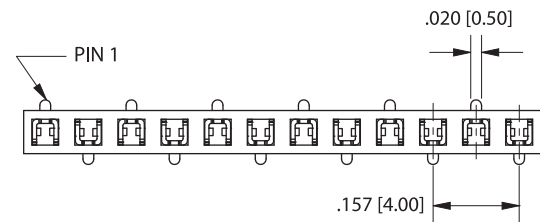

SFM230-NPPN-S\_\_-SC-BK  
(STANDARD)

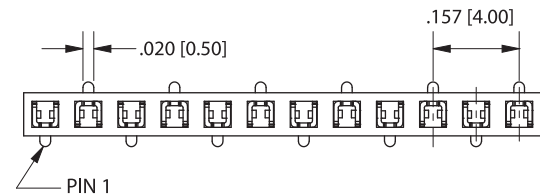

SFM230-NPPN-S\_\_-SD-BK  
(OPPOSITE BEND, APPLICABLE ON EVEN PIN COUNTS)

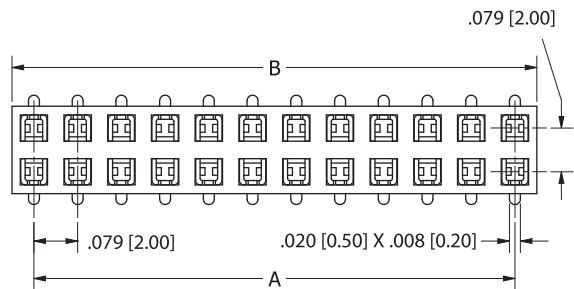

SFM230-NPPN-D\_\_-S-BK

Sullins Headers



**.079" [2.00mm] Contact Centers, Top/Bottom Entry SMT Female Headers**

**PART NUMBER OPTIONS**

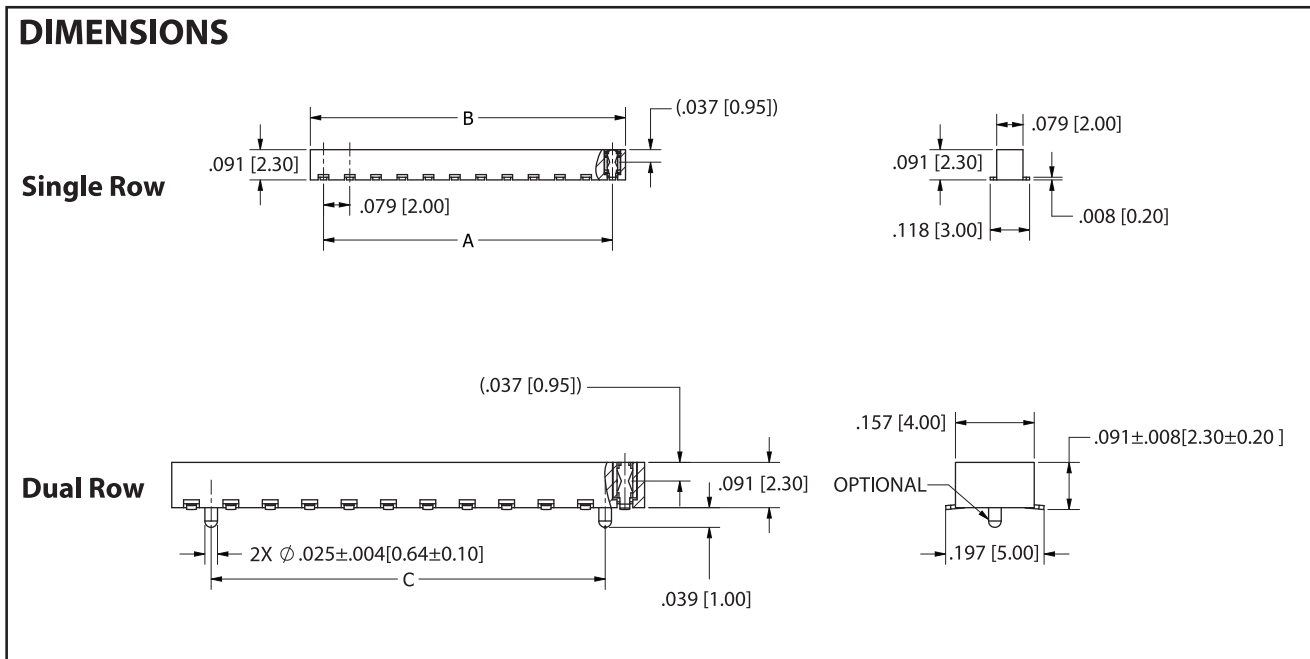
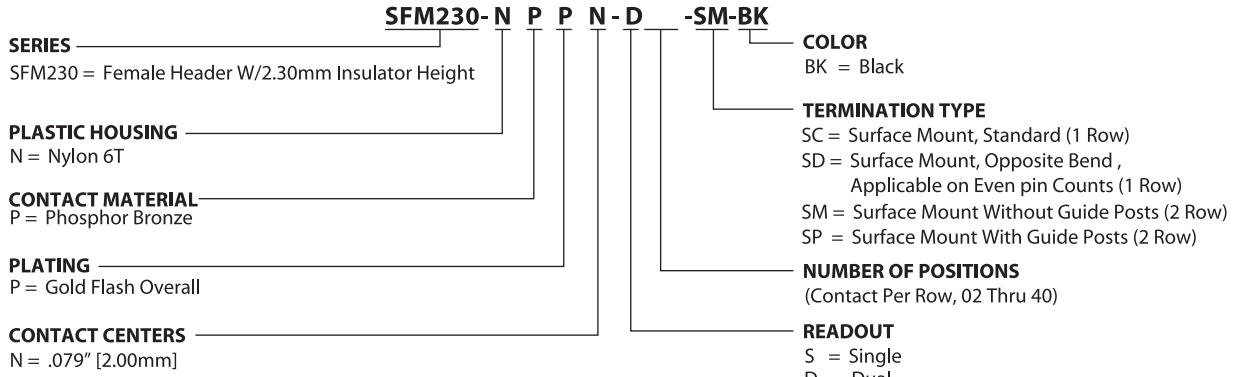

No. of Contacts Single/Dual	A		B		C		No. of Contacts Single/Dual	A		B		C	
	inch	mm	inch	mm	inch	mm		inch	mm	inch	mm	inch	mm
02/04*	0.079	2.00	0.157	4.00	N/A	N/A	22/44	1.654	42.00	1.732	44.00	1.575	40.00
03/06	0.157	4.00	0.236	6.00	0.079	2.00	23/46	1.732	44.00	1.811	46.00	1.654	42.00
04/08	0.236	6.00	0.315	8.00	0.157	4.00	24/48	1.811	46.00	1.890	48.00	1.732	44.00
05/10	0.315	8.00	0.394	10.00	0.236	6.00	25/50	1.890	48.00	1.969	50.00	1.811	46.00
06/12	0.394	10.00	0.472	12.00	0.315	8.00	26/52	1.969	50.00	2.047	52.00	1.890	48.00
07/14	0.472	12.00	0.551	14.00	0.394	10.00	27/54	2.047	52.00	2.126	54.00	1.969	50.00
08/16	0.551	14.00	0.630	16.00	0.472	12.00	28/56	2.126	54.00	2.205	56.00	2.047	52.00
09/18	0.630	16.00	0.709	18.00	0.551	14.00	29/58	2.205	56.00	2.283	58.00	2.126	54.00
10/20	0.709	18.00	0.787	20.00	0.630	16.00	30/60	2.283	58.00	2.362	60.00	2.205	56.00
11/22	0.787	20.00	0.866	22.00	0.709	18.00	31/62	2.362	60.00	2.441	62.00	2.283	58.00
12/24	0.866	22.00	0.945	24.00	0.787	20.00	32/64	2.441	62.00	2.520	64.00	2.362	60.00
13/26	0.945	24.00	1.024	26.00	0.866	22.00	33/66	2.520	64.00	2.598	66.00	2.441	62.00
14/28	1.024	26.00	1.102	28.00	0.945	24.00	34/68	2.598	66.00	2.677	68.00	2.520	64.00
15/30	1.102	28.00	1.181	30.00	1.024	26.00	35/70	2.677	68.00	2.756	70.00	2.598	66.00
16/32	1.181	30.00	1.260	32.00	1.102	28.00	36/72	2.756	70.00	2.835	72.00	2.677	68.00
17/34	1.260	32.00	1.339	34.00	1.181	30.00	37/74	2.835	72.00	2.913	74.00	2.756	70.00
18/36	1.339	34.00	1.417	36.00	1.260	32.00	38/76	2.913	74.00	2.992	76.00	2.835	72.00
19/38	1.417	36.00	1.496	38.00	1.339	34.00	39/78	2.992	76.00	3.071	78.00	2.913	74.00
20/40	1.496	38.00	1.575	40.00	1.417	36.00	40/80	3.071	78.00	3.150	80.00	2.992	76.00
21/42	1.575	40.00	1.654	42.00	1.496	38.00							

\* Not available with guide posts.



**.079" [2.00mm] Contact Centers, Shrouded (Box) Headers**  
**Straight/Right Angle/SMT - SBH Series**  
**Mates with SFH21 series (See opposite page)**

**SPECIFICATIONS**

- **Centered Polarizing Notch**
- Operating Temperature: - 40° C to + 85° C
- Processing Temperature: 230° C for 60 seconds Max. (260° C, 10 seconds)
- UL Flammability Rating: 94V-0
- Voltage Rating: 20m OHMs Max.
- Current Rating: 2 AMP per contact
- Voltage Drop: AC 500 V.
- Insulation Resistance: 1000 Mega OHMS

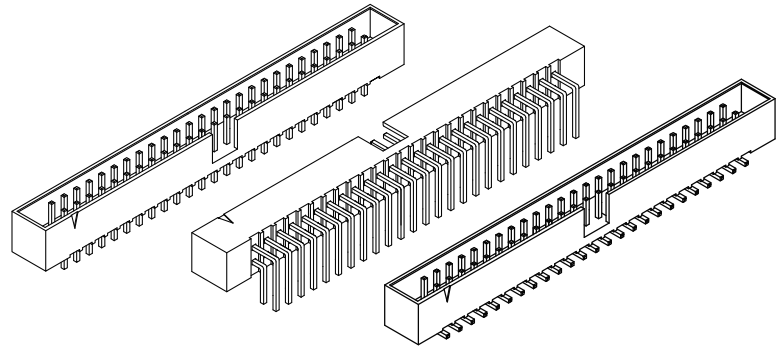

**PART NUMBER OPTIONS**

**SBH21 - N B P N - D 10 - ST - BK**

**SERIES** \_\_\_\_\_  
SBH21 = Box Header with Centered Polarizing Notch

**HOUSING MATERIAL** \_\_\_\_\_  
N = Nylon 6T

**CONTACT MATERIAL** \_\_\_\_\_  
B = Brass

**CONTACT FINISH - RoHS Compliant** \_\_\_\_\_  
P = Gold Flash Overall

**CONTACT CENTERS** \_\_\_\_\_  
N = .079" [2.00mm]

**COLOR** \_\_\_\_\_  
BK = Black  
Other Color Options Available (Consult Factory)

**TERMINATION TYPE** \_\_\_\_\_  
ST = Straight  
RA = Right Angle  
SM = Surface Mount

**NUMBER OF CONTACT POSITIONS (Pins per Row)** \_\_\_\_\_  
03 thru 20, 22, 25, 27, 28, 30, 31, 32, 34

**NUMBER OF ROWS** \_\_\_\_\_  
D = Dual Row

**DIMENSIONS** For complete drawings, go to [www.sullincorp.com](http://www.sullincorp.com) or e-mail [techsupport@sullincorp.com](mailto:techsupport@sullincorp.com)

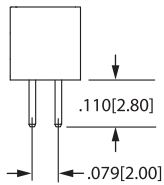

**STRAIGHT (ST)**

Example P/N: SBH21-NBPN-D20-ST-BK

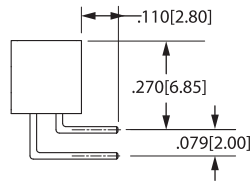
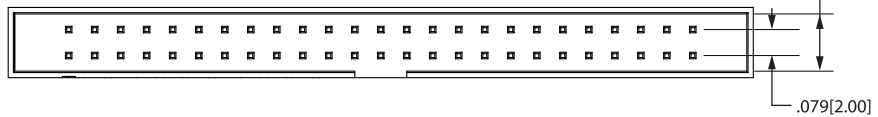

**RIGHT ANGLE (RA)**

Example P/N: SBH21-NBPN-D20-RA-BK

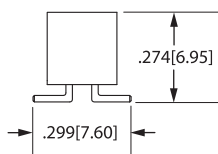
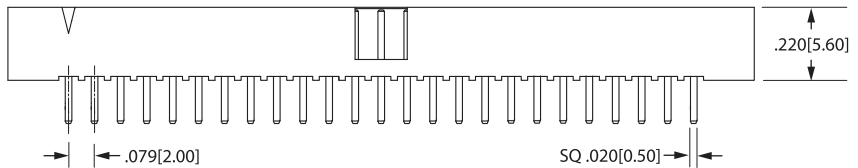

**SURFACE MOUNT (SM)**

Example P/N: SBH21-NBPN-D20-SM-BK



Sullins Headers



**.079" [2.00mm] Contact Centers, IDC Sockets, Insulation Displacement  
With or Without Strain Relief- SFH Series  
Mates with SBH21 series (See opposite page)**

**SPECIFICATIONS**

- **Centered Polarizing Key Optional**
- Operating Temperature: - 45° C to + 85° C
- UL Flammability Rating: 94V-0
- Current Rating: 1 AMP per contact
- Dielectric Withstanding: 500 VAC
- Insulation Resistance: 1000 Mega OHMS

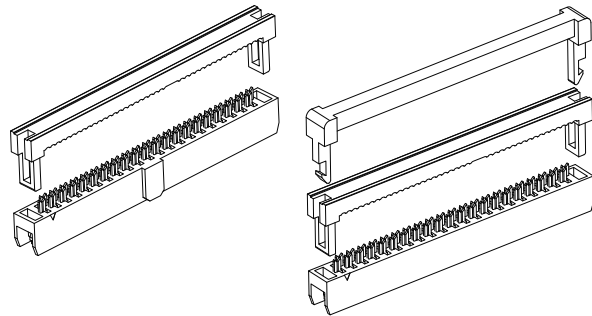

**PART NUMBER OPTIONS**

**SFH21 - P P P N - D 10 - ID - BK - M181**

**SERIES** \_\_\_\_\_  
SFH21 = IDC Socket Without Strain Relief  
SFH213 = IDC Socket With Strain Relief

**HOUSING MATERIAL** \_\_\_\_\_  
P = PBT

**CONTACT MATERIAL** \_\_\_\_\_  
P = Phosphor Bronze

**CONTACT FINISH - RoHS Compliant**  
P = Gold Flash Overall  
E = .000100" Pure Tin, Matte, Overall  
V = Gold Flash on Contact Surface, Nickel Underplate on Tails

**MODIFICATION (Omit for Standard)**  
M181 = Without Centered Polarizing Key

**COLOR**  
BK = Black  
GY = Grey

**TERMINATION TYPE (Opposite Page)**  
ID = Insulation Displacement

**NUMBER OF CONTACT POSITIONS**  
03 thru 13, 15, 17, 20, 22, 25, 30, 34(SFH21)  
05 thru 13, 15, 17, 20, 22, 25 (SFH213)

**NUMBER OF ROWS**  
D = Dual Row

**CONTACT CENTERS**  
N = .079" [2.00mm]

**DIMENSIONS** For complete drawings, go to [www.sullinscorp.com](http://www.sullinscorp.com) or e-mail [techsupport@sullinscorp.com](mailto:techsupport@sullinscorp.com)

**INSULATION DISPLACEMENT (ID) without Strain Relief, requires SFH21**

*Example P/N: SFH21-PPPN-D20-ID-BK*

Centered Polarizing Key Optional, Requires -M181 Modification to Remove

**-M181 Modification (No Centered Polarizing Key)**

---

**INSULATION DISPLACEMENT (ID) with Strain Relief, requires SFH213**

*Example P/N: SFH213-PPPN-D20-ID-BK*

Centered Polarizing Key Optional, Requires -M181 Modification to Remove

**-M181 Modification (No Centered Polarizing Key)**



**.100" [2.54 mm] Contact Centers, Male Breakaway Header  
Dip Solder/Right Angle/SMT**

**SPECIFICATIONS**

- 3 amp current rating per contact
- UL Flammability Rating: 94V-O
- Insulator: Polyester, PA9T
- Contact Material: Phosphor Bronze

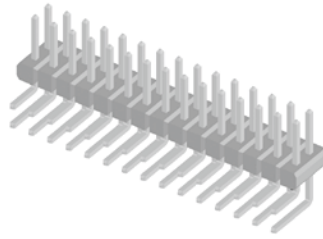

**JUMPERS** (see jumper pages for additional options)

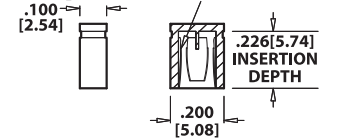

**PART NUMBER:**  
STC02SYAN (TIN PLATE)  
SPC02SYAN (GOLD FLASH)  
SSC02SYAN (0.000010" GOLD PLATE)

**TERMINATION TYPES  
STRAIGHT TERMINATIONS**

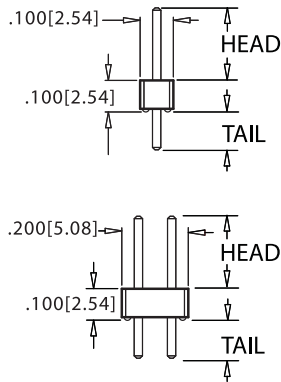

P/N CODE	HEAD DIMENSION	TAIL DIMENSION
AA	.230[5.84]	.120[3.05]
AB	.230[5.84]	.230[5.84]
AC	.230[5.84]	.320[8.13]
AD	.230[5.84]	.420[10.67]
AE	.230[5.84]	.520[13.21]
AF	.230[5.84]	.620[15.75]
AG	.230[5.84]	.720[18.29]
AH	.230[5.84]	.820[20.83]
AI*	.230[5.84]	.900[22.86]
AJ*	.230[5.84]	1.000[25.40]
AK*	.230[5.84]	.035[0.89]
FA	.318[8.08]	.120[3.05]
FB	.318[8.08]	.220[5.59]
FC	.318[8.08]	.320[8.13]
FD	.318[8.08]	.420[10.67]
FE	.318[8.08]	.520[13.21]
FF*	.318[8.08]	.620[15.75]
FG*	.318[8.08]	.710[18.29]
FH*	.318[8.08]	.810[20.83]
FI*	.318[8.08]	.910[23.37]
FJ*	.318[8.08]	.050[1.27]
ZA	.120[3.05]	.120[3.05]
ZB*	.120[3.05]	.095[2.41]
ZC	.120[3.05]	.260[6.60]
ZD	.120[3.05]	.610[15.49]
ZI*	.520[13.21]	.110[2.79]
ZJ*	.720[18.29]	.110[2.79]
ZO*	.820[20.83]	.110[2.79]
ZQ*	1.020[25.91]	.110[2.79]
ZR*	1.220[30.99]	.110[2.79]

\*Consult Factory for availability

**SMT TERMINATIONS**

Single Row with -M89 Modification Code

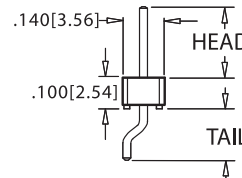

P/N CODE	HEAD DIMENSION	TAIL DIMENSION
BS	.230[5.84]	.180[4.57]
GS	.318[8.08]	.180[4.57]
ZC*	.120[3.05]	.180[4.57]
ZU*	.420[10.67]	.180[4.57]

\*Consult Factory for availability.

**SMT TERMINATIONS**

Single or Dual Row with -M30 Modification Code

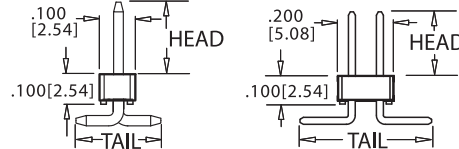

P/N CODE	HEAD DIMENSION	SINGLE ROW TAIL DIMENSION	DUAL ROW TAIL DIMENSION
AB	.230[5.84]	.320[8.13]	.420[10.67]
FB	.318[8.08]	.300[7.62]	.400[10.16]
ZS*	.120[3.05]	.200[5.08]	.300[7.62]
ZT*	.420[10.67]	.200[5.08]	.300[7.62]

\*Consult Factory for availability

**RIGHT ANGLE BEND TERMINATIONS**

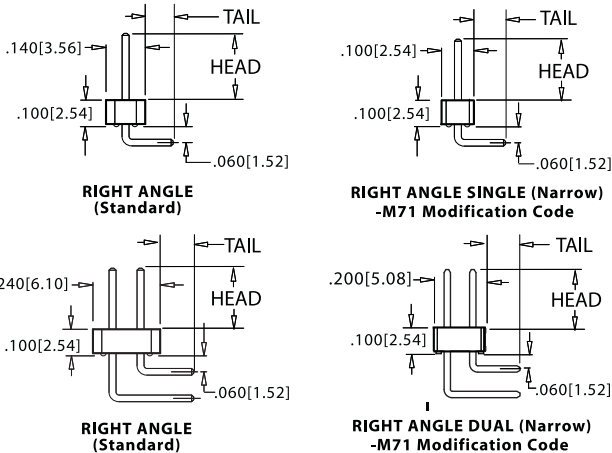

P/N CODE	HEAD DIMENSION	TAIL DIMENSION	-M71 TAIL DIMENSION
BA	.230[5.84]	.100[2.54]	.120[3.05]
BB	.230[5.84]	.200[5.08]	.220[5.59]
BC	.230[5.84]	.300[7.62]	.320[8.13]
BD	.230[5.84]	.400[10.16]	.420[10.67]
BE	.230[5.84]	.500[12.17]	.520[13.21]
BF**	.230[5.84]	.600[15.24]	.620[15.75]
BG**	.230[5.84]	.700[17.78]	.720[18.29]
BH*	.230[5.84]	.800[20.32]	.820[20.83]
BI*	.230[5.84]	.900[22.86]	.920[23.37]
BJ*	.230[5.84]	1.000[25.40]	1.020[25.91]
GA	.318[8.08]	.100[2.54]	.120[3.05]
GB	.318[8.08]	.200[5.08]	.220[5.59]
GC**	.318[8.08]	.300[7.62]	.320[8.13]
GD**	.318[8.08]	.400[10.16]	.420[10.67]
GE*	.318[8.08]	.600[15.24]	.620[15.75]
GF*	.318[8.08]	.800[20.32]	.820[20.83]
DA**	.120[3.05]	.120[3.05]	.140[3.56]

\*Consult Factory for availability.

\*\*Consult factory for availability in Dual Readout

Sullins Headers



**.100" [2.54 mm] Contact Centers, Male Breakaway Header  
Dip Solder/Right Angle/SMT**

**PART NUMBER OPTIONS**

**SERIES** \_\_\_\_\_

P = PBT/Phosphor Bronze  
Operating Temperature: -65°C to + 125°C  
Processing Temperature: 260° for 10 sec. Max. wave only

G = PA9T/Phosphor Bronze (Required on SMT)  
Operating Temperature: -65°C to + 150°C  
Processing Temperature: 260° for 10 sec. Max.

**CONTACT FINISH - RoHS Compliant** \_\_\_\_\_

**All platings are Lead Free and have .000050" Nickel underplate**

<b>Contact Surface</b>	<b>Termination</b>
B = .000010" Gold	.000100" Pure Tin, Matte
C = .000030" Gold	.000100" Pure Tin, Matte
<b>Contact Surface</b>	<b>Overall Plating</b>
E = .000010" Pure Tin, Matte	.000100" Pure Tin, Matte

**CONTACT CENTERS** \_\_\_\_\_

C = .100" [2.54mm]

**NUMBER OF POSITIONS** \_\_\_\_\_

01 Thru 36 (eg. 36 Dual = 72 Contacts)

**P B C 36 D AA N - Mxxx**

**MODIFICATION CODE (Consult Factory)**  
OMIT FOR STANDARD  
-M30 = SMT ('G' Material Only), Vertical  
-M89 = SMT ('G' Material Only), Horizontal  
-M71 = Narrow Body (Right Angle Only)

**MOUNTING STYLE**  
N = No Mounting  
R = Retention Lead (Single Row Only)

**TERMINATION TYPE (Opposite Page)**

**Straight** = AA, AB, AC, AD, AE, AF, AG, AH, AI, AJ, AK, FA, FB, FC, FD, FE, FF, FG, FH, FI, FJ, ZA, ZB, ZC, ZD, ZE, ZF, ZG, ZH, ZI, ZJ, ZK, ZL, ZM, ZN, ZO, ZP, ZQ, ZR

**Right Angle** = BA, BB, BC, BD, BE, BF, BG, BH, BI, BJ, GA, GB, GC, GD, GE, GF, DA

**Right Angle with -M71 Modification Code**  
= BA, BB, BC, BD, BE, BF, BG, BH, BI, BJ, GA, GB, GE, GF

**SMT with -M89 Modification Code**  
= BS, GS, ZC, ZU (*Single Row & 'G' Material Only*)

**SMT with -M30 Modification Code**  
= AB, FB, ZS, ZT (*'G' Material Only*)

**READOUT (Opposite Page)**  
S = Single  
D = Dual

**DIMENSIONS**

Dimensions in [ ] are in millimeters, all others are in inches.

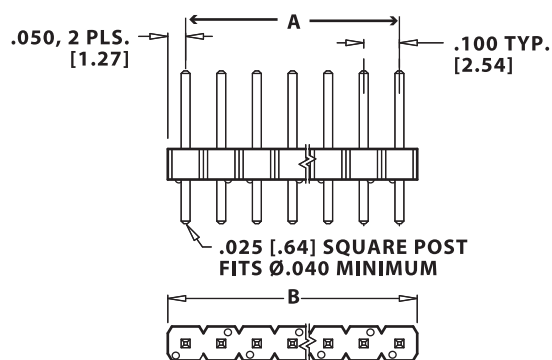

**SINGLE READOUT, STRAIGHT TAIL SHOWN**

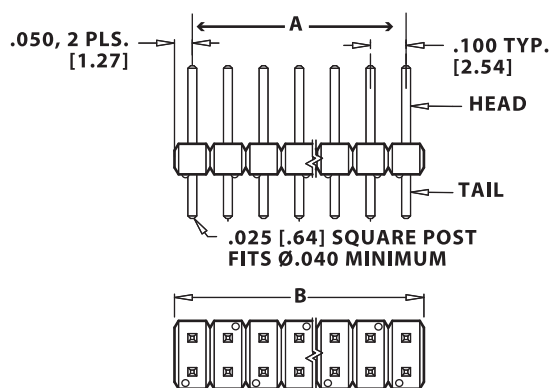

**DUAL READOUT, STRAIGHT TAIL SHOWN**

PART NUMBER	NUMBER OF CONTACTS SINGLE/DUAL	A		B	
		Inches	[MM]	Inches	[MM]
P_C01__N	01/02	0.000	0.00	0.100	2.54
P_C02__N	02/04	0.100	2.54	0.200	5.08
P_C03__N	03/06	0.200	5.08	0.300	7.62
P_C04__N	04/08	0.300	7.62	0.400	10.16
P_C05__N	05/10	0.400	10.16	0.500	12.70
P_C06__N	06/12	0.500	12.70	0.600	15.24
P_C07__N	07/14	0.600	15.24	0.700	17.78
P_C08__N	08/16	0.700	17.78	0.800	20.32
P_C09__N	09/18	0.800	20.32	0.900	22.86
P_C10__N	10/20	0.900	22.86	1.000	25.40
P_C11__N	11/22	1.000	25.40	1.100	27.94
P_C12__N	12/24	1.100	27.94	1.200	30.48
P_C13__N	13/26	1.200	30.48	1.300	33.02
P_C14__N	14/28	1.300	33.02	1.400	35.56
P_C15__N	15/30	1.400	35.56	1.500	38.10
P_C16__N	16/32	1.500	38.10	1.600	40.64
P_C17__N	17/34	1.600	40.64	1.700	43.18
P_C18__N	18/36	1.700	43.18	1.800	45.72
P_C19__N	19/38	1.800	45.72	1.900	48.26
P_C20__N	20/40	1.900	48.26	2.000	50.80
P_C21__N	21/42	2.000	50.80	2.100	53.34
P_C22__N	22/44	2.100	53.34	2.200	55.88
P_C23__N	23/46	2.200	55.88	2.300	58.42
P_C24__N	24/48	2.300	58.42	2.400	60.96
P_C25__N	25/50	2.400	60.96	2.500	63.50
P_C26__N	26/52	2.500	63.50	2.600	66.04
P_C27__N	27/54	2.600	66.04	2.700	68.58
P_C28__N	28/56	2.700	68.58	2.800	71.12
P_C29__N	29/58	2.800	71.12	2.900	73.66
P_C30__N	30/60	2.900	73.66	3.000	76.20
P_C31__N	31/62	3.000	76.20	3.100	78.74
P_C32__N	32/64	3.100	78.74	3.200	81.28
P_C33__N	33/66	3.200	81.28	3.300	83.82
P_C34__N	34/68	3.300	83.82	3.400	86.36
P_C35__N	35/70	3.400	86.36	3.500	88.90
P_C36__N	36/72	3.500	88.90	3.600	91.44



**.100" [2.54 mm] Contact Centers, Male Breakaway Header  
Dip Solder**

**SPECIFICATIONS**

- 3 amp current rating per contact
- UL Flammability Rating: 94V-0
- Insulator: PBT, Nylon 6T, LCP
- Contact Material: Brass

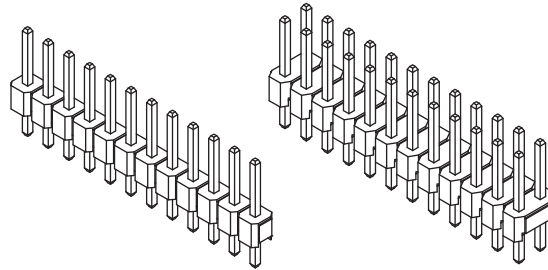

**TERMINATION TYPES STRAIGHT TERMINATIONS**

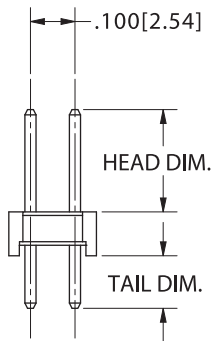
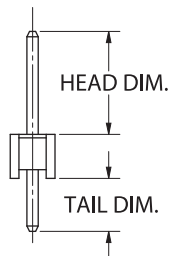

P/N CODE	HEAD DIMENSION	TAIL DIMENSION
AA	.230[5.84]	.120[3.05]
AB	.230[5.84]	.230[5.84]
AC	.230[5.84]	.320[8.13]
AD	.230[5.84]	.420[10.67]
AE	.230[5.84]	.520[13.21]
AF	.230[5.84]	.620[15.75]
AG	.230[5.84]	.720[18.29]
AH	.230[5.84]	.820[20.83]
AI	.230[5.84]	.900[22.86]
AJ	.230[5.84]	1.000[25.40]
AK	.230[5.84]	.035[0.89]
FA	.318[8.08]	.120[3.05]
FB	.318[8.08]	.220[5.59]
FC	.318[8.08]	.320[8.13]
FD	.318[8.08]	.420[10.67]
FE	.318[8.08]	.520[13.21]
FF	.318[8.08]	.620[15.75]
FG	.318[8.08]	.710[18.03]
FH	.318[8.08]	.810[20.57]
FI	.318[8.08]	.910[23.11]
FJ	.318[8.08]	.050[1.27]
ZA	.120[3.05]	.120[3.05]
ZB	.120[3.05]	.095[2.41]
ZC	.120[3.05]	.260[6.60]
ZD	.120[3.05]	.610[15.49]
ZI	.520[13.21]	.110[2.79]
ZJ	.720[18.29]	.110[2.79]
ZO	.820[20.83]	.110[2.79]
ZQ	1.020[25.91]	.110[2.79]
ZR	1.220[30.99]	.110[2.79]

**DIMENSIONS**

Dimensions in [ ] are in millimeters, all others are in inches.

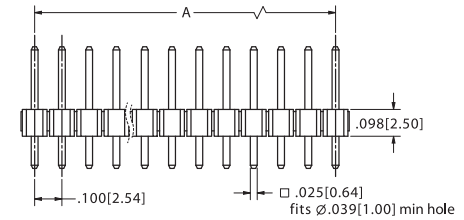
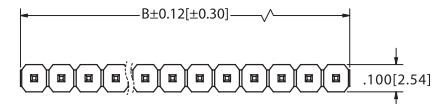

**SINGLE READOUT,  
STRAIGHT TAIL SHOWN**

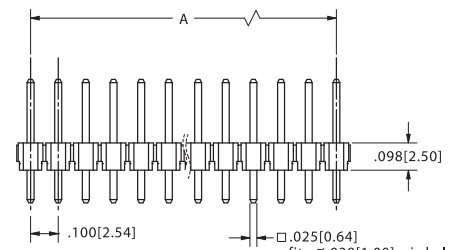
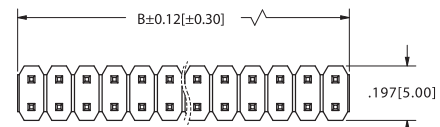

**DUAL READOUT,  
STRAIGHT TAIL SHOWN**

Sullins Headers



**.100" [2.54 mm] Contact Centers, Male Breakaway Header  
Dip Solder**

**PART NUMBER OPTIONS**

**INSULATOR/CONTACT MATERIAL** ——— **PR B C 002 S AA N - RC**

PR = PBT/BRASS  
Operating Temperature: -40°C to + 105°C  
Processing Temperature: Wave only.

NR = NYLON 6T/BRASS  
Operating Temperature: -40°C to + 105°C  
Processing Temperature: 230° for 60 sec. Max.  
(260° for 10 sec. Max.)

LR = LCP/BRASS  
Operating Temperature: -40°C to + 105°C  
Processing Temperature: 230° for 60 sec. Max.  
(260° for 10 sec. Max.)

**CONTACT FINISH - RoHS Compliant**

**All platings are Lead Free and have .000050" Nickel underplate**

**Contact Surface Termination**

B = .000010" Gold .000100" Pure Tin, Matte  
C = .000030" Gold .000100" Pure Tin, Matte  
E = Tin Overall  
P = Gold Flash Overall

**TERMINATION TYPE**  
AA, AB, AC, AD, AE, AF, AG, AH, AI, AJ, AK,  
FA, FB, FC, FD, FE, FF, FG, FH, FI, FJ,  
ZA, ZB, ZC, ZD, ZI, ZJ, ZO, ZQ, ZR

**READOUT**  
S = Single  
D = Dual

**NUMBER OF POSITIONS**  
Contacts Per Row, 002 Thru 040

**CONTACT CENTERS**  
.100" [2.54mm]

PART NUMBER	A		B		PART NUMBER	A		B	
	Inches	[MM]	Inches	[MM]		Inches	[MM]	Inches	[MM]
_R_C002S__N-RC	0.100	2.54	0.200	5.08	_R_C002D__N-RC	0.100	2.54	0.200	5.08
_R_C003S__N-RC	0.200	5.08	0.300	7.62	_R_C003D__N-RC	0.200	5.08	0.300	7.62
_R_C004S__N-RC	0.300	7.62	0.400	10.16	_R_C004D__N-RC	0.300	7.62	0.400	10.16
_R_C005S__N-RC	0.400	10.16	0.500	12.70	_R_C005D__N-RC	0.400	10.16	0.500	12.70
_R_C006S__N-RC	0.500	12.70	0.600	15.24	_R_C006D__N-RC	0.500	12.70	0.600	15.24
_R_C007S__N-RC	0.600	15.24	0.700	17.78	_R_C007D__N-RC	0.600	15.24	0.700	17.78
_R_C008S__N-RC	0.700	17.78	0.800	20.32	_R_C008D__N-RC	0.700	17.78	0.800	20.32
_R_C009S__N-RC	0.800	20.32	0.900	22.86	_R_C009D__N-RC	0.800	20.32	0.900	22.86
_R_C010S__N-RC	0.900	22.86	1.000	25.40	_R_C010D__N-RC	0.900	22.86	1.000	25.40
_R_C011S__N-RC	1.000	25.40	1.100	27.94	_R_C011D__N-RC	1.000	25.40	1.100	27.94
_R_C012S__N-RC	1.100	27.94	1.200	30.48	_R_C012D__N-RC	1.100	27.94	1.200	30.48
_R_C013S__N-RC	1.200	30.48	1.300	33.02	_R_C013D__N-RC	1.200	30.48	1.300	33.02
_R_C014S__N-RC	1.300	33.02	1.400	35.56	_R_C014D__N-RC	1.300	33.02	1.400	35.56
_R_C015S__N-RC	1.400	35.56	1.500	38.10	_R_C015D__N-RC	1.400	35.56	1.500	38.10
_R_C016S__N-RC	1.500	38.10	1.600	40.64	_R_C016D__N-RC	1.500	38.10	1.600	40.64
_R_C017S__N-RC	1.600	40.64	1.700	43.18	_R_C017D__N-RC	1.600	40.64	1.700	43.18
_R_C018S__N-RC	1.700	43.18	1.800	45.72	_R_C018D__N-RC	1.700	43.18	1.800	45.72
_R_C019S__N-RC	1.800	45.72	1.900	48.26	_R_C019D__N-RC	1.800	45.72	1.900	48.26
_R_C020S__N-RC	1.900	48.26	2.000	50.80	_R_C020D__N-RC	1.900	48.26	2.000	50.80
_R_C021S__N-RC	2.000	50.80	2.100	53.34	_R_C021D__N-RC	2.000	50.80	2.100	53.34
_R_C022S__N-RC	2.100	53.34	2.200	55.88	_R_C022D__N-RC	2.100	53.34	2.200	55.88
_R_C023S__N-RC	2.200	55.88	2.300	58.42	_R_C023D__N-RC	2.200	55.88	2.300	58.42
_R_C024S__N-RC	2.300	58.42	2.400	60.96	_R_C024D__N-RC	2.300	58.42	2.400	60.96
_R_C025S__N-RC	2.400	60.96	2.500	63.50	_R_C025D__N-RC	2.400	60.96	2.500	63.50
_R_C026S__N-RC	2.500	63.50	2.600	66.04	_R_C026D__N-RC	2.500	63.50	2.600	66.04
_R_C027S__N-RC	2.600	66.04	2.700	68.58	_R_C027D__N-RC	2.600	66.04	2.700	68.58
_R_C028S__N-RC	2.700	68.58	2.800	71.12	_R_C028D__N-RC	2.700	68.58	2.800	71.12
_R_C029S__N-RC	2.800	71.12	2.900	73.66	_R_C029D__N-RC	2.800	71.12	2.900	73.66
_R_C030S__N-RC	2.900	73.66	3.000	76.20	_R_C030D__N-RC	2.900	73.66	3.000	76.20
_R_C031S__N-RC	3.000	76.20	3.100	78.74	_R_C031D__N-RC	3.000	76.20	3.100	78.74
_R_C032S__N-RC	3.100	78.74	3.200	81.28	_R_C032D__N-RC	3.100	78.74	3.200	81.28
_R_C033S__N-RC	3.200	81.28	3.300	83.82	_R_C033D__N-RC	3.200	81.28	3.300	83.82
_R_C034S__N-RC	3.300	83.82	3.400	86.36	_R_C034D__N-RC	3.300	83.82	3.400	86.36
_R_C035S__N-RC	3.400	86.36	3.500	88.90	_R_C035D__N-RC	3.400	86.36	3.500	88.90
_R_C036S__N-RC	3.500	88.90	3.600	91.44	_R_C036D__N-RC	3.500	88.90	3.600	91.44
_R_C037S__N-RC	3.600	91.44	3.700	93.98	_R_C037D__N-RC	3.600	91.44	3.700	93.98
_R_C038S__N-RC	3.700	93.98	3.800	96.52	_R_C038D__N-RC	3.700	93.98	3.800	96.52
_R_C039S__N-RC	3.800	96.52	3.900	99.06	_R_C039D__N-RC	3.800	96.52	3.900	99.06
_R_C040S__N-RC	3.900	99.06	4.000	101.60	_R_C040D__N-RC	3.900	99.06	4.000	101.60



**.100" [2.54 mm] Contact Centers, Male Breakaway Header  
Right Angle/SMT**

**SPECIFICATIONS**

- 3 amp current rating per contact
- UL Flammability Rating: 94V-0
- Insulator: PBT, Nylon 6T, LCP
- Contact Material: Brass

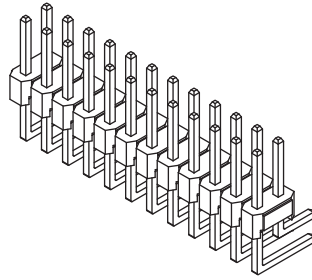

**RIGHT ANGLE BEND TERMINATIONS**

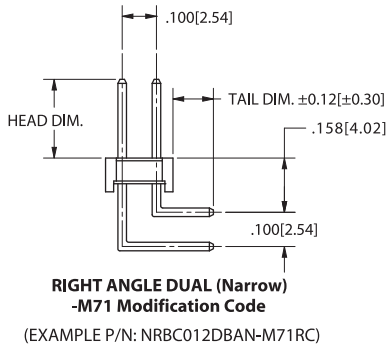
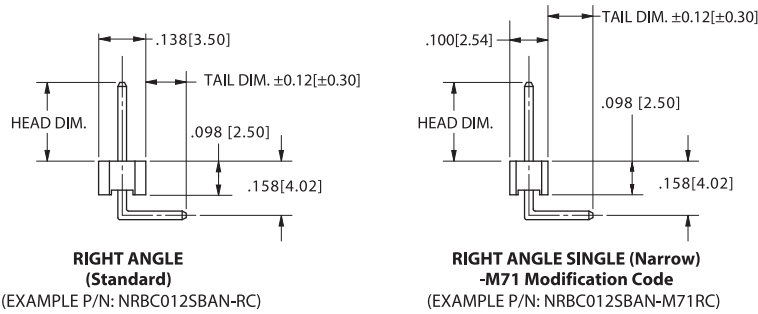

P/N CODE	HEAD DIMENSION	TAIL DIMENSION	-M71 TAIL DIMENSION
BA	.230[5.84]	.100[2.54]	.120[3.05]
BB	.230[5.84]	.200[5.08]	.220[5.59]
BC	.230[5.84]	.300[7.62]	.320[8.13]
BD	.230[5.84]	.400[10.16]	.420[10.67]
BE	.230[5.84]	.500[12.70]	.520[13.21]
BF*	.230[5.84]	.600[15.24]	.620[15.75]
BG*	.230[5.84]	.700[17.78]	.720[18.29]
BH	.230[5.84]	.800[20.32]	.820[20.83]
BI	.230[5.84]	.900[22.86]	.920[23.37]
BJ	.230[5.84]	1.000[25.40]	1.020[25.91]
GA	.318[8.08]	.100[2.54]	.120[3.05]
GB	.318[8.08]	.200[5.08]	.220[5.59]
GC*	.318[8.08]	.300[7.62]	.320[8.13]
GD*	.318[8.08]	.400[10.16]	.420[10.67]
GE	.318[8.08]	.600[15.24]	.620[15.75]
GF	.318[8.08]	.800[20.32]	.820[20.83]
DA*	.120[3.05]	.120[3.05]	.140[3.56]

\* CONSULT FACTORY FOR AVAILABILITY IN DUAL READOUT

**SMT TERMINATIONS**

**Single Row with -M89 Modification Code**

(EXAMPLE P/N: NRBC012SBSN-M89RC)

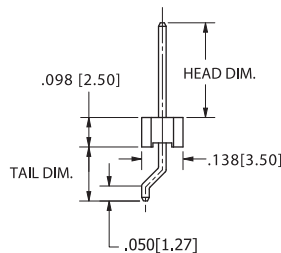

P/N CODE	HEAD DIMENSION	TAIL DIMENSION
BS	.230[5.84]	.180[4.57]
GS	.318[8.08]	.180[4.57]
ZC	.120[3.05]	.180[4.57]
ZU	.420[10.67]	.180[4.57]

**SMT TERMINATIONS**

**Single or Dual Row with -M30 Modification Code**

(EXAMPLE P/N: NRBC012SABC-M30RC)

(EXAMPLE P/N: NRBC012DABN-M30RC)

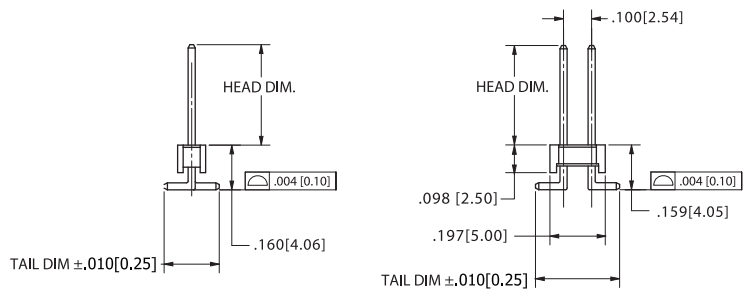

P/N CODE	HEAD DIMENSION	SINGLE ROW TAIL DIMENSION	DUAL ROW TAIL DIMENSION
AB	.230[5.84]	.320[8.13]	.420[10.67]
FB	.318[8.08]	.300[7.62]	.400[10.16]
ZS	.120[3.05]	.200[5.08]	.300[7.62]
ZT	.420[10.67]	.200[5.08]	.300[7.62]

Sullins Headers



**.100" [2.54 mm] Contact Centers, Male Breakaway Header  
Right Angle/SMT**

**PART NUMBER OPTIONS**

**INSULATOR/CONTACT MATERIAL**

PR = PBT/BRASS  
Operating Temperature: -40°C to + 105°C  
Processing Temperature: Wave only.

NR = NYLON 6T/BRASS  
Operating Temperature: -40°C to + 105°C  
Processing Temperature: 230° for 60 sec. Max.  
(260° for 10 sec. Max.)

LR = LCP/BRASS  
Operating Temperature: -40°C to + 105°C  
Processing Temperature: 230° for 60 sec. Max.  
(260° for 10 sec. Max.)

**CONTACT FINISH - RoHS Compliant**  
All platings are Lead Free and have .000050" Nickel underplate

**Contact Surface**  
B = .000010" Gold  
C = .000030" Gold  
E = Tin Overall  
P = Gold Flash Overall

**Termination**  
.000100" Pure Tin, Matte  
.000100" Pure Tin, Matte

**MODIFICATION CODE** (Consult Factory)  
OMIT FOR STANDARD ('NR' Material Only)  
-M30 = SMT ('NR' & 'LR' Material Only), Vertical  
-M89 = SMT ('NR' Material Only), Horizontal  
-M71 = Right Angle ('PR', 'NR', 'LR' Material), Narrow Body

**MOUNTING STYLE/ TERMINATION TYPES**  
N = No Mounting  
C= SMT, SINGLE ROW (STANDARD)  
D= SMT, SINGLE ROW (OPPOSITE BEND)

**TERMINATION TYPE**  
**Right Angle** = BA, BB, BC, BD, BE, BH, BI, BJ, GA, GB, GE, GF  
(single row or dual row)  
= BF, BG, GC, GD, DA (single row only)

**SMT with -M89 Modification Code**  
= BS, GS, ZC, ZU (Single Row Only)

**SMT with -M30 Modification Code**  
= AB, FB, ZS, ZT

**READOUT**  
S = Single  
D = Dual

**NUMBER OF POSITIONS**  
Contact Per Row, 002 Thru 040

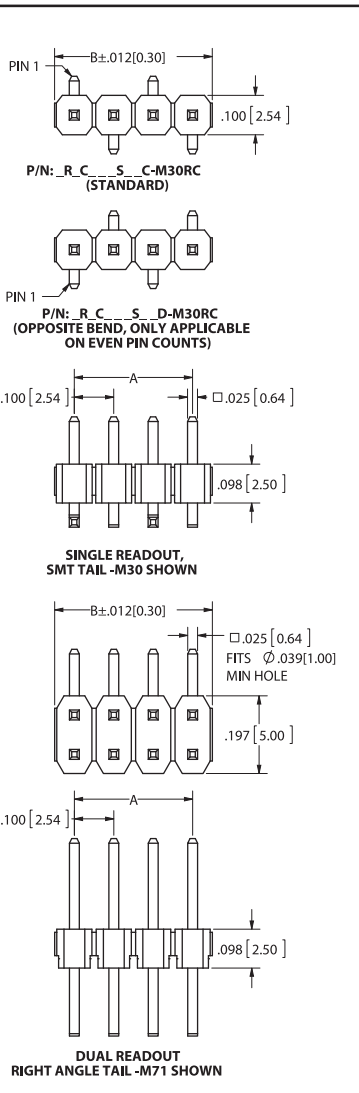

PART NUMBER	A		B	
	Inches	[MM]	Inches	[MM]
_R_C002_____RC	0.100	2.54	0.200	5.08
_R_C003_____RC	0.200	5.08	0.300	7.62
_R_C004_____RC	0.300	7.62	0.400	10.16
_R_C005_____RC	0.400	10.16	0.500	12.70
_R_C006_____RC	0.500	12.70	0.600	15.24
_R_C007_____RC	0.600	15.24	0.700	17.78
_R_C008_____RC	0.700	17.78	0.800	20.32
_R_C009_____RC	0.800	20.32	0.900	22.86
_R_C010_____RC	0.900	22.86	1.000	25.40
_R_C011_____RC	1.000	25.40	1.100	27.94
_R_C012_____RC	1.100	27.94	1.200	30.48
_R_C013_____RC	1.200	30.48	1.300	33.02
_R_C014_____RC	1.300	33.02	1.400	35.56
_R_C015_____RC	1.400	35.56	1.500	38.10
_R_C016_____RC	1.500	38.10	1.600	40.64
_R_C017_____RC	1.600	40.64	1.700	43.18
_R_C018_____RC	1.700	43.18	1.800	45.72
_R_C019_____RC	1.800	45.72	1.900	48.26
_R_C020_____RC	1.900	48.26	2.000	50.80
_R_C021_____RC	2.000	50.80	2.100	53.34
_R_C022_____RC	2.100	53.34	2.200	55.88
_R_C023_____RC	2.200	55.88	2.300	58.42
_R_C024_____RC	2.300	58.42	2.400	60.96
_R_C025_____RC	2.400	60.96	2.500	63.50
_R_C026_____RC	2.500	63.50	2.600	66.04
_R_C027_____RC	2.600	66.04	2.700	68.58
_R_C028_____RC	2.700	68.58	2.800	71.12
_R_C029_____RC	2.800	71.12	2.900	73.66
_R_C030_____RC	2.900	73.66	3.000	76.20
_R_C031_____RC	3.000	76.20	3.100	78.74
_R_C032_____RC	3.100	78.74	3.200	81.28
_R_C033_____RC	3.200	81.28	3.300	83.82
_R_C034_____RC	3.300	83.82	3.400	86.36
_R_C035_____RC	3.400	86.36	3.500	88.90
_R_C036_____RC	3.500	88.90	3.600	91.44
_R_C037_____RC	3.600	91.44	3.700	93.98
_R_C038_____RC	3.700	93.98	3.800	96.52
_R_C039_____RC	3.800	96.52	3.900	99.06
_R_C040_____RC	3.900	99.06	4.000	101.60

Sullins Headers



**.100" [2.54 mm] Contact Centers, Female Header  
Straight/Right Angle/SMT**

**SPECIFICATIONS**

- 3 amp current rating per contact
- UL Flammability Rating : 94V-O
- Insulator : Nylon 6-T/Polyester
- Contact Material : Phosphor Bronze

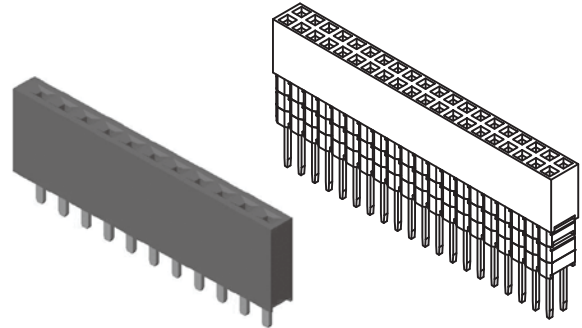

**TERMINATION TYPE**

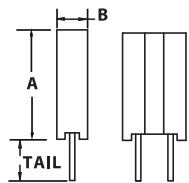

**STRAIGHT**

P/N CODE	ROWS	TERM	A	B	TAIL
LFB	1	STRAIGHT	.334[8.50]	.100[2.54]	.126[3.20]
	2	STRAIGHT	.334[8.50]	.200[5.08]	.126[3.20]

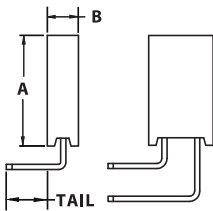

**RIGHT ANGLE**

P/N CODE	ROWS	TERM	A	B	TAIL
LGB	1	RIGHT ANGLE	.334[8.50]	0.100[2.54]	.124[3.15]
LJB	2	RIGHT ANGLE	.334[8.50]	0.200[5.08]	.124[3.15]

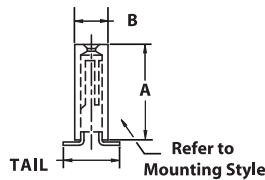

**SMT**

P/N CODE	ROWS	TERM	ENTRY	A	B	TAIL
KFX	1	SMT	TOP ENTRY	.279[7.10]	.098[2.50]	.169[4.30]
KFM	2	SMT	TOP ENTRY	.279[7.10]	.197[5.00]	.270[6.85]

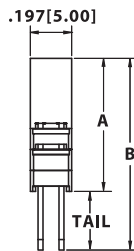

**2 ROW STRAIGHT WITH ELEVATED SPACER**

P/N CODE	ROWS	MODIFICATION	# OF SPACERS	A	B	TAIL
LFH	2	M44	1	.435[11.04]	.725[18.42]	.291[7.38]
	2	M45	2	.535[13.58]	.725[18.42]	.191[4.84]
	2	M46	3	.635[16.12]	.725[18.42]	.091[2.30]
	2	M50	1	.435[11.04]	.525[13.34]	.091[2.30]
	2	M51	1	.435[11.04]	.915[23.24]	.480[12.20]
	2	M52	2	.535[13.58]	.915[23.23]	.380[9.65]
	2	M53	3	.635[16.12]	.914[23.22]	.280[7.10]
	2	M54	4	.735[18.66]	.916[23.26]	.181[4.60]

**MOUNTING STYLE**



**No Mounting Standard (N)**

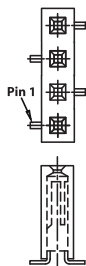

**One Row SMT, Pin 1 Left (C)**

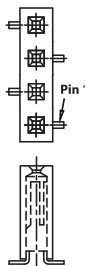

**One Row SMT, Pin 1 Right (D)**

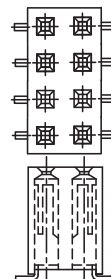

**Two Row SMT, Without Guide Post (S)**

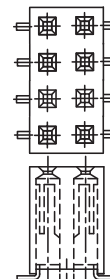

**Two Row SMT, With Guide Post (P)**

Sullins Headers



**.100" [2.54 mm] Contact Centers, Female Header  
Straight/Right Angle/SMT**

**PART NUMBER OPTIONS**

**PP P C 36 1 LFB N - Mxx RC**

**PLASTIC HOUSING**  
 PP = Polyester/Phosphor Bronze (Thru Hole Only)  
 NP = Nylon 6-T/Phosphor Bronze (not available in LFH Termination)

**CONTACT FINISH - RoHS Compliant**  
 P = Gold Flash Overall  
 T = 100% Pure Tin Overall

**CONTACT CENTERS**  
 C = .100" [2.54mm]

**NUMBER OF POSITIONS**  
 02 Thru 40  
 (e.g. 36 position has 72 contacts)

**RoHS Compliant**

**MODIFICATION (omit for Standard)**  
 Required for LFH Termination  
 see Termination Type on Opposite Page

**MOUNTING STYLE**  
 N = No Mounting  
 C = SMT, One Row, pin 1 Left  
 D = SMT, One Row, pin 1 Right  
 P = SMT, 2 Row with guide pins  
 S = SMT, 2 Row without guide pins

**TERMINATION TYPE**  
 LFB = Straight  
 LGB = 1 Row Right Angle  
 LJB = 2 Row Right Angle  
 KFX = 1 Row SMT (NP SERIES ONLY)  
 KFM = 2 Row SMT (NP SERIES ONLY)  
 LFH = 2 Row Straight with Elevated Spacer (Requires Modification see Opposite Page)

**NUMBER OF ROWS (Opposite Page)**  
 1 = 1 Row  
 2 = 2 Row

**PCB LAYOUT**

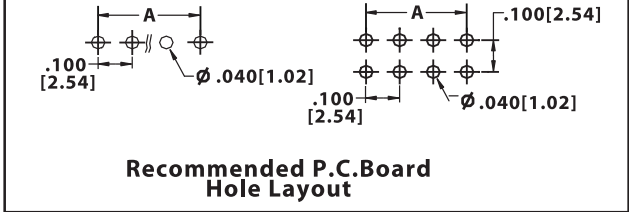

**DIMENSIONS**

Dimensions in [ ] are in millimeters, all others are in inches.

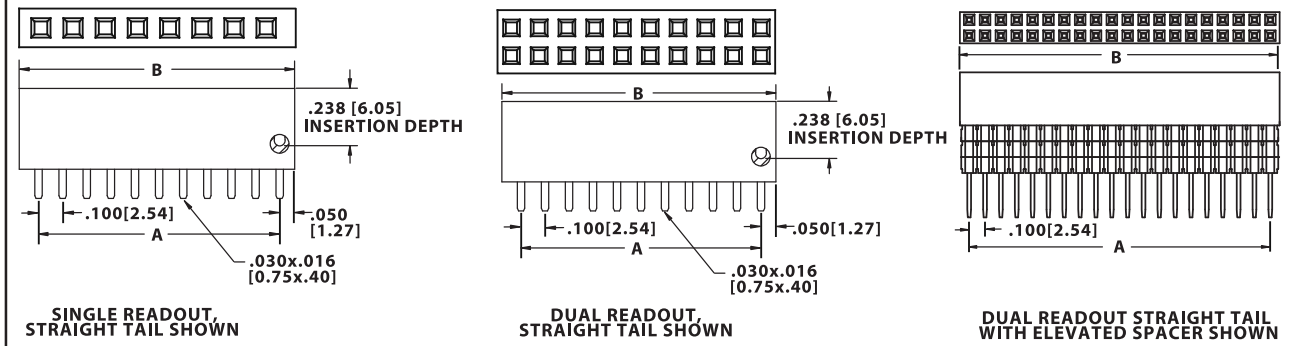

Number of Positions	Number of Contacts		Dimension A		Dimension B	
	1 Row	2 Row	Inches	[mm]	Inches	[mm]
01	1	2				
02	2	4	.100	2.54	.220	5.58
03	3	6	.200	5.08	.320	8.12
04	4	8	.300	7.62	.420	10.66
05	5	10	.400	10.16	.520	13.20
06	6	12	.500	12.70	.620	15.74
07	7	14	.600	15.24	.720	18.28
08	8	16	.700	17.78	.820	20.82
09	9	18	.800	20.32	.920	23.36
10	10	20	.900	22.86	1.020	25.90
11	11	22	1.000	25.40	1.120	28.44
12	12	24	1.100	27.94	1.220	30.98
13	13	26	1.200	30.48	1.320	33.52
14	14	28	1.300	33.02	1.420	36.06
15	15	30	1.400	35.56	1.520	38.60
16	16	32	1.500	38.10	1.620	41.14
17	17	34	1.600	40.64	1.720	43.68
18	18	36	1.700	43.18	1.820	46.22
19	19	38	1.800	45.72	1.920	48.76
20	20	40	1.900	48.26	2.020	51.30

Number of Positions	Number of Contacts		Dimension A		Dimension B	
	1 Row	2 Row	Inches	[mm]	Inches	[mm]
21	21	42	2.000	50.80	2.120	53.84
22	22	44	2.100	53.34	2.220	56.38
23	23	46	2.200	55.88	2.320	58.92
24	24	48	2.300	58.42	2.420	61.46
25	25	50	2.400	60.96	2.520	64.00
26	26	52	2.500	63.50	2.620	66.54
27	27	54	2.600	66.04	2.720	69.08
28	28	56	2.700	68.58	2.820	71.62
29	29	58	2.800	71.12	2.920	74.16
30	30	60	2.900	73.66	3.020	76.70
31	31	62	3.000	76.20	3.120	79.24
32	32	64	3.100	78.74	3.220	81.78
33	33	66	3.200	81.28	3.320	84.32
34	34	68	3.300	83.82	3.420	86.86
35	35	70	3.400	86.36	3.520	89.40
36	36	72	3.500	88.90	3.620	91.94
37	37	74	3.600	91.44	3.720	94.48
38	38	76	3.700	93.98	3.820	97.02
39	39	78	3.800	96.52	3.920	99.56
40	40	80	3.900	99.06	4.020	102.10



**.100" [2.54mm] Contact Centers, Top/Bottom Entry SMT Female Headers**

**SPECIFICATIONS**

- Insulator Material: Nylon 6T, UL 94V-0
- Contact Resistance: 20m OHMs Max.
- Current Rating: 3 AMPS per contact
- Dielectric With Standing: 1000 V AC.
- Insulation Resistance: 5000 Mega OHMS Min.
- Operating Temperature: - 40° C to + 105° C
- Processing Temperature: 230° C for 60 seconds Max.

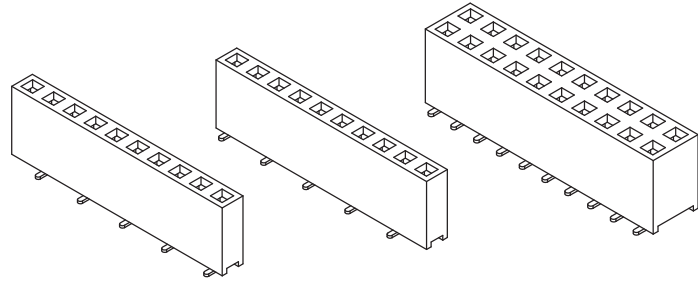

**RECOMMENDED PCB LAYOUT**

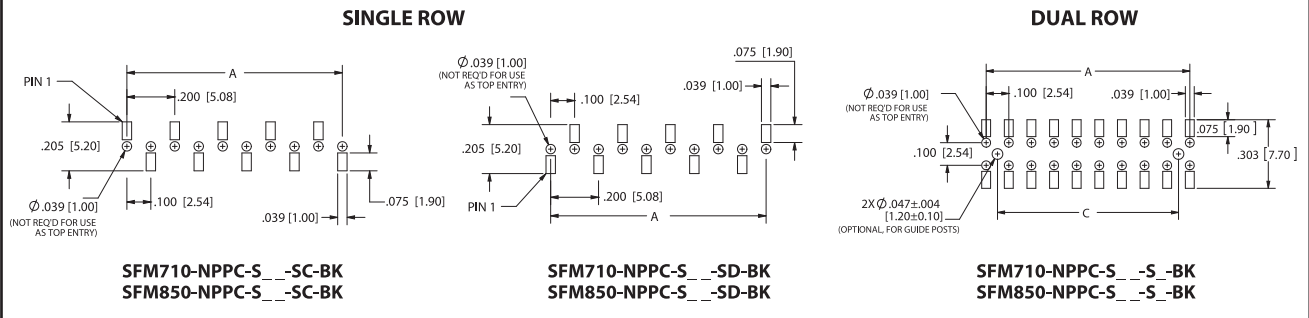

**DIMENSIONS**

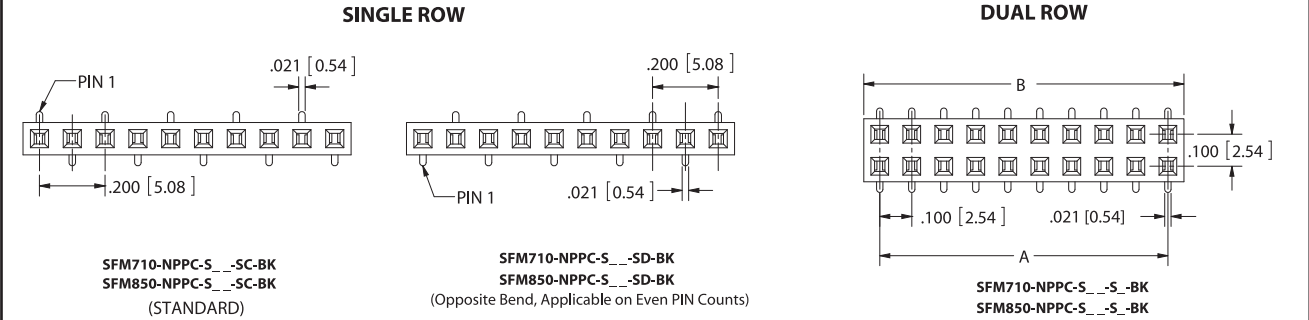

FOR SFM850 SINGLE ROW / DUAL ROW SERIES

No. of Contacts Single/Dual	A		B (Single Row)		B (Daul Row)		C	
	inch	mm	inch	mm	inch	mm	inch	mm
02/04*	0.100	2.54	0.224	5.68	0.216	5.48	N/A	N/A
03/06	0.200	5.08	0.324	8.22	0.316	8.02	0.100	2.54
04/08	0.300	7.62	0.424	10.76	0.416	10.56	0.200	5.08
05/10	0.400	10.16	0.524	13.30	0.516	13.10	0.300	7.62
06/12	0.500	12.70	0.624	15.84	0.616	15.64	0.400	10.16
07/14	0.600	15.24	0.724	18.38	0.716	18.18	0.500	12.70
08/16	0.700	17.78	0.824	20.92	0.816	20.72	0.600	15.24
09/18	0.800	20.32	0.924	23.46	0.916	23.26	0.700	17.78
10/20	0.900	22.86	1.024	26.00	1.016	25.80	0.800	20.32
11/22	1.000	25.40	1.124	28.54	1.116	28.34	0.900	22.86
12/24	1.100	27.94	1.224	31.08	1.216	30.88	1.000	25.40
13/26	1.200	30.48	1.324	33.62	1.316	33.42	1.100	27.94
14/28	1.300	33.02	1.424	36.16	1.416	35.96	1.200	30.48
15/30	1.400	35.56	1.524	38.70	1.516	38.50	1.300	33.02
16/32	1.500	38.10	1.624	41.24	1.616	41.04	1.400	35.56
17/34	1.600	40.64	1.724	43.78	1.716	43.58	1.500	38.10
18/36	1.700	43.18	1.824	46.32	1.816	46.12	1.600	40.64
19/38	1.800	45.72	1.924	48.86	1.916	48.66	1.700	43.18
20/40	1.900	48.26	2.024	51.40	2.016	51.20	1.800	45.72
21/42	2.000	50.80	2.124	53.94	2.116	53.74	1.900	48.26

No. of Contacts Single/Dual	A		B (Single Row)		B (Daul Row)		C	
	inch	mm	inch	mm	inch	mm	inch	mm
22/44	2.100	53.34	2.224	56.48	2.216	56.28	2.000	50.80
23/46	2.200	55.88	2.324	59.02	2.316	58.82	2.100	53.34
24/48	2.300	58.42	2.424	61.56	2.416	61.36	2.200	55.88
25/50	2.400	60.96	2.524	64.10	2.516	63.90	2.300	58.42
26/52	2.500	63.50	2.624	66.64	2.616	66.44	2.400	60.96
27/54	2.600	66.04	2.724	69.18	2.716	68.98	2.500	63.50
28/56	2.700	68.58	2.824	71.72	2.816	71.52	2.600	66.04
29/58	2.800	71.12	2.924	74.26	2.916	74.06	2.700	68.58
30/60	2.900	73.66	3.024	76.80	3.016	76.60	2.800	71.12
31/62	3.000	76.20	3.124	79.34	3.116	79.14	2.900	73.66
32/64	3.100	78.74	3.224	81.88	3.216	81.68	3.000	76.20
33/66	3.200	81.28	3.324	84.42	3.316	84.22	3.100	78.74
34/68	3.300	83.82	3.424	86.96	3.416	86.76	3.200	81.28
35/70	3.400	86.36	3.524	89.50	3.516	89.30	3.300	83.82
36/72	3.500	88.90	3.624	92.04	3.616	91.84	3.400	86.36
37/74	3.600	91.44	3.724	94.58	3.716	94.38	3.500	88.90
38/76	3.700	93.98	3.824	97.12	3.816	96.92	3.600	91.44
39/78	3.800	96.52	3.924	99.66	3.916	99.46	3.700	93.98
40/80	3.900	99.06	4.024	102.20	4.016	102.00	3.800	96.52

\* NOT AVAILABLE WITH GUIDE POSTS

Sullins Headers



**.100" [2.54mm] Contact Centers, Top/Bottom Entry SMT Female Counters**

**PART NUMBER OPTIONS**

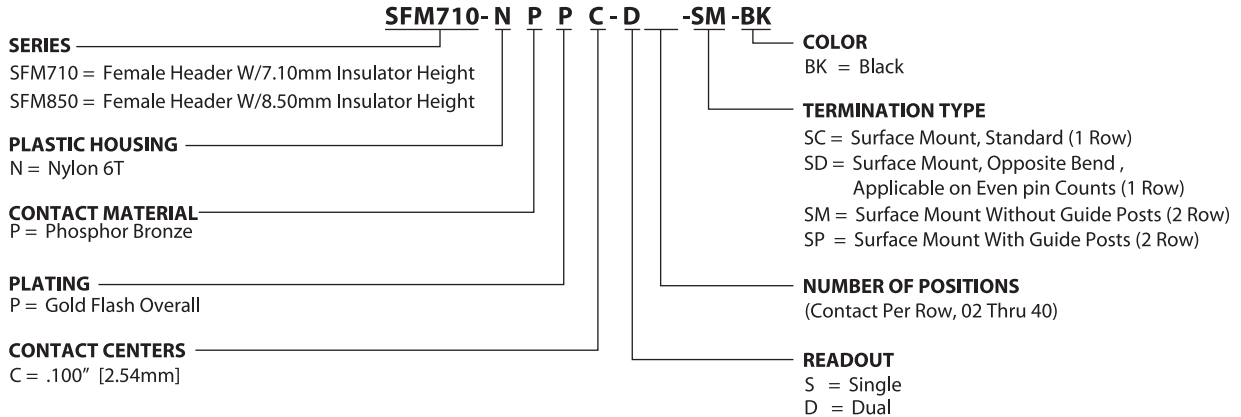

**DIMENSIONS**

**SFM710 Series Single Row**

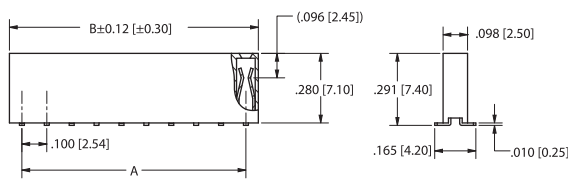

**SFM850 Series Single Row**

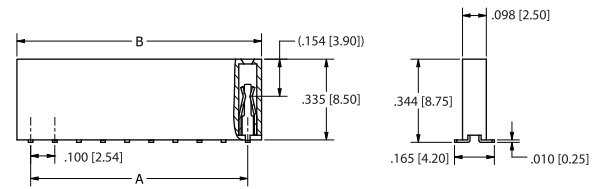

**SFM710 Series Dual Row**

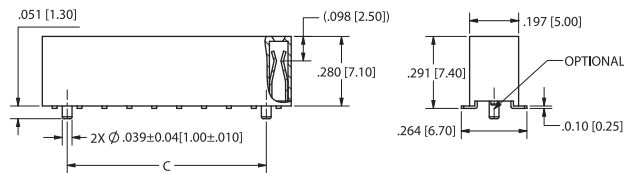

**SFM850 Series Dual Row**

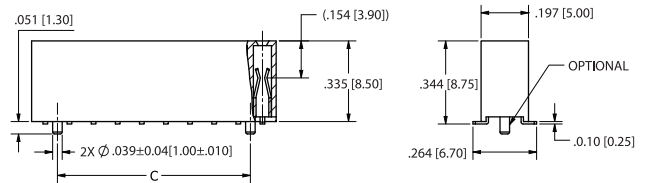

FOR SFM710 SINGLE ROW / DUAL ROW SERIES

No. of Contacts Single/Dual	A		B (Single Row)		B (Dual Row)		C	
	inch	mm	inch	mm	inch	mm	inch	mm
02/04*	0.100	2.54	0.200	5.08	0.200	5.08	N/A	N/A
03/06	0.200	5.08	0.300	7.62	0.300	7.62	0.100	2.54
04/08	0.300	7.62	0.416	10.56	0.400	10.16	0.200	5.08
05/10	0.400	10.16	0.516	13.10	0.500	12.70	0.300	7.62
06/12	0.500	12.70	0.616	15.64	0.600	15.24	0.400	10.16
07/14	0.600	15.24	0.716	18.18	0.700	17.78	0.500	12.70
08/16	0.700	17.78	0.816	20.72	0.800	20.32	0.600	15.24
09/18	0.800	20.32	0.916	23.26	0.900	22.86	0.700	17.78
10/20	0.900	22.86	1.016	25.80	1.000	25.40	0.800	20.32
11/22	1.000	25.40	1.116	28.34	1.100	27.94	0.900	22.86
12/24	1.100	27.94	1.216	30.88	1.200	30.48	1.000	25.40
13/26	1.200	30.48	1.316	33.42	1.300	33.02	1.100	27.94
14/28	1.300	33.02	1.416	35.96	1.400	35.56	1.200	30.48
15/30	1.400	35.56	1.516	38.50	1.500	38.10	1.300	33.02
16/32	1.500	38.10	1.616	41.04	1.600	40.64	1.400	35.56
17/34	1.600	40.64	1.716	43.58	1.700	43.18	1.500	38.10
18/36	1.700	43.18	1.816	46.12	1.800	45.72	1.600	40.64
19/38	1.800	45.72	1.916	48.66	1.900	48.26	1.700	43.18
20/40	1.900	48.26	2.016	51.20	2.000	50.80	1.800	45.72
21/42	2.000	50.80	2.116	53.74	2.100	53.34	1.900	48.26

\* NOT AVAILABLE WITH GUIDE POST

No. of Contacts Single/Dual	A		B (Single Row)		B (Dual Row)		C	
	inch	mm	inch	mm	inch	mm	inch	mm
22/44	2.100	53.34	2.216	56.28	2.200	55.88	2.000	50.80
23/46	2.200	55.88	2.316	58.82	2.300	58.42	2.100	53.34
24/48	2.300	58.42	2.416	61.36	2.400	60.96	2.200	55.88
25/50	2.400	60.96	2.516	63.90	2.500	63.50	2.300	58.42
26/52	2.500	63.50	2.616	66.44	2.600	66.04	2.400	60.96
27/54	2.600	66.04	2.716	68.98	2.700	68.58	2.500	63.50
28/56	2.700	68.58	2.816	71.52	2.800	71.12	2.600	66.04
29/58	2.800	71.12	2.916	74.06	2.900	73.66	2.700	68.58
30/60	2.900	73.66	3.016	76.60	3.000	76.20	2.800	71.12
31/62	3.000	76.20	3.116	79.14	3.100	78.74	2.900	73.66
32/64	3.100	78.74	3.216	81.68	3.200	81.28	3.000	76.20
33/66	3.200	81.28	3.316	84.22	3.300	83.82	3.100	78.74
34/68	3.300	83.82	3.416	86.76	3.400	86.36	3.200	81.28
35/70	3.400	86.36	3.516	89.30	3.500	88.90	3.300	83.82
36/72	3.500	88.90	3.616	91.84	3.600	91.44	3.400	86.36
37/74	3.600	91.44	3.716	94.38	3.700	93.98	3.500	88.90
38/76	3.700	93.98	3.816	96.92	3.800	96.52	3.600	91.44
39/78	3.800	96.52	3.916	99.46	3.900	99.06	3.700	93.98
40/80	3.900	99.06	4.016	102.00	4.000	101.60	3.800	96.52



### .100" [2.54mm] Contact Centers, Shrouded (Box) Headers

### Straight/Right Angle/SMT - SBH Series

Mates with SFH11 series (See page 107) and SFH210 series (see page 108)

## SPECIFICATIONS

- Centered Polarizing Notch
- Operating Temperature: - 40° C to + 85° C
- Processing Temperature: 230° C for 60 seconds Max. (260° C, 10 seconds)
- UL Flammability Rating: 94V-0
- Voltage Rating: 20m OHMs Max.
- Current Rating: 3 AMP per contact
- Voltage Drop: AC 500 V.
- Insulation Resistance: 1000 Mega OHMS

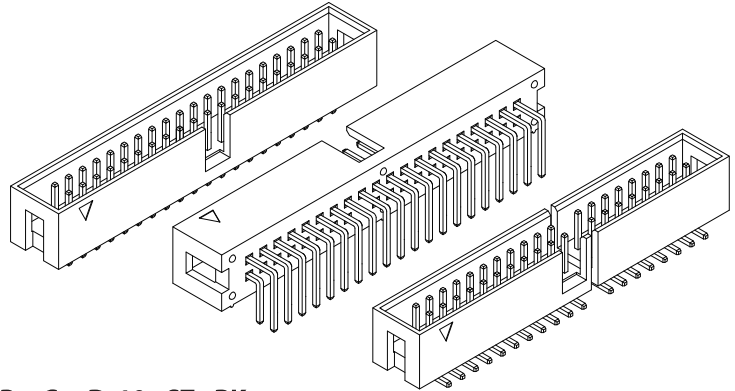

## PART NUMBER OPTIONS

**SBH11 - P B P C - D 10 - ST - BK**

### SERIES

SBH11 = Box Header with Centered Polarizing Notch

### HOUSING MATERIAL

P = PBT  
N = Nylon 6T

### CONTACT MATERIAL

B = Brass

### CONTACT FINISH - RoHS Compliant

P = Gold Flash Overall

### CONTACT CENTERS

C = .100" [2.54mm]

### COLOR

BK = Black  
Other Color Options Available  
(Consult Factory)

### TERMINATION TYPE

ST = Straight  
RA = Right Angle  
SM = Surface Mount, 'N' Material Only

### NUMBER OF CONTACT POSITIONS (Pins per Row)

03 thru 08, 10, 12, 13, 15, 17, 20, 22, 25, 30, 32

### NUMBER OF ROWS

D = Dual Row

## DIMENSIONS For complete drawings, go to [www.sullinscorp.com](http://www.sullinscorp.com) or e-mail [techsupport@sullinscorp.com](mailto:techsupport@sullinscorp.com)

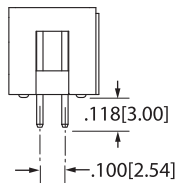

### STRAIGHT (ST)

Example P/N: SBH11-PBPC-D20-ST-BK

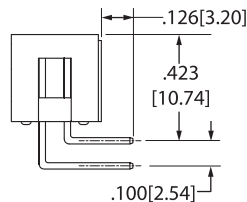

### RIGHT ANGLE (RA)

Example P/N: SBH11-PBPC-D20-RA-BK

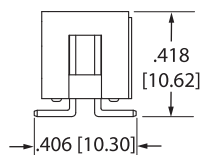

### SURFACE MOUNT (SM)

Example P/N: SBH11-NBPC-D20-SM-BK

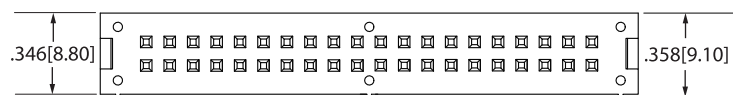
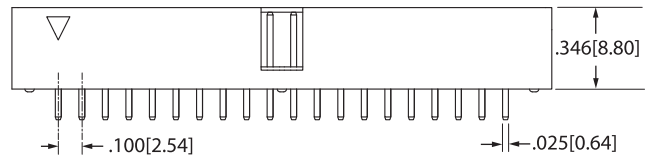
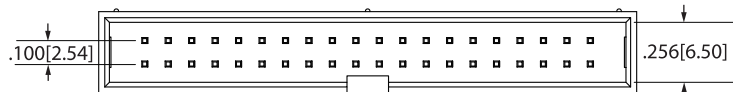

Sullins Headers



**.100" [2.54mm] Contact Centers, Female Headers  
Straight/Right Angle- SFH Series  
Mates with SBH11 series (See opposite page)**

**SPECIFICATIONS**

- **Centered Polarizing Key Optional**
- Operating Temperature: - 40° C to + 105° C
- Processing Temperature: 230° C for 60 seconds Max.  
(260° C, 10 seconds)
- UL Flammability Rating: 94V-0
- Voltage Rating: 20m OHMs Max.
- Current Rating: 3 AMP per contact
- Dielectric Withstanding: 500 VAC
- Insulation Resistance: 1000 Mega OHMS

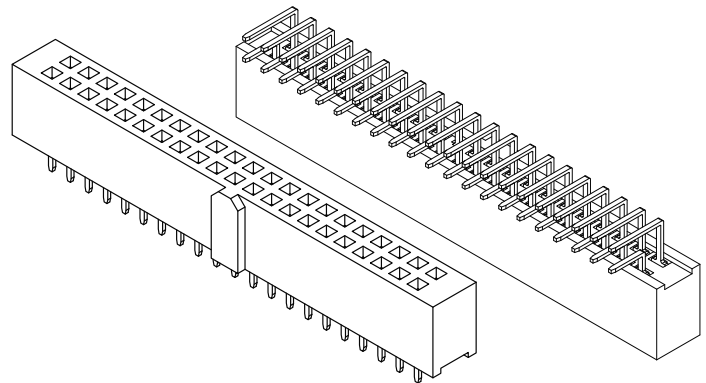

**PART NUMBER OPTIONS**

**SFH11 - P P P C - D 10 - ST - BK - M181**

**SERIES**

SFH11 = Female Header with Centered Polarizing Key

**HOUSING MATERIAL**

P = PBT

**CONTACT MATERIAL**

P = Phosphor Bronze  
B = Brass

**CONTACT FINISH - RoHS Compliant**

P = Gold Flash Overall  
E = .000100" Pure Tin, Matte, Overall

**CONTACT CENTERS**

C = .100" [2.54mm]

**MODIFICATION (Omit for Standard)**

M181 = Without Centered Polarizing Key

**COLOR**

BK = Black  
GY = Grey

**TERMINATION TYPE (Opposite Page)**

ST = Straight  
RA = Right Angle

**NUMBER OF CONTACT POSITIONS**

03 thru 08,10,12, 13, 15,17, 20, 25, 30, 32

**NUMBER OF ROWS**

D = Dual Row

**DIMENSIONS** For complete drawings, go to [www.sullinscorp.com](http://www.sullinscorp.com) or e-mail [techsupport@sullinscorp.com](mailto:techsupport@sullinscorp.com)

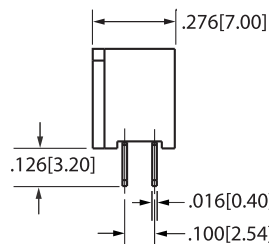

**STRAIGHT (ST)**

Example P/N: SFH11-PPPC-D20-ST-BK

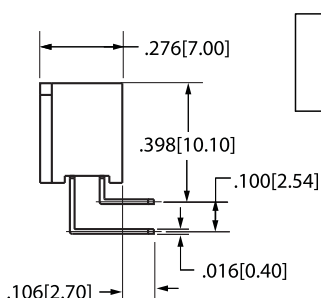

**RIGHT ANGLE (RA)**

Example P/N: SFH11-PPPC-D20-RA-BK

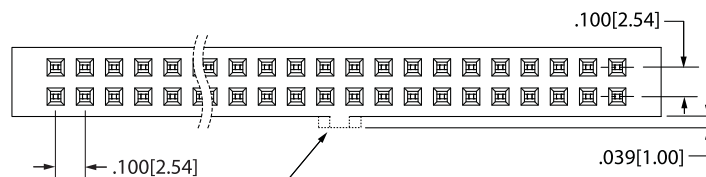

Centered Polarizing Key Optional,  
Requires -M181 Modification to Remove

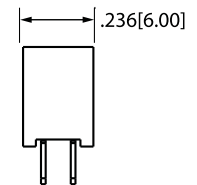

**-M181 Modification  
(No Centered  
Polarizing Key)**

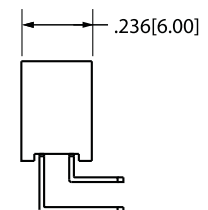

**-M181 Modification  
(No Centered  
Polarizing Key)**



# .100" [2.54 mm] Contact Centers, IDC Socket, Insulation Displacement- SFH Series With or Without Strain Relief Mates with SBH11 series (See page 106)

## SPECIFICATIONS

- **Centered Polarizing Key Optional**
- Operating Temperature: - 40° C to + 105° C
- UL Flammability Rating: 94V-0
- Current Rating: 1 AMP per contact
- Dielectric Withstanding: 500 VAC
- Insulation Resistance: 3,000 Mega OHMS
- For 1.27 mm Pitch AWG 26-28 Flat Ribbon Cable

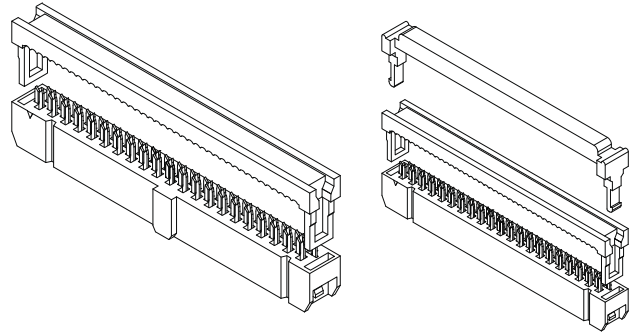

## PART NUMBER OPTIONS

**SFH210 - P P P C - D 10 - ID - BK - Mxxx**

**SERIES**  
SFH210 = IDC Socket, Without Strain Relief  
SFH213 = IDC Socket, With Strain Relief

**HOUSING MATERIAL**  
P = PBT

**CONTACT MATERIAL**  
P = Phosphor Bronze

**CONTACT FINISH - RoHS Compliant**  
P = Gold Flash Overall  
E = .000100" Pure Tin, Matte, Overall  
V = Gold Flash on Contact Surface, Nickel Underplate on Tails  
J = .000015" Gold on Contact Surface, Gold Flash on Tails  
K = .000015" Gold on Contact Surface, Nickel Underplate on Tails

**MODIFICATION (Omit for Standard)**  
M181 = Without Centered Polarizing Key  
M207 = With Polarizing Key, With Mylar in Tape & Reel (only for SFH210)  
M208 = Without Polarizing Key, With Mylar in Tape and Reel (only for SFH210)

**COLOR**  
BK = Black

**TERMINATION TYPE**  
ID = Insulation Displacement

**NUMBER OF CONTACT POSITIONS**  
03 thru 13, 15, 17, 20, 25, 30, 32  
\*M208 and M207 not available in 30 or 32

**NUMBER OF ROWS**  
D = Dual Row

**CONTACT CENTERS**  
C = .100" [2.54mm]

## DIMENSIONS For complete drawings, go to [www.sullinscorp.com](http://www.sullinscorp.com) or e-mail [techsupport@sullinscorp.com](mailto:techsupport@sullinscorp.com)

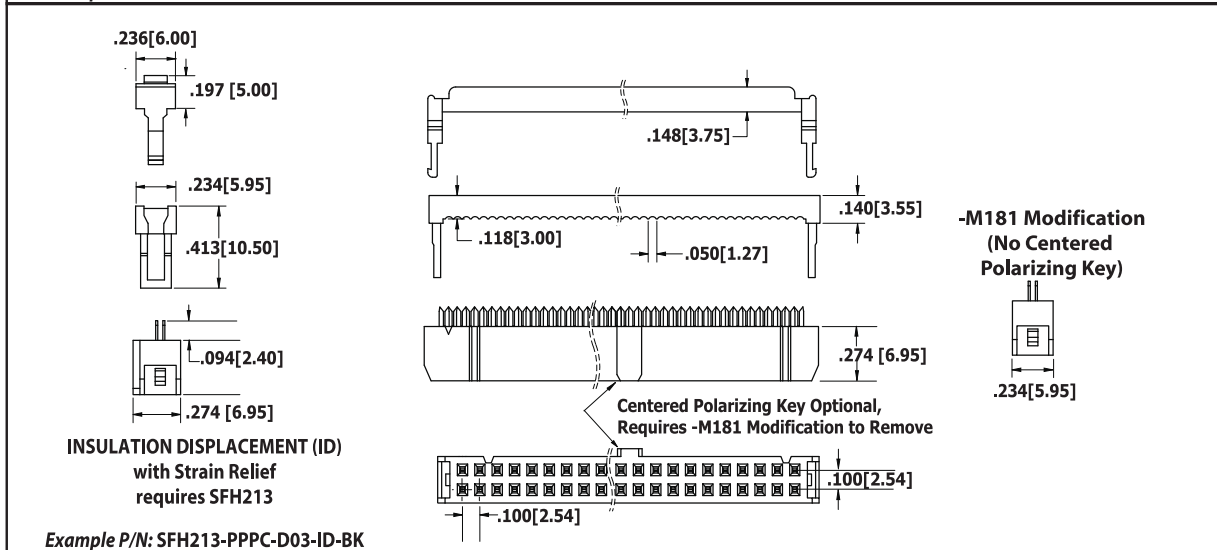
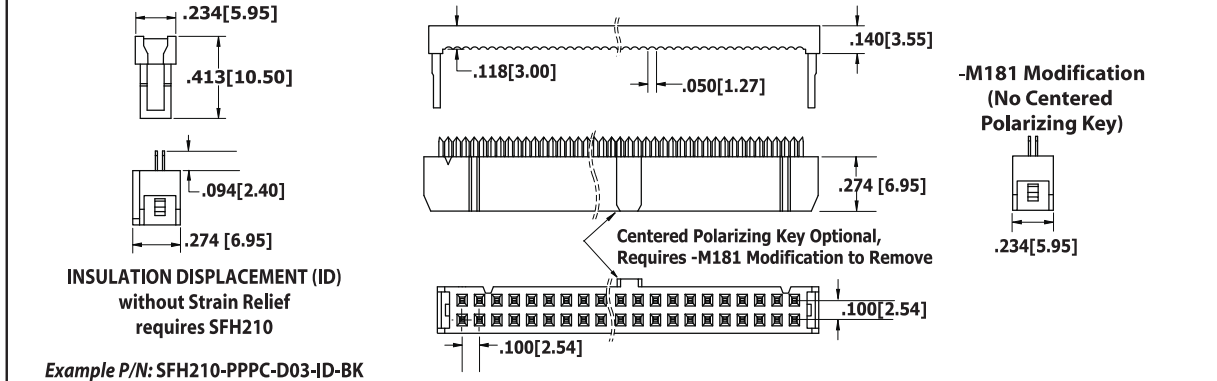

Sullins Headers



**.100" [2.54 mm] Contact Centers, IDC Dip Plug  
Straight - SIP Series**

**SPECIFICATIONS**

- Operating Temperature: - 40° C to + 105° C
- Current Rating: 1 AMP per contact
- Dielectric Withstanding: 1,000 VAC
- Insulation Resistance: 5,000 Mega OHMS
- For 1.27 mm Pitch AWG 26-28 Flat Ribbon Cable
- UL Flammability Rating: 94V-0

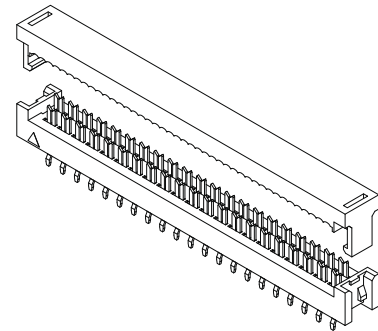

**PART NUMBER OPTIONS**

**SIP110 - P P P C - D 10 - ST - BK**

**SERIES** \_\_\_\_\_  
SIP110 = IDC Dip Plug

**HOUSING MATERIAL** \_\_\_\_\_  
P = PBT

**CONTACT MATERIAL** \_\_\_\_\_  
P = Phosphor Bronze

**CONTACT FINISH - RoHS Compliant** \_\_\_\_\_  
P = Gold Flash Overall  
E = .000100" Pure Tin, Matte, Overall  
V = Gold Flash on Contact Surface, Nickel Underplate on Tails  
J = .000015" Gold on Contact Surface, Gold Flash on Tails  
K = .000015" Gold on Contact Surface, Nickel Underplate on Tails

**COLOR**  
BK = Black

**TERMINATION TYPE**  
ST = Straight  
SK = Straight with Kink

**NUMBER OF CONTACT POSITIONS**  
03 thru 10, 12, 13, 14, 15, 17, 20, 25, 30, 32

**NUMBER OF ROWS**  
D = Dual Row

**CONTACT CENTERS**  
C = .100" [2.54mm]

**DIMENSIONS** For complete drawings, go to [www.sullinscorp.com](http://www.sullinscorp.com) or e-mail [techsupport@sullinscorp.com](mailto:techsupport@sullinscorp.com)

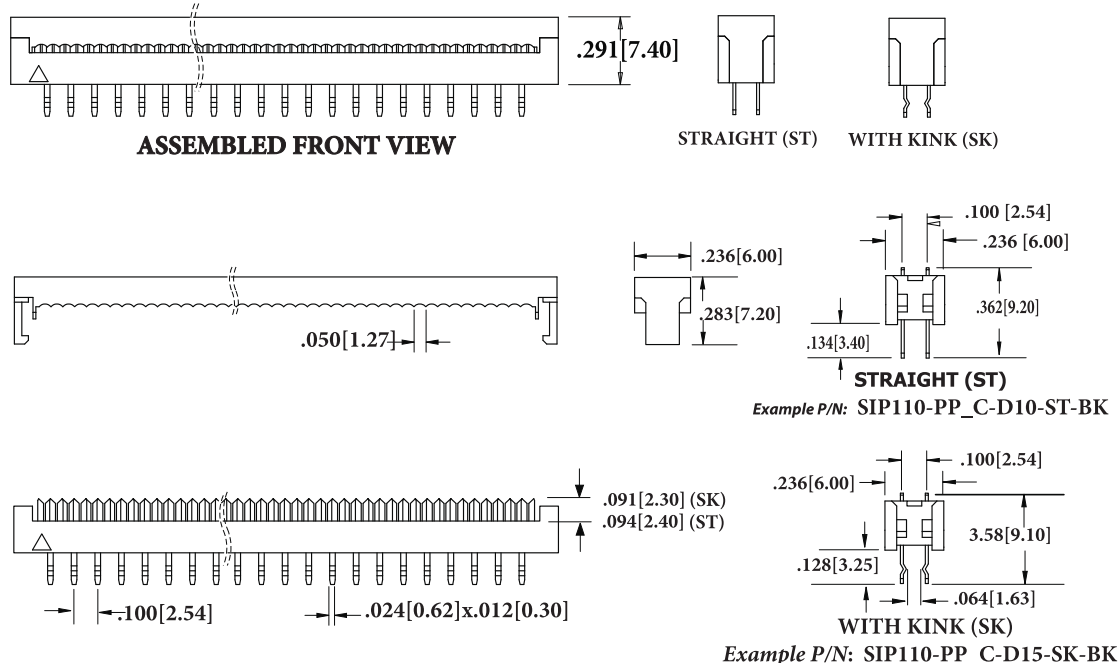

Sullins Headers



**.050" [1.27 mm] Contact Centers, Jumper  
Closed Top**

**SPECIFICATIONS**

- Insulator Material: Nylon 66
- Contact Material: Phosphor Bronze
- Plating: Overall Gold Flash
- 1 amp current rating per contact
- UL Flammability Rating: 94V-0/94V-2
- Dual Beam Contacts

**PART NUMBER OPTIONS**

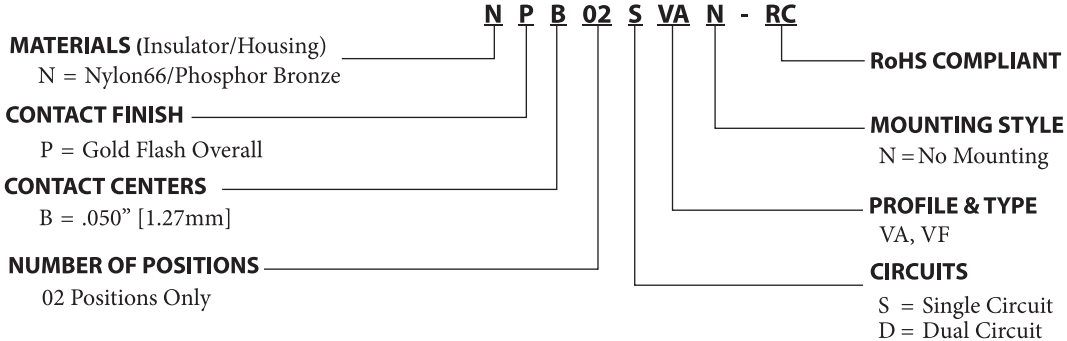

**DIMENSIONS** Dimensions in [ ] are in millimeters, all others are in inches.

**CLOSED TOP - DUAL CIRCUIT**

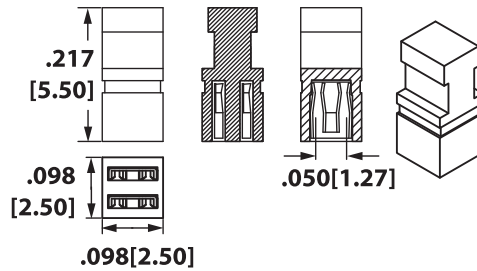

**CLOSED TOP - SINGLE CIRCUIT**

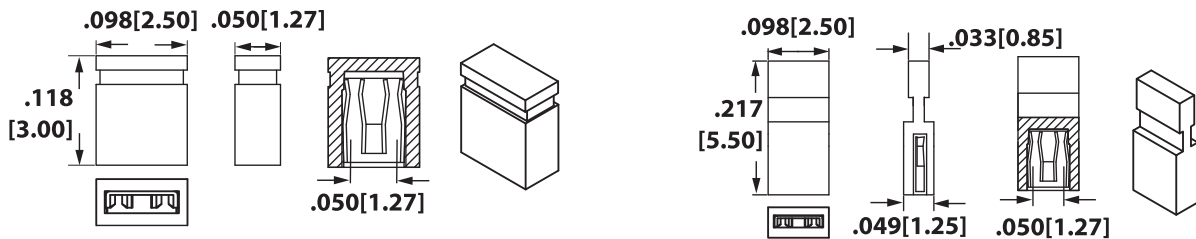

Sullins Jumpers



**SPECIFICATIONS**

- Insulator Material: Nylon 66 / PBT
- Contact Material: Phosphor Bronze
- Plating: Overall Gold Flash
- 1, 2 or 3 amp current rating per contact
- UL Flammability Rating: 94V-0/94V-2
- Dual Beam Contacts

**PART NUMBER OPTIONS**

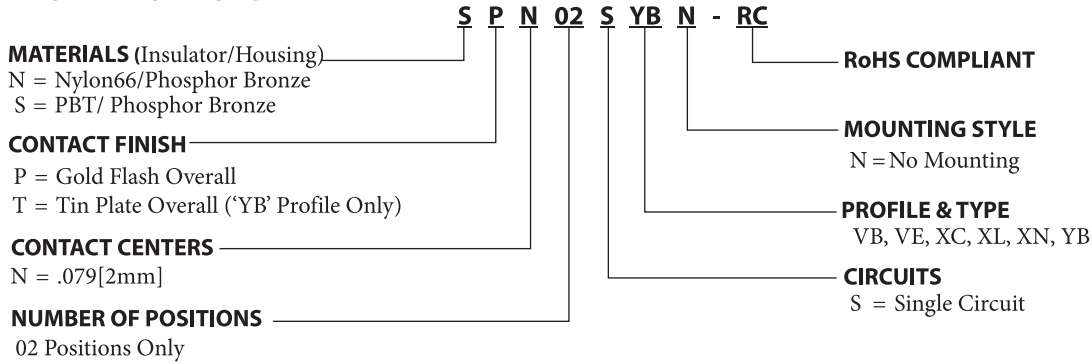

**DIMENSIONS**

Dimensions in [ ] are in millimeters, all others are in inches.

**OPEN TOP - SINGLE CIRCUIT**

**STANDARD**

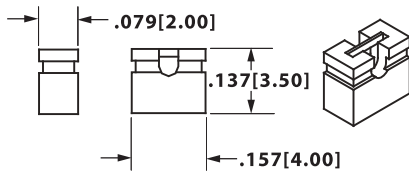

**SPN02SYBN-RC  
STN02SYBN-RC**

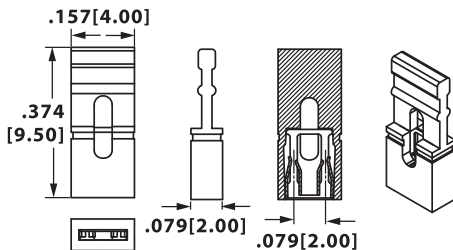

**NPN02SXLN-RC**

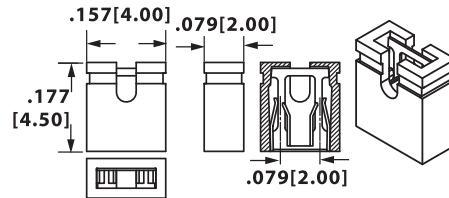

**SPN02SXCN-RC**

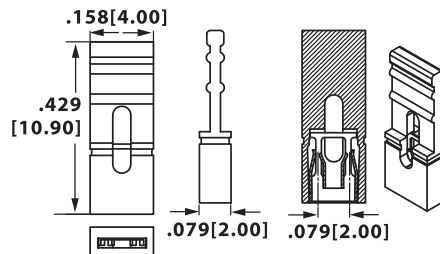

**NPN02SXNN-RC**

**CLOSED TOP - SINGLE CIRCUIT**

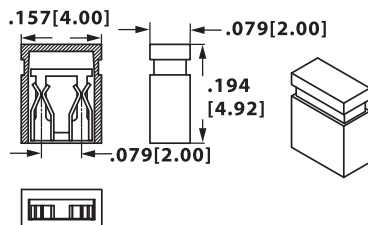

**SPN02SVEN-RC**

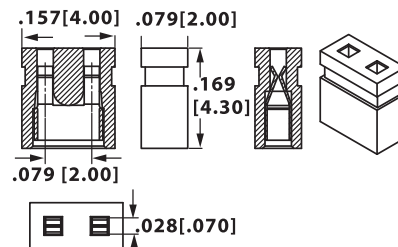

**SPN02SVBN-RC**

Sullins Jumpers



**.100" [2.54 mm] Contact Centers, Jumper  
Open / Closed Top**

**SPECIFICATIONS**

- Insulator Material: Nylon 66/ PBT
- Contact Material: Phosphor Bronze / Brass
- Plating: Overall Gold Flash
- 3 amp current rating per contact
- UL Flammability Rating: 94V-0/94V-2
- Dual Beam Contacts

**DIMENSIONS** Dimensions in [ ] are in millimeters, all others are in inches.

**OPEN TOP - SINGLE CIRCUIT**

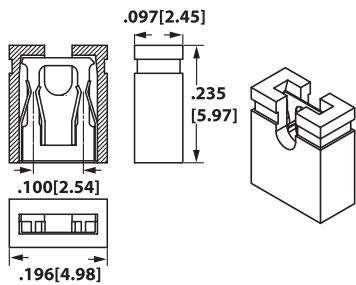

**QPC02SXGN-RC**

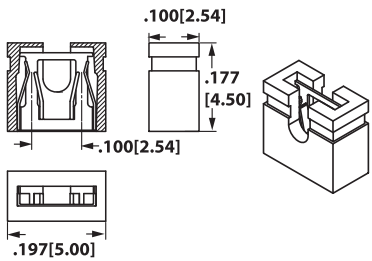

**SPC02SXCN-RC**

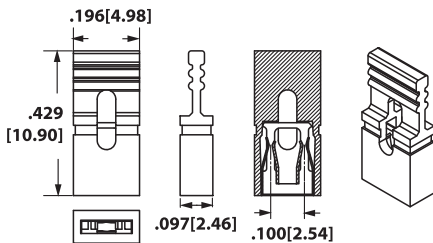

**NPC02SXNN-RC**

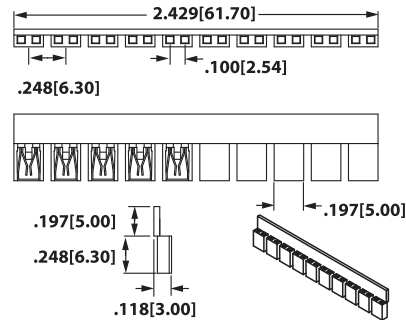

**QPC02SXHN-M290RC (Strip of 10)**

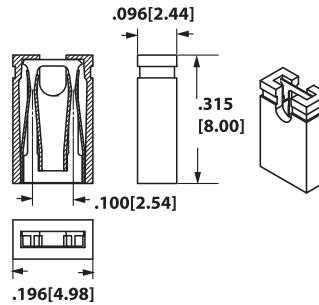

**SPC02SXIN-RC**

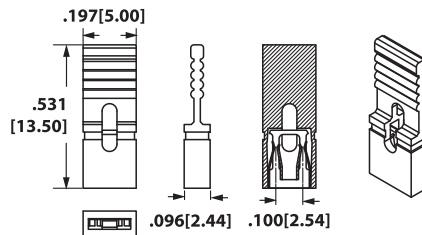

**NPC02SXON-RC**

**OPEN TOP - CHOICE OF CIRCUITS**

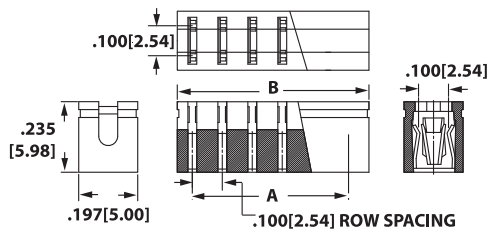

**QPC02\_XGN-RC**

PART NUMBER	CIRCUITS	A		B	
		INCH	MM	INCH	MM
QPC02DXGN-RC	2	0.100	2.54	0.200	5.08
QPC02TXGN-RC	3	0.200	5.08	0.300	7.62
QPC02QXGN-RC	4	0.300	7.62	0.400	10.16
QPC02UXGN-RC	5	0.400	10.16	0.500	12.70
QPC02EXGN-RC	6	0.500	12.70	0.600	15.24
QPC02PXGN-RC	7	0.600	15.24	0.700	17.78
QPC02CXGN-RC	8	0.700	17.78	0.800	20.32
QPC02NXGN-RC	9	0.800	20.32	0.900	22.86
QPC02AXGN-RC	10	0.900	22.86	1.000	25.40
QPC02RXGN-RC	13	1.200	30.48	1.300	33.02



**.100" [2.54 mm] Contact Centers, Jumper  
Open / Closed Top**

**PART NUMBER OPTIONS**

	<b>S</b>	<b>P</b>	<b>C</b>	<b>02</b>	<b>S</b>	<b>VD</b>	<b>N</b>	<b>- RC</b>	
<b>MATERIALS</b> (Insulator/Housing)	N = Nylon66/Phosphor Bronze	S = PBT/Phosphor Bronze	Q = PBT/Brass						<b>RoHS COMPLIANT</b> QPC02SGBN-M290RC, strip of 10 jumpers (See opposite page)
<b>CONTACT FINISH - RoHS Compliant</b>	P = Gold Flash Overall	S = .000010" Gold Overall ('YA' Profile only, see below)	T = Tin Overall ('YA' Profile only, see below)						<b>MOUNTING STYLE</b> N = No Mounting
<b>CONTACT CENTERS</b>	C = .100" [2.54]								<b>PROFILE &amp; TYPE</b> VD, VG, VJ, VK, XC, XG, XH, XI, XN, XO, YA
<b>NUMBER OF POSITIONS</b>	02 Positions Only								<b>CIRCUITS</b> S = 1 Circuit D = 2 Circuits T = 3 Circuits Q = 4 Circuits U = 5 Circuits E = 6 Circuits P = 7 Circuits C = 8 Circuits N = 9 Circuits A = 10 Circuits R = 13 Circuits

**DIMENSIONS** Dimensions in [ ] are in millimeters, all others are in inches.

**CLOSED TOP - SINGLE CIRCUIT**

**STANDARD**

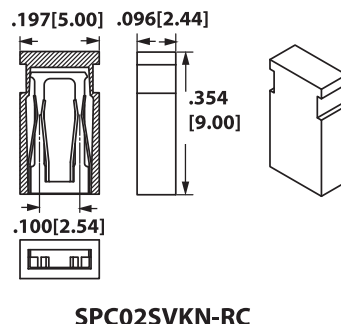
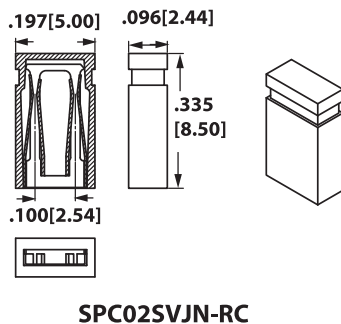
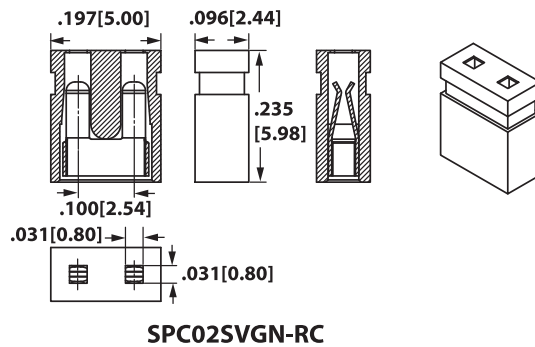
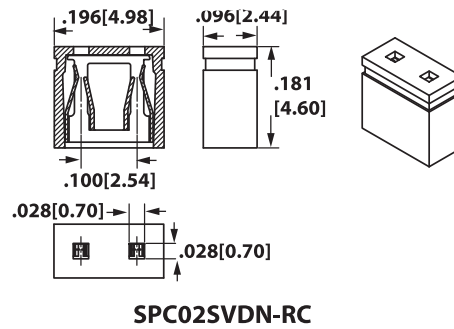
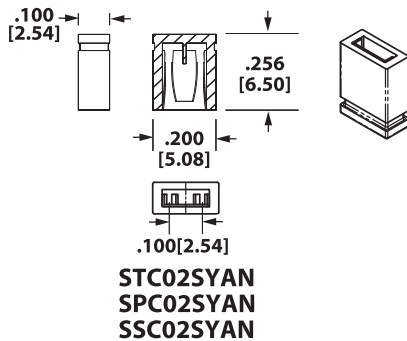

Sullins Jumpers



### SWT 201 Series Crimp Terminal

#### SPECIFICATIONS

- Material: Phosphor Bronze.
- Contact Resistance: 20m OHMs Max.
- Current Rating: 1 AMP per contact
- Plating: See Part Number Coding.
- Wire Range: AWG #24 - #28.
- Insulation O.D.:  $\varnothing 1.20\text{mm} \sim \varnothing 1.50\text{mm}$ .
- Quantity Per Reel = 10,000 Pieces.
- Used In SWH201 SERIES Housing.

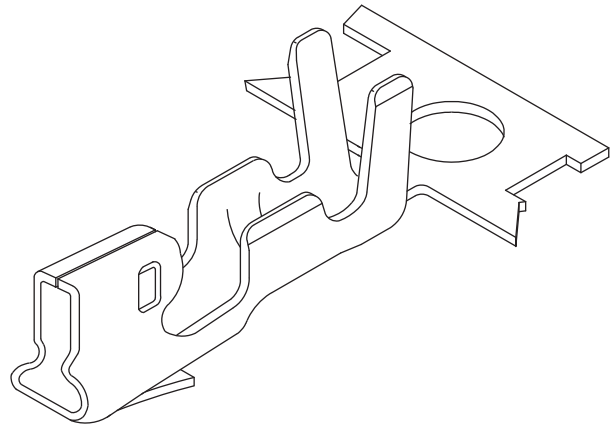

#### PART NUMBER CODING

SWT201-UP N-501-UU-UU

**Plating**

T= .000015" Min Nickel Underplate, .000040" Min Pure Tin, Bright Overall.  
 P= .000040" Min Nickel Underplate, Gold Flash Overall.

#### DIMENSIONS

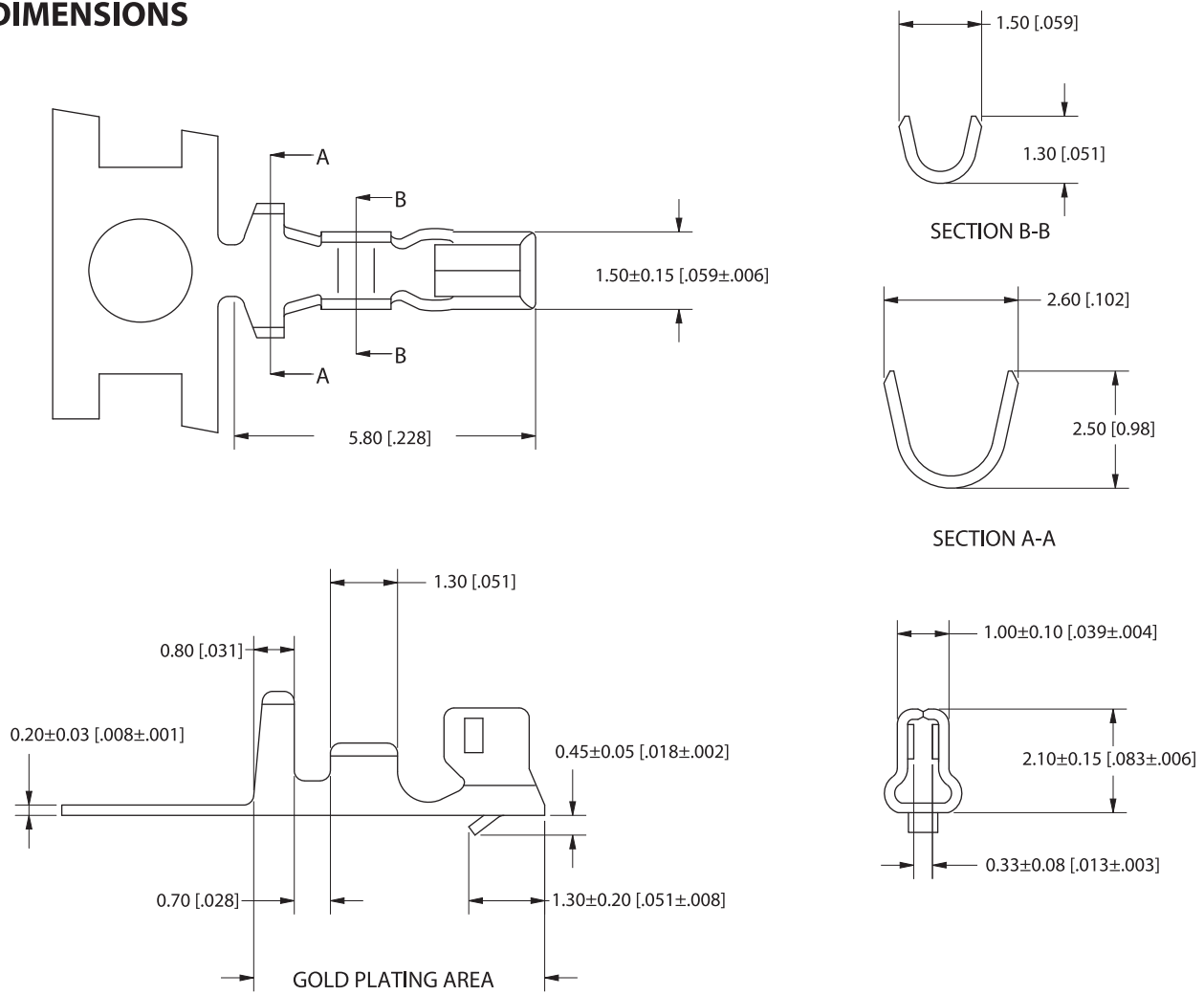

Sullins Wafers



**SWH201 Series Housing 2.0mm[.079"] Contact Centers**

**SPECIFICATIONS**

- Insulator Material: Nylon 66, UL 94V-0 Color: White.
- Dielectric WithStanding Voltage: 800 V AC.
- Insulation Resistance: 1000 Mega OHMS MIN.
- Operating Temperature: -25° C TO +85° C.
- Voltage Rating: 125V AC/DC.
- SUITABLE FOR SWT201 SERIES TERMINAL.
- MATES WITH SWR201 SERIES SINGLE ROW WAFER.

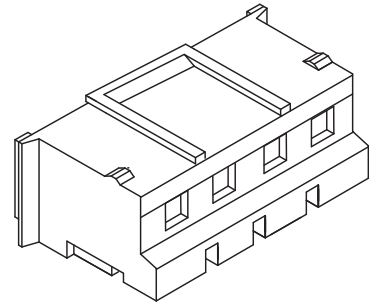

**DIMENSIONS**

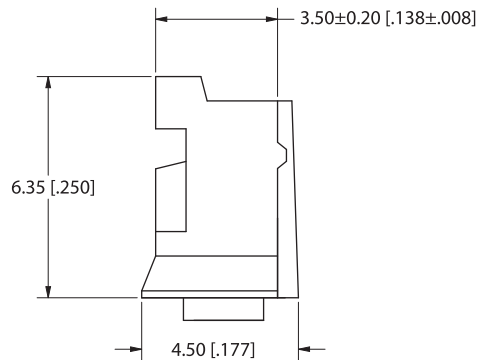
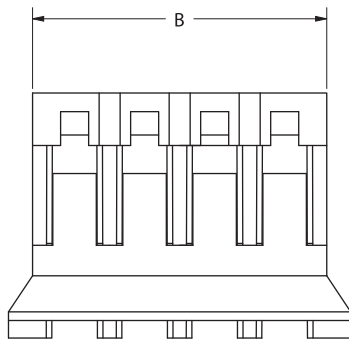
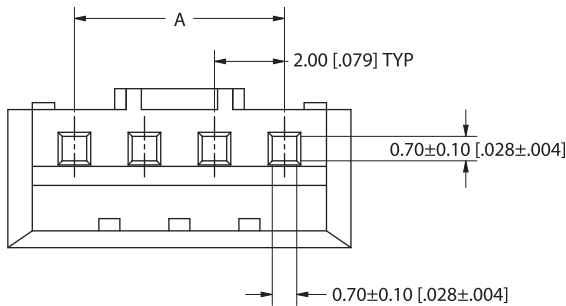

**PART NUMBER CODING**

**SWH201-NULN-S -UU-WH**

Number Of Positions  
(Contacts Per row)

Part Number	Positions/ Contacts	A		B	
		mm	inch	mm	inch
SWH201-NULN-S02-UU-WH	02/02	2.00	0.079	4.40	0.173
SWH201-NULN-S03-UU-WH	03/03	4.00	0.157	6.40	0.252
SWH201-NULN-S04-UU-WH	04/04	6.00	0.236	8.40	0.331
SWH201-NULN-S05-UU-WH	05/05	8.00	0.315	10.40	0.409
SWH201-NULN-S06-UU-WH	06/06	10.00	0.394	12.40	0.488
SWH201-NULN-S07-UU-WH	07/07	12.00	0.472	14.40	0.567
SWH201-NULN-S08-UU-WH	08/08	14.00	0.551	16.40	0.646
SWH201-NULN-S09-UU-WH	09/09	16.00	0.630	18.40	0.724
SWH201-NULN-S10-UU-WH	10/10	18.00	0.709	20.40	0.803
SWH201-NULN-S11-UU-WH	11/11	20.00	0.787	22.40	0.882
SWH201-NULN-S12-UU-WH	12/12	22.00	0.866	24.40	0.961
SWH201-NULN-S13-UU-WH	13/13	24.00	0.945	26.40	1.039
SWH201-NULN-S14-UU-WH	14/14	26.00	1.024	28.40	1.118
SWH201-NULN-S15-UU-WH	15/15	28.00	1.102	30.40	1.197
SWH201-NULN-S16-UU-WH	16/16	30.00	1.181	32.40	1.276



### SWR201 Series Single Row Wafer 2.0mm [.079"] Contact Centers, Straight/Right Angle

#### SPECIFICATIONS

- Insulator Material: Nylon 66, UL 94V-0 Color: White.
- Contact Material: Brass
- Contact Resistance: 20m OHMs Max.
- Contact Plating: .000020" Min. Nickel Underplate, Pure Tin, Bright Overall.
- Current Rating: 1 AMP per contact
- Dielectric WithStanding Voltage: 800 V AC.
- Insulation Resistance: 1000 Mega OHMS Min.
- Operating Temperature: -25° C TO +85° C.
- Voltage Rating: 125V AC/DC.
- MATES WITH SWH201 SERIES SINGLE ROW HOUSING.

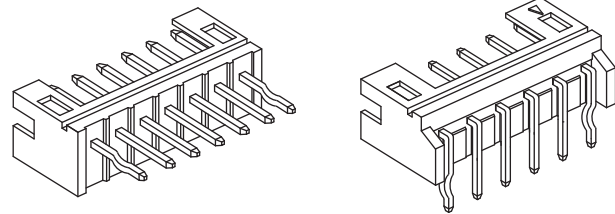

#### PART NUMBER CODING

**SWR201-NRTN-S - -WH**

Number Of Positions  
(Contacts Per row)

Termination Type

SA= End Pins Kink Right

RL= Right Angle With Kinked End Pins

#### RECOMMENDED PCB LAYOUT

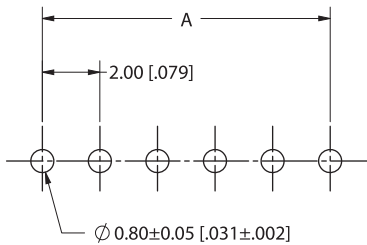

P.C. BOARD THICKNESS: 0.80 ~ 1.60mm [.031" ~ .063"]

Part Number	Positions/ Contacts	A		B	
		mm	inch	mm	inch
SWR201-NRTN-S02-_-WH	02/02	2.00	0.079	5.90	0.232
SWR201-NRTN-S03-_-WH	03/03	4.00	0.157	7.90	0.311
SWR201-NRTN-S04-_-WH	04/04	6.00	0.236	9.90	0.390
SWR201-NRTN-S05-_-WH	05/05	8.00	0.315	11.90	0.469
SWR201-NRTN-S06-_-WH	06/06	10.00	0.394	13.90	0.547
SWR201-NRTN-S07-_-WH	07/07	12.00	0.472	15.90	0.626
SWR201-NRTN-S08-_-WH	08/08	14.00	0.551	17.90	0.705
SWR201-NRTN-S09-_-WH	09/09	16.00	0.630	19.90	0.783
SWR201-NRTN-S10-_-WH	10/10	18.00	0.709	21.90	0.862
SWR201-NRTN-S11-_-WH	11/11	20.00	0.787	23.90	0.941
SWR201-NRTN-S12-_-WH	12/12	22.00	0.866	25.90	1.020
SWR201-NRTN-S13-_-WH	13/13	24.00	0.945	27.90	1.098
SWR201-NRTN-S14-_-WH	14/14	26.00	1.024	29.90	1.177
SWR201-NRTN-S15-_-WH	15/15	28.00	1.102	31.90	1.256
SWR201-NRTN-S16-_-WH	16/16	30.00	1.181	33.90	1.335

#### DIMENSIONS

SWR201-NRTN-S\_-SA-WH

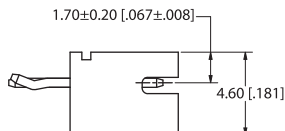
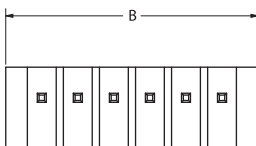
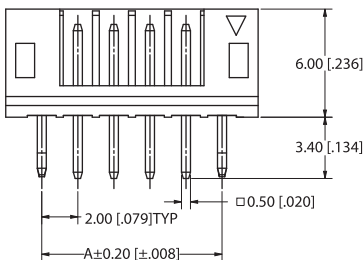

SWR201-NRTN-S\_-RL-WH

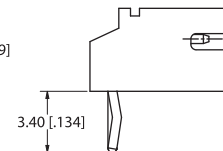
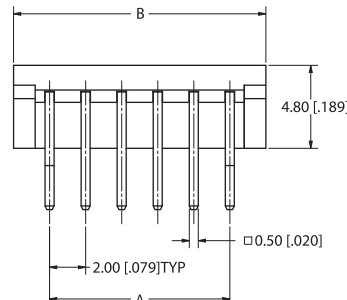
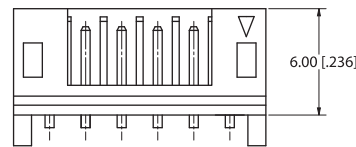



**SWR201 Series Single Row Wafer 2.0mm [.079"] Contact Centers, SMT**

**SPECIFICATIONS**

- Insulator Material: Nylon 6T, UL 94V-0 Color: Beige.
- Contact Material: Brass
- Contact Resistance: 20m OHMs Max.
- Contact Plating: .00020" Min. Nickel Underplate, Pure Tin, Bright Overall.
- Current Rating: 1 AMP per contact
- Dielectric WithStanding Voltage: 800 V AC.
- Insulator Resistance: 1000 Mega OHMS Min.
- Operating Temperature: -25° C TO +85° C.
- Voltage Rating: 125V AC/DC.
- MATES WITH SWH201 SERIES SINGLE ROW HOUSING.

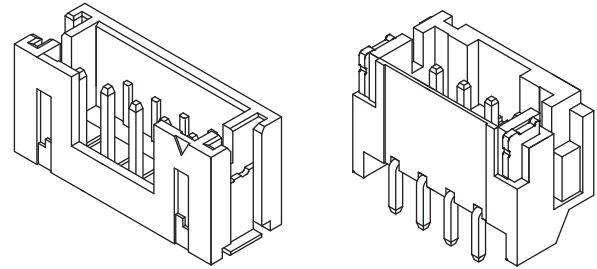

**RECOMMENDED PCB LAYOUT**

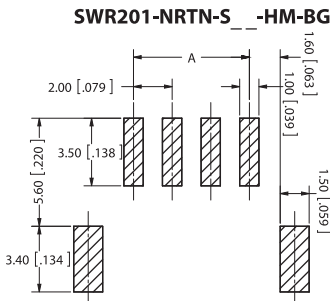
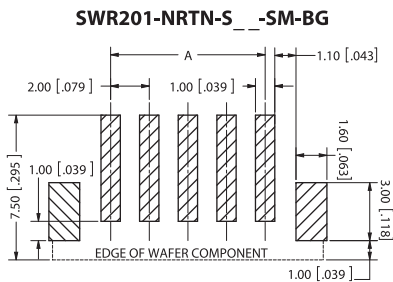

**PART NUMBER CODING**

**SWR201-NRTN-S - -BG**

Number Of Positions \_\_\_\_\_  
(Contacts Per row)

Termination Type

SM = Surface Mount

HM = Horizontal Surface Mount

Part Number	Positions/ Contacts	A		B		C (SM)		C (HM)	
		mm	inch	mm	inch	mm	inch	mm	inch
SWR201-NRTN-S02-__-BG	02/02	2.00	0.079	8.00	0.315	4.60	0.181	4.80	0.189
SWR201-NRTN-S03-__-BG	03/03	4.00	0.157	10.00	0.394	6.60	0.260	6.80	0.268
SWR201-NRTN-S04-__-BG	04/04	6.00	0.236	12.00	0.472	8.60	0.339	8.80	0.346
SWR201-NRTN-S05-__-BG	05/05	8.00	0.315	14.00	0.551	10.60	0.417	10.80	0.425
SWR201-NRTN-S06-__-BG	06/06	10.00	0.394	16.00	0.630	12.60	0.496	12.80	0.504
SWR201-NRTN-S07-__-BG	07/07	12.00	0.472	18.00	0.709	14.60	0.575	14.80	0.583
SWR201-NRTN-S08-__-BG	08/08	14.00	0.551	20.00	0.787	16.60	0.654	16.80	0.661
SWR201-NRTN-S09-__-BG	09/09	16.00	0.630	22.00	0.866	18.60	0.732	18.80	0.740
SWR201-NRTN-S10-__-BG	10/10	18.00	0.709	24.00	0.945	20.60	0.811	20.80	0.819
SWR201-NRTN-S11-__-BG	11/11	20.00	0.787	26.00	1.024	22.60	0.890	22.80	0.898
SWR201-NRTN-S12-__-BG	12/12	22.00	0.866	28.00	1.102	24.60	0.969	24.80	0.976
SWR201-NRTN-S13-__-BG	13/13	24.00	0.945	30.00	1.181	26.60	1.047	26.80	1.055
SWR201-NRTN-S14-__-BG	14/14	26.00	1.024	32.00	1.260	28.60	1.126	28.80	1.134
SWR201-NRTN-S15-__-BG	15/15	28.00	1.102	34.00	1.339	30.60	1.205	30.80	1.213
SWR201-NRTN-S16-__-BG	16/16	30.00	1.181	36.00	1.417	32.60	1.283	32.80	1.291

**DIMENSIONS**

**SWR201-NRTN-S\_\_-SM-BG**

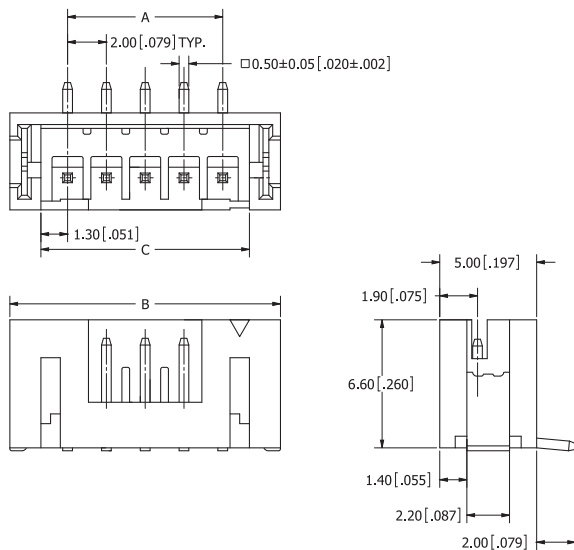

**SWR201-NRTN-S\_\_-HM-BG**

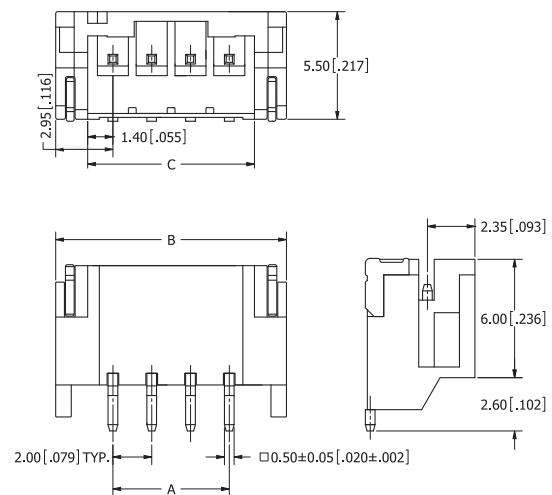



### SWT 204 Series Crimp Terminal

#### SPECIFICATIONS

- Material: Phosphor Bronze.
- Contact Resistance: 10m OHMs Max.
- Current Rating: 3 AMP per contact
- Plating: See Part Number Coding.
- Wire Range: AWG #22 - #26.
- Insulation O.D.:  $\phi$ 1.35mm ~  $\phi$ 1.70mm.
- Quantity Per Reel = 10,000 Pieces.
- Used In SWH204 SERIES Housing.

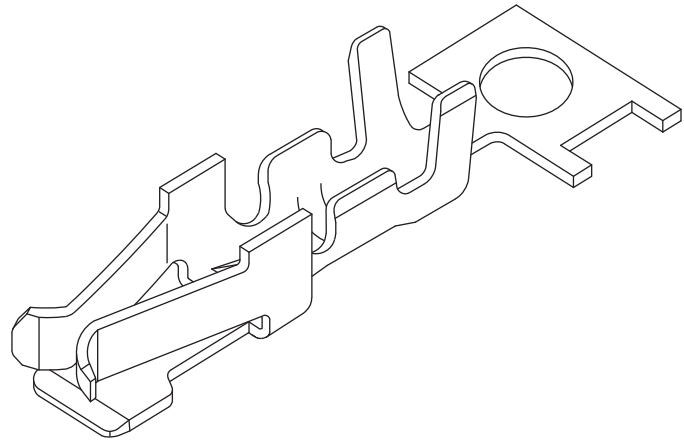

#### PART NUMBER CODING

SWT204-UP N-501-UU-UU

**Plating**

T= .00015" Min Nickel Underplate, .000040" Min Pure Tin, Bright Overall.  
 P= .000040" Min Nickel Underplate, Gold Flash Overall.

#### DIMENSIONS

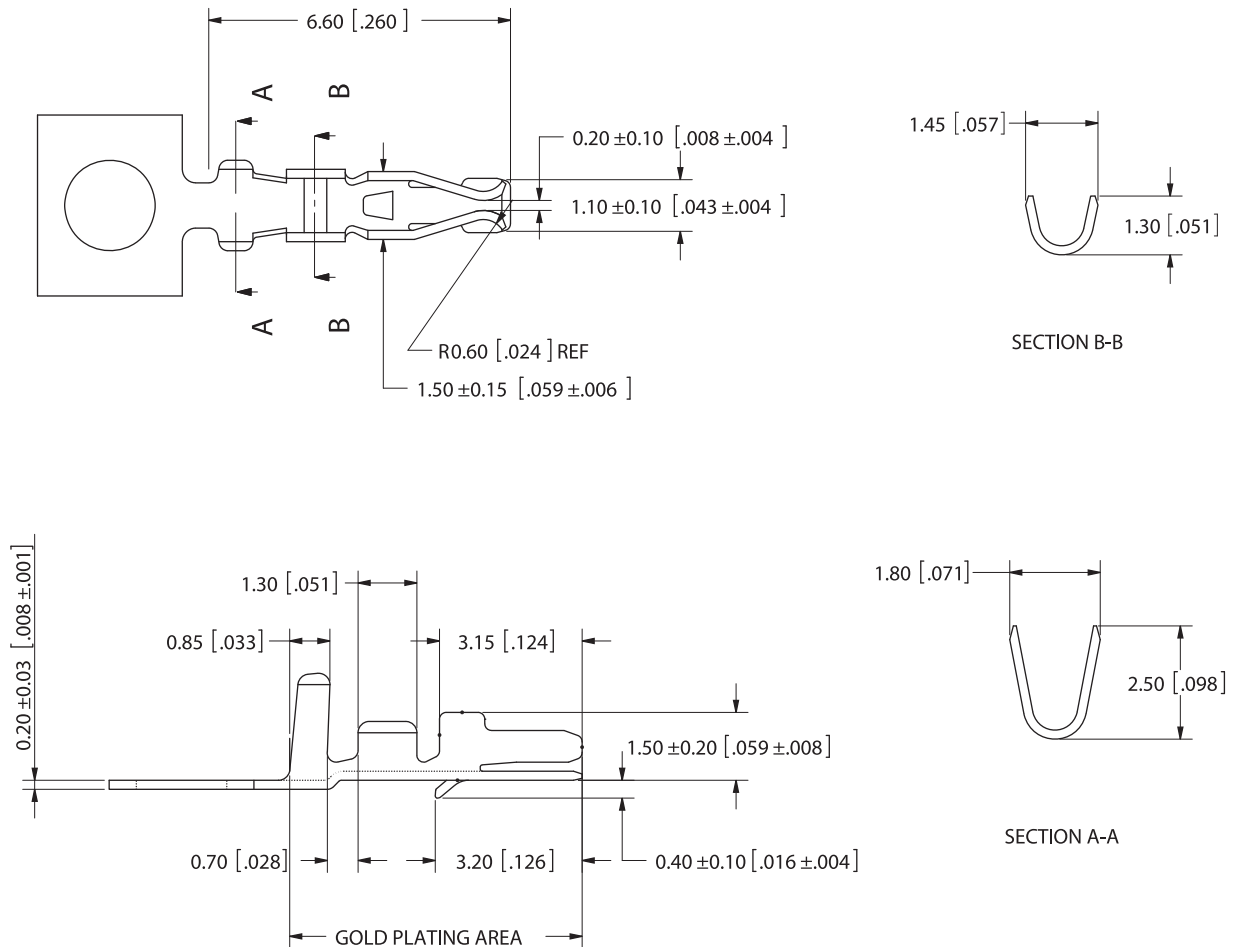



**SWH204 Series Housing 2.0mm[.079"] Contact Centers**

**SPECIFICATIONS**

- Insulator Material: Nylon 66, UL 94V-0 Color: White.
- Dielectric Withstanding Voltage : 800 V AC.
- Insulation Resistance: 1000 Mega OHMS Min.
- Operating Temperature: -25° C TO +85° C.
- Voltage Rating: 50V AC/DC.
- Suitable for SWH204 Series Terminal.
- Mates with SWR204 Series Dual Row Wafer.

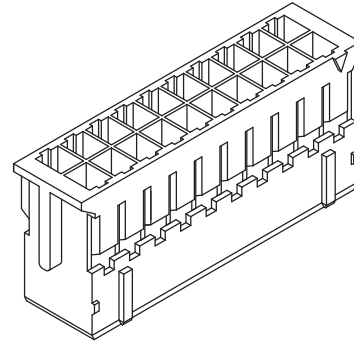

**DIMENSIONS**

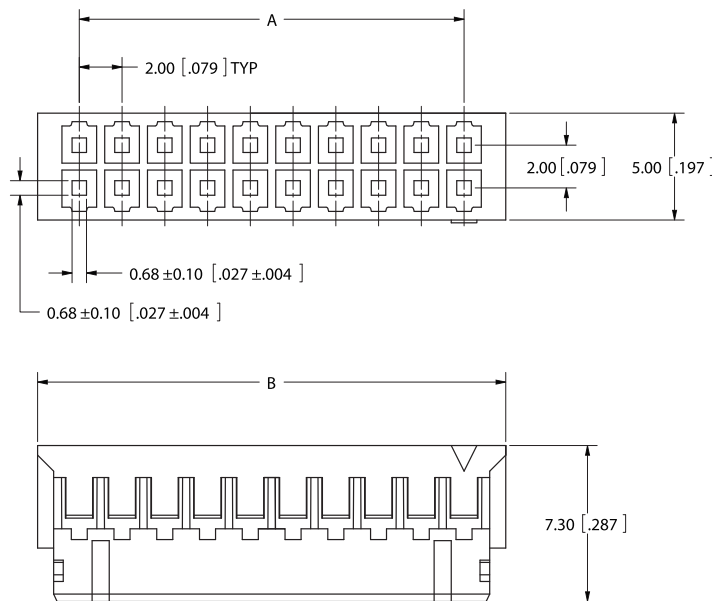

**PART NUMBER CODING**

**SWH204-NULN-D -UU-WH**

**Number Of Positions**  
(Contacts Per row)

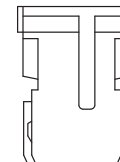

Part Number	Positions/ Contacts	A		B	
		mm	inch	mm	inch
SWH204-NULN-D02-UU-WH	02/04	2.00	0.079	5.90	0.232
SWH204-NULN-D03-UU-WH	03/06	4.00	0.157	7.90	0.311
SWH204-NULN-D04-UU-WH	04/08	6.00	0.236	9.90	0.390
SWH204-NULN-D05-UU-WH	05/10	8.00	0.315	11.90	0.469
SWH204-NULN-D06-UU-WH	06/12	10.00	0.394	13.90	0.547
SWH204-NULN-D07-UU-WH	07/14	12.00	0.472	15.90	0.626
SWH204-NULN-D08-UU-WH	08/16	14.00	0.551	17.90	0.705
SWH204-NULN-D09-UU-WH	09/18	16.00	0.630	19.90	0.783
SWH204-NULN-D10-UU-WH	10/20	18.00	0.709	21.90	0.862
SWH204-NULN-D11-UU-WH	11/22	20.00	0.787	23.90	0.941
SWH204-NULN-D12-UU-WH	12/24	22.00	0.866	25.90	1.020
SWH204-NULN-D13-UU-WH	13/26	24.00	0.945	27.90	1.098
SWH204-NULN-D14-UU-WH	14/28	26.00	1.024	29.90	1.177
SWH204-NULN-D15-UU-WH	15/30	28.00	1.102	31.90	1.256
SWH204-NULN-D16-UU-WH	16/32	30.00	1.181	33.90	1.335
SWH204-NULN-D17-UU-WH	17/34	32.00	1.260	35.90	1.413
SWH204-NULN-D20-UU-WH	20/40	38.00	1.496	41.90	1.650



### SWR204 Series Dual Row Wafer 2.0mm [.079"] Contact Centers, Straight/Right Angle

#### SPECIFICATIONS

- Insulator Material: Nylon 66, UL 94V-0 Color: Grey
- Contact Material: Brass.
- Contact Resistance: 10m OHMs Max.
- Contact Plating: .000020" Min. Nickel Underplate, Pure Tin, Bright Overall.
- Current Rating: 3 AMP per contact
- Dielectric WithStanding Voltage: 800 V AC.
- Insulation Resistance: 1000 Mega OHMS Min.
- Operating Temperature: -25° C TO +85° C.
- Voltage Rating: 50V AC/DC.
- Mates with SWH204 Series Dual Row Housing.

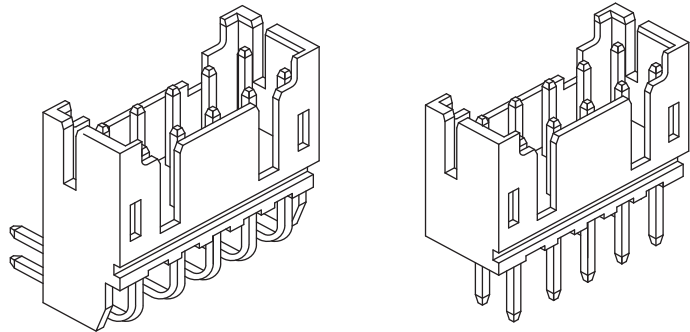

#### DIMENSIONS

SWR204-NRTN-D\_\_-ST-GA

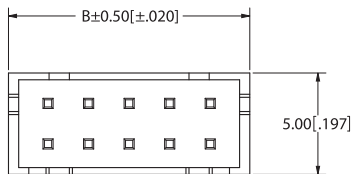

SWR204-NRTN-D\_\_-RA-GA

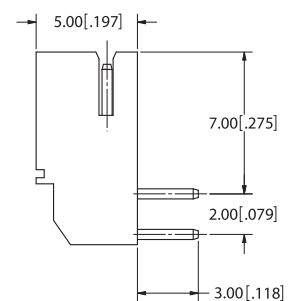
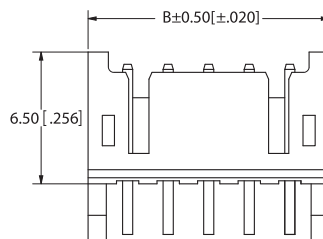
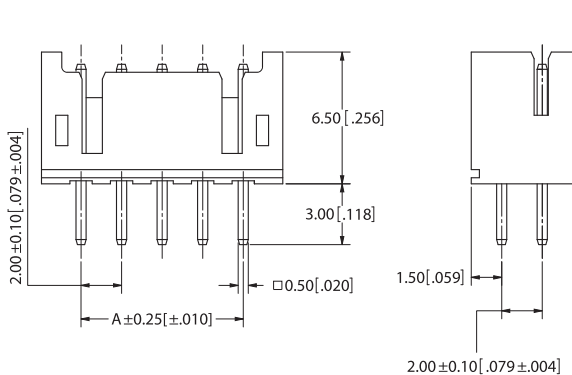
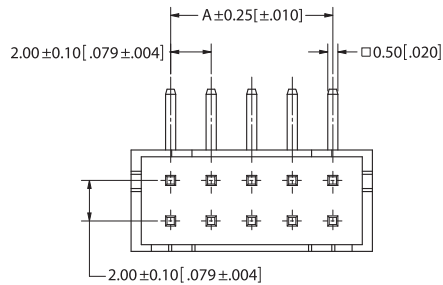



**SWR204 Series Dual Row Wafer 2.0mm [.079"] Contact Centers, Straight/Right Angle**

**PART NUMBER CODING**

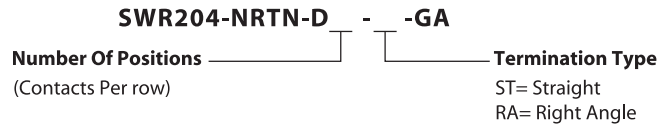

**RECOMMENDED PCB LAYOUT**

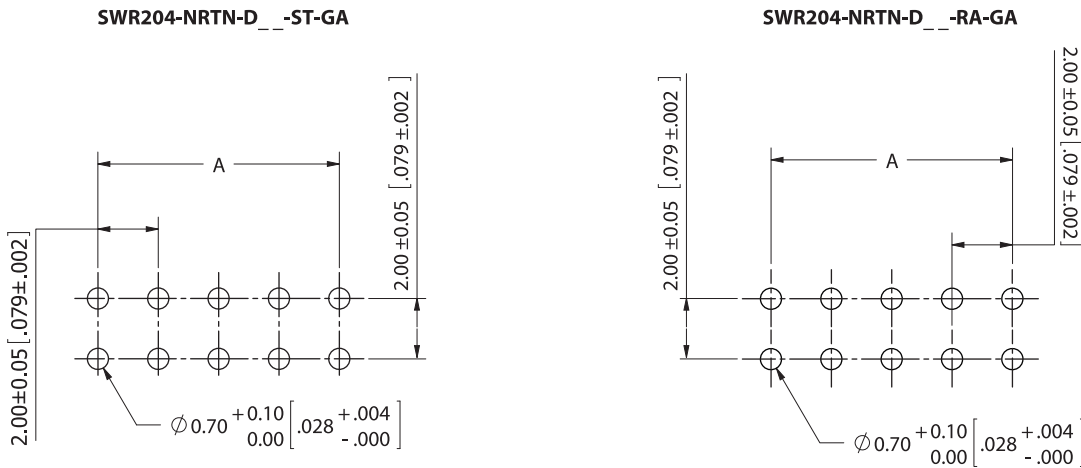

P.C. BOARD THICKNESS: 0.80 ~ 1.60mm [.031" ~ .063"]

Part Number	Positions/Contacts	A		B	
		mm	inch	mm	inch
SWR204-NRTN-D02-__-GA	02/04	2.00	0.079	5.90	0.232
SWR204-NRTN-D03-__-GA	03/06	4.00	0.157	7.90	0.311
SWR204-NRTN-D04-__-GA	04/08	6.00	0.236	9.90	0.390
SWR204-NRTN-D05-__-GA	05/10	8.00	0.315	11.90	0.469
SWR204-NRTN-D06-__-GA	06/12	10.00	0.394	13.90	0.547
SWR204-NRTN-D07-__-GA	07/14	12.00	0.472	15.90	0.626
SWR204-NRTN-D08-__-GA	08/16	14.00	0.551	17.90	0.705
SWR204-NRTN-D09-__-GA	09/18	16.00	0.630	19.90	0.783
SWR204-NRTN-D10-__-GA	10/20	18.00	0.709	21.90	0.862
SWR204-NRTN-D11-__-GA	11/22	20.00	0.787	23.90	0.941
SWR204-NRTN-D12-__-GA	12/24	22.00	0.866	25.90	1.020
SWR204-NRTN-D13-__-GA	13/26	24.00	0.945	27.90	1.098
SWR204-NRTN-D14-__-GA	14/28	26.00	1.024	29.90	1.177
SWR204-NRTN-D15-__-GA	15/30	28.00	1.102	31.90	1.256
SWR204-NRTN-D16-__-GA	16/32	30.00	1.181	33.90	1.335
SWR204-NRTN-D17-__-GA	17/34	32.00	1.260	35.90	1.413
SWR204-NRTN-D20-__-GA	20/40	38.00	1.496	41.90	1.650

Sullins Wafers



### SWT25X Series Crimp Terminal

#### SPECIFICATIONS

- Material: See Part Number Coding
- Contact Resistance: 20m OHMs Max.
- Current Rating: 2.5 AMPS per contact
- Plating: See Part Number Coding.
- Wire Range: AWG #20 - #26.
- Insulation O.D.:  $\varnothing 1.35\text{mm} \sim \varnothing 1.90\text{mm}$ .
- Quantity Per Reel = 10,000 Pieces.
- Used In SWH25X Series Housing.

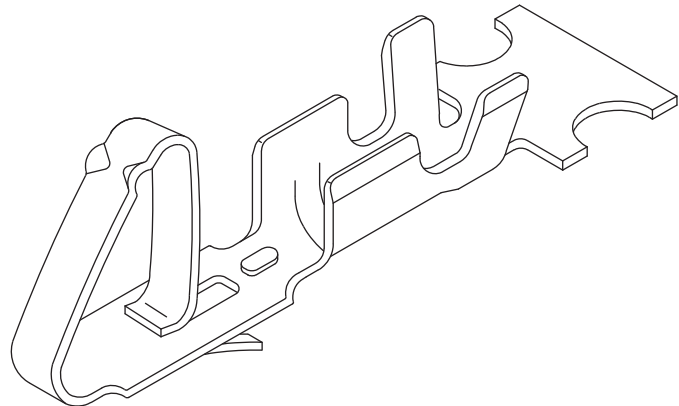

#### PART NUMBER CODING

**SWT25X-U**    **C-S01-UU-UU**

##### Material & Plating

RT= Brass, .000015" Min Nickel Underplate, .000040" Min Pure Tin, Bright Overall.

PT= Phosphor Bronze, .000015" Min Nickel Underplate, .000040" Min Pure Tin, Bright Overall.

RP= Brass, .000040" Min Nickel Underplate, Gold Flash Overall.

#### DIMENSIONS

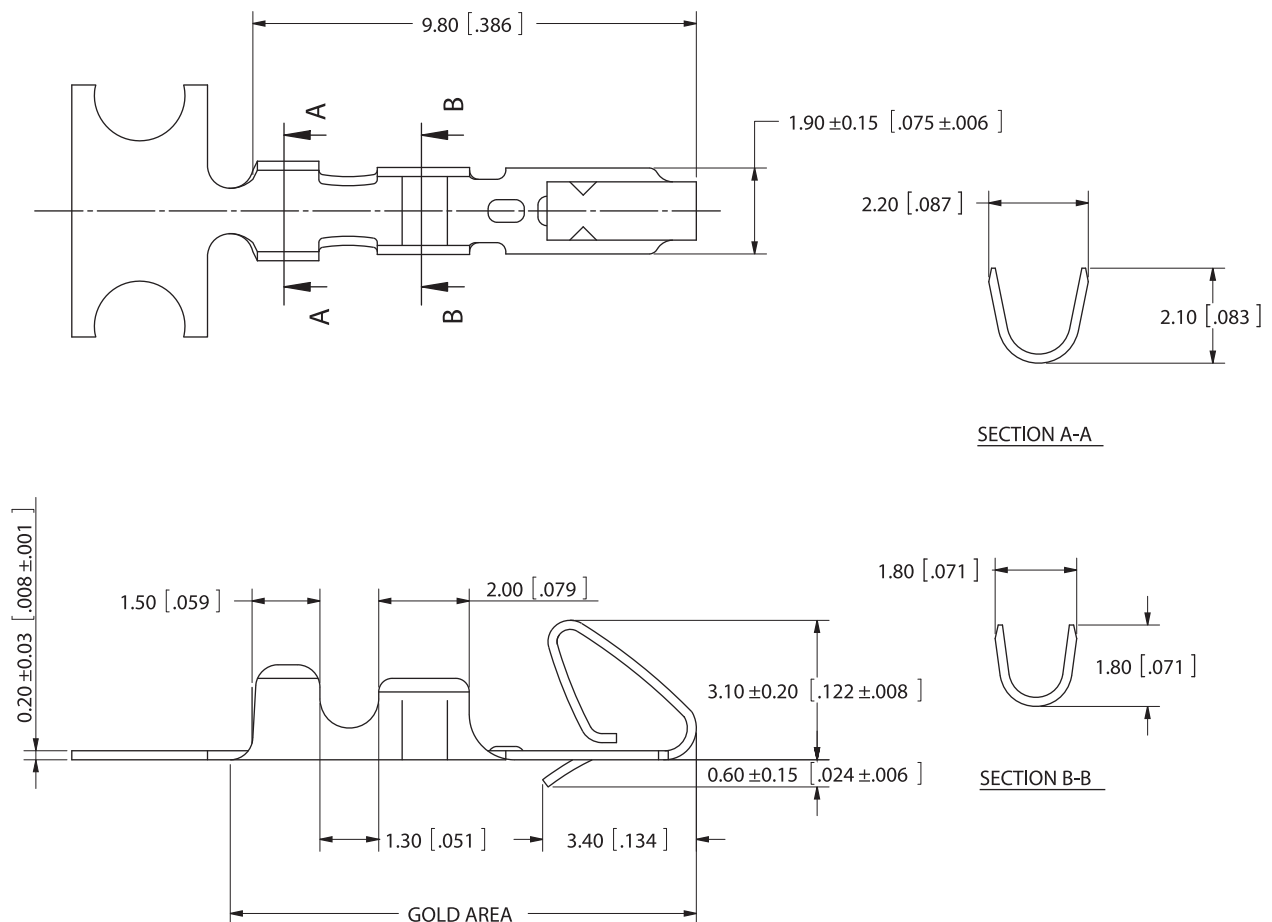



**SWH25X Series Housing 2.54mm [.100"] Contact Centers**

**SPECIFICATIONS**

- Insulator Material: Nylon 66, UL 94V-0 Color: Beige.
- Dielectric WithStanding Voltage: 1000 V AC.
- Insulation Resistance: 1000 Mega OHMS Min.
- Operating Temperature: -25° C TO +85° C.
- Voltage Rating: 250V AC/DC.
- Suitable for SWT25X Series Terminal.
- Mates with SWR25X Series Single Row Wafer.

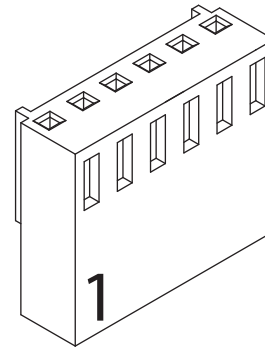

**DIMENSIONS**

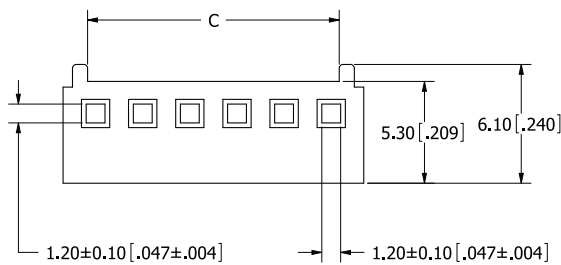

**PART NUMBER CODING**

**SWH25X-NULC-S -UU-BA**

**Number Of Positions**  
(Contacts Per row)

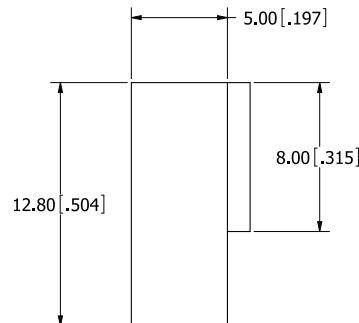
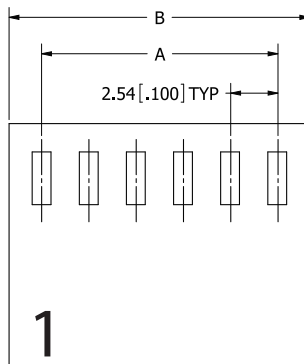

Part Number	Positions/ Contacts	A		B		C	
		mm	inch	mm	inch	mm	inch
SWH25X-NULC-S02-UU-BA	02/02	2.54	0.100	5.79	0.228	3.07	0.121
SWH25X-NULC-S03-UU-BA	03/03	5.08	0.200	8.33	0.328	5.61	0.221
SWH25X-NULC-S04-UU-BA	04/04	7.62	0.300	10.87	0.428	8.15	0.321
SWH25X-NULC-S05-UU-BA	05/05	10.16	0.400	13.41	0.528	10.69	0.421
SWH25X-NULC-S06-UU-BA	06/06	12.70	0.500	15.95	0.628	13.23	0.521
SWH25X-NULC-S07-UU-BA	07/07	15.24	0.600	18.49	0.728	15.77	0.621
SWH25X-NULC-S08-UU-BA	08/08	17.78	0.700	21.03	0.828	18.31	0.721
SWH25X-NULC-S09-UU-BA	09/09	20.32	0.800	23.57	0.928	20.85	0.821
SWH25X-NULC-S10-UU-BA	10/10	22.86	0.900	26.11	1.028	23.39	0.921
SWH25X-NULC-S11-UU-BA	11/11	25.40	1.000	28.65	1.128	25.93	1.021
SWH25X-NULC-S12-UU-BA	12/12	27.94	1.100	31.19	1.228	28.47	1.121
SWH25X-NULC-S13-UU-BA	13/13	30.48	1.200	33.73	1.328	31.01	1.221
SWH25X-NULC-S14-UU-BA	14/14	33.02	1.300	36.27	1.428	33.55	1.321
SWH25X-NULC-S15-UU-BA	15/15	35.56	1.400	38.81	1.528	36.09	1.421
SWH25X-NULC-S16-UU-BA	16/16	38.10	1.500	41.35	1.628	38.63	1.521
SWH25X-NULC-S17-UU-BA	17/17	40.64	1.600	43.89	1.728	41.17	1.621
SWH25X-NULC-S18-UU-BA	18/18	43.18	1.700	46.43	1.828	43.71	1.721
SWH25X-NULC-S19-UU-BA	19/19	45.72	1.800	48.97	1.928	46.25	1.821
SWH25X-NULC-S20-UU-BA	20/20	48.26	1.900	51.51	2.028	48.79	1.921



### SWR25X Series Single Row Wafer 2.54mm [.100"] Contact Centers, Straight/Right Angle

#### SPECIFICATIONS

- Insulation Material: Nylon 66, UL 94V-0, Color: Beige
- Contact Material: Brass.
- Contact Resistance: 20m OHMs Max.
- Contact Plating: .000020" Min. Nickel Underplate, Pure Tin, Bright Overall.
- Current Rating: 2.5 AMPS per contact
- Dielectric WithStanding Voltage: 1000 V AC.
- Insulation Resistance: 1000 Mega OHMS Min.
- Operating Temperature: -25° C TO +85° C.
- Voltage Rating: 250V AC/DC.
- Mates with SWH25X Series Single Row Housing.

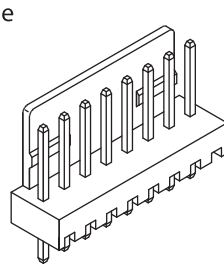

(ST) STRAIGHT

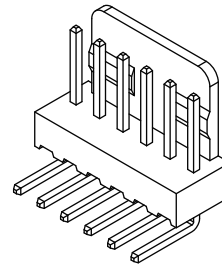

(RA) TYPE 2

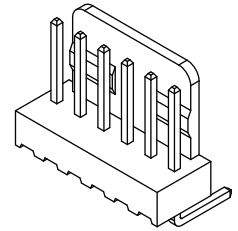

(RB) TYPE 1

#### DIMENSIONS

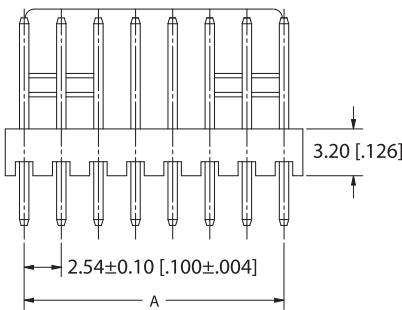
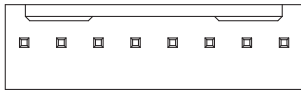

For 06 - 20 POSITIONS

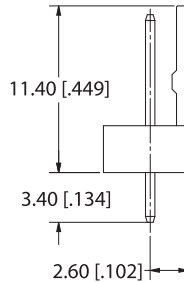

SWR25X-NRTC-S\_\_-ST-BA

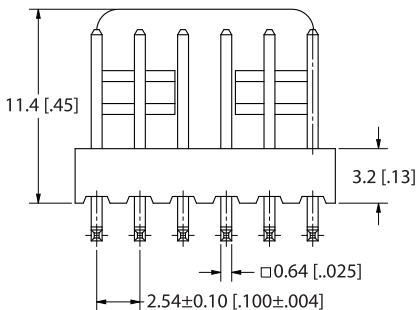
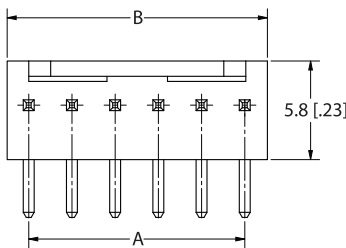

For 06 - 20 POSITIONS

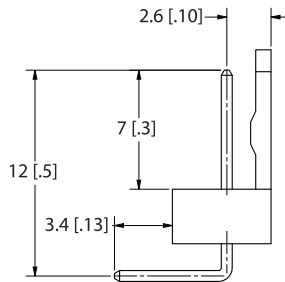

SWR25X-NRTC-S\_\_-RA-BA  
(TYPE 2)

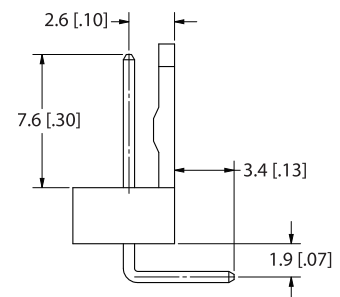

SWR25X-NRTC-S\_\_-RB-BA  
(TYPE 1)



**SWR25X Series Single Row Wafer 2.54mm [.100"] Contact Centers, Straight/Right Angle**

**PART NUMBER CODING**

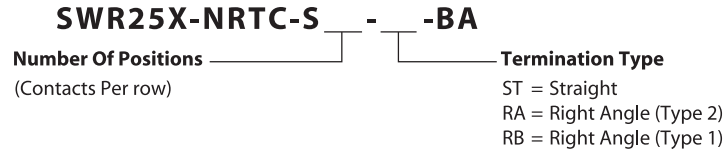

**RECOMMENDED PCB LAYOUT**

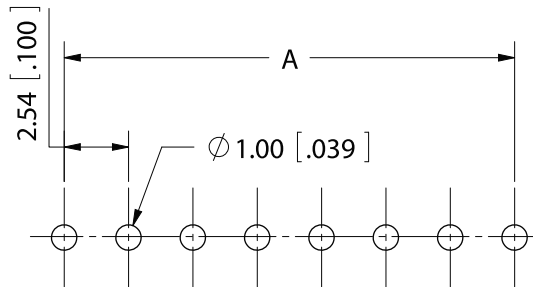

P.C. BOARD THICKNESS: 1.60mm [.063"]

Part Number	Positions/Contacts	A		B	
		mm	inch	mm	inch
SWR25X-NRTC-S02-__-BA	02/02	2.54	0.100	5.12	0.202
SWR25X-NRTC-S03-__-BA	03/03	5.08	0.200	7.66	0.302
SWR25X-NRTC-S04-__-BA	04/04	7.62	0.300	10.20	0.402
SWR25X-NRTC-S05-__-BA	05/05	10.16	0.400	12.74	0.502
SWR25X-NRTC-S06-__-BA	06/06	12.70	0.500	15.30	0.602
SWR25X-NRTC-S07-__-BA	07/07	15.24	0.600	17.94	0.706
SWR25X-NRTC-S08-__-BA	08/08	17.78	0.700	20.48	0.806
SWR25X-NRTC-S09-__-BA	09/09	20.32	0.800	23.02	0.906
SWR25X-NRTC-S10-__-BA	10/10	22.86	0.900	25.58	1.007
SWR25X-NRTC-S11-__-BA	11/11	25.40	1.000	28.12	1.107
SWR25X-NRTC-S12-__-BA	12/12	27.94	1.100	30.68	1.208
SWR25X-NRTC-S13-__-BA	13/13	30.48	1.200	33.10	1.303
SWR25X-NRTC-S14-__-BA	14/14	33.02	1.300	35.80	1.409
SWR25X-NRTC-S15-__-BA	15/15	35.56	1.400	38.34	1.509
SWR25X-NRTC-S16-__-BA	16/16	38.10	1.500	40.94	1.612
SWR25X-NRTC-S17-__-BA	17/17	40.64	1.600	43.30	1.705
SWR25X-NRTC-S18-__-BA	18/18	43.18	1.700	45.90	1.807
SWR25X-NRTC-S19-__-BA	19/19	45.72	1.800	48.56	1.912
SWR25X-NRTC-S20-__-BA	20/20	48.26	1.900	50.80	2.000

Sullins Wafers



**D-Sub Solder Cup Type - 100 SERIES**

**SPECIFICATIONS**

**Material**

- Insulator: Glass-Filled Thermoplastic PBT, UL 94V-0
- Contact: Brass
- Clinch Nut: Brass, Nickel Plated
- Screwlock: Steel, Nickel Plated

**Electrical**

- Contact Resistance: 20m OHMs Max at 1 Amp DC.
- Insulation Resistance: 1000 MagOHMs at 500 VDC.
- Dielectric withstanding Voltage: 1000 Vac/Rms 60Hz for 1 Minute
- Current Rating: 3 Amps
- Voltage Rating: 250 Vac/Rms 60Hz
- Operating Temperature: -55°C to +105°C
- Accepts Wire Size: 22 AWG MAX.

**DIMENSIONS**

**9,15,25,37 Positions**

(PN EXAMPLE: SDS100-PRW2-M09-SN00-1)

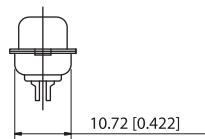

**50 Positions**

(PN EXAMPLE: SDS100-PRW2-M50-SN00-1)

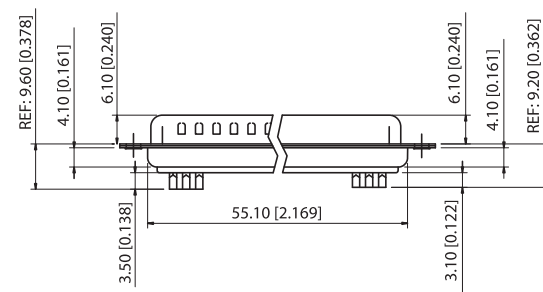
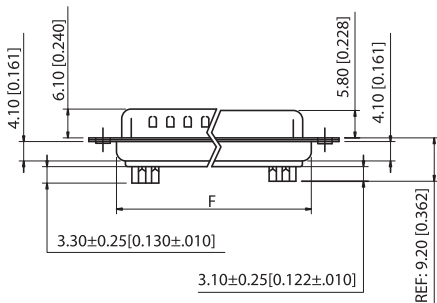
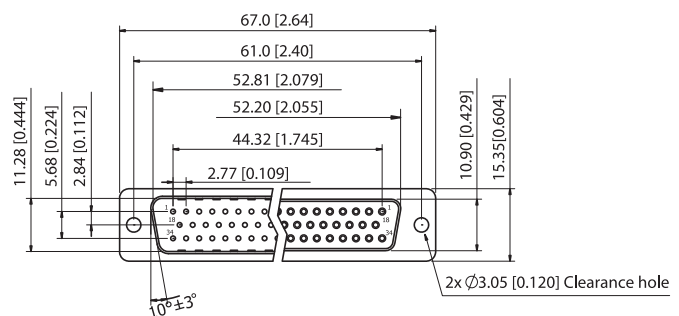
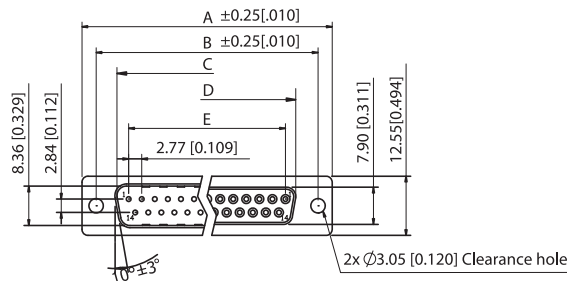
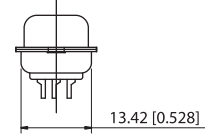

Positions	A		B		C		D		E		F	
	mm	inch	mm	inch	mm	inch	mm	inch	mm	inch	mm	inch
<b>9</b>	30.81	1.213	24.99	0.984	16.92	0.666	16.33	0.643	11.08	0.436	19.20	0.756
<b>15</b>	39.20	1.543	33.30	1.311	25.25	0.994	24.70	0.972	19.39	0.763	27.70	1.091
<b>25</b>	53.05	2.088	47.04	1.852	38.96	1.534	38.40	1.512	33.24	1.309	41.10	1.618
<b>37</b>	69.40	2.732	63.50	2.500	55.42	2.182	54.80	2.158	49.86	1.963	57.30	2.256

Sullins D-Subs



**D-Sub Solder Cup Type - SDS100 SERIES**

**PART NUMBER OPTIONS**

**SDS100-PR** a b c d e f g h i

**a. CONTACT PLATING**

(All Platings Have .000050" Nickel Underplate)

- W = Gold Flash On Contact Surface, .000100" Pure Tin On Termination.
- B = .000010" Gold On Contact Surface, .000100" Pure Tin On Termination.
- U = .000015" Gold On Contact Surface, .000100" Pure Tin On Termination.
- C = .000030" Gold On Contact Surface, .000100" Pure Tin On Termination.
- P = Gold Flash Overall.

**b. SHELL PLATING**

- 1 = Nickel
- 2 = Tin (Standard)

**c. CONTACT TYPE**

- M = MALE
- F = FEMALE

**d. NO. OF PINS**

- 09 = 09 POSITIONS
- 15 = 15 POSITIONS
- 25 = 25 POSITIONS
- 37 = 37 POSITIONS
- 50 = 50 POSITIONS

**e. PIN TYPE**

- S = STAMPED PIN
- M = MACHINED PIN (Available With "P" Plating Only)

**f. FERRITE**

- N = Without Ferrite

**g. FLANGE MOUNTING OPTION**

- 0 =  $\varnothing 3.05\text{mm}$  [ $\varnothing .120$ ] Clearance Hole
- 1 = #4-40 Female Thread
- 4 = M3 Female Thread
- 8 = #4-40 UNC (5.0 X 10.0mm [0.20 X 0.39]) Female Screwlock Installed
- 9 = #4-40 UNC (5.0 X 10.0mm [0.20 X 0.39]) Female Screwlock Bulk-Packed

**h. POSITION OF CLINCH NUT**

(REFER TO BELOW FIGURE FOR DETAIL)

- 0 =  $\varnothing 3.05\text{mm}$  [ $\varnothing .120$ ] Clearance Hole
- 1 = Front Rivet, 5.9mm[0.23]
- 2 = Rear Rivet, 5.9mm[0.23]

**i. INSULATOR COLOR**

- 1 = Black (Standard) 2 = Blue
- 6 = White

**POSITION OF CLINCH NUT** Consult sales or factory for other mounting style options

**h : 0  $\varnothing 3.05\text{mm}$  [ $\varnothing .120$ ] Clearance Hole**

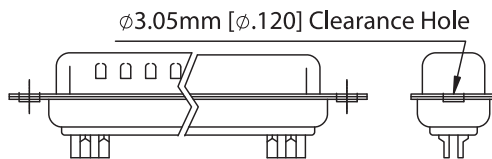

**h : 2 Rear Rivet, 5.9mm[0.23]**

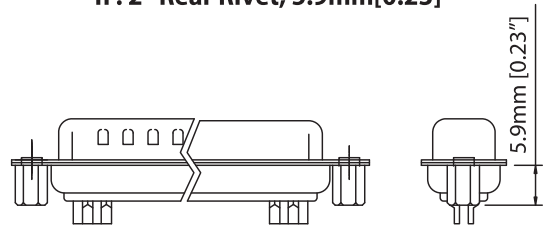

**h : 1 Front Rivet, 5.9mm[0.23]**

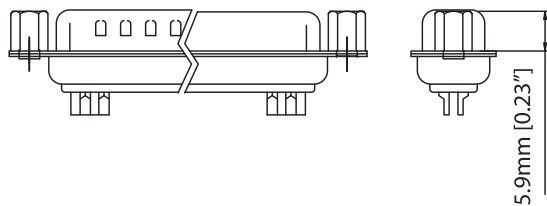



**D-Sub Dip Straight Type - 101 SERIES**

**SPECIFICATIONS**

**Material**

- Insulator: Glass-Filled Thermoplastic PBT, UL 94V-0
- Contact: Brass
- Clinch Nut: Brass, Nickel Plated
- Boardlock: Brass, Tin Plated
- Screwlock: Steel, Nickel Plated

**Electrical**

- Contact Resistance: 20m OHMs Max at 1 Amp DC.
- Insulation Resistance: 1000 MagOHMs at 500 VDC.
- Dielectric withstanding Voltage: 1000 Vac/Rms 60Hz for 1 Minute
- Current Rating: 3 Amps
- Voltage Rating: 250 Vac/Rms 60Hz
- Operating Temperature: -55°C to +105°C

**DIMENSIONS**

**9,15,25,37 Positions**

(PN EXAMPLE: SDS101-PRW2-M09-SN00-1)

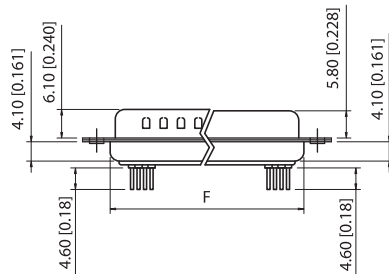
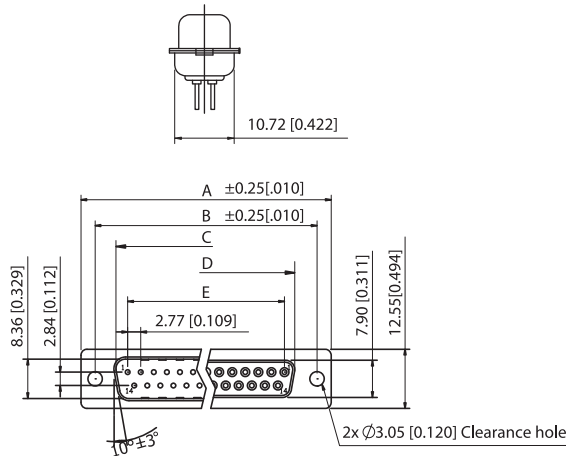

**50 Positions**

(PN EXAMPLE: SDS101-PRW2-M50-SN00-1)

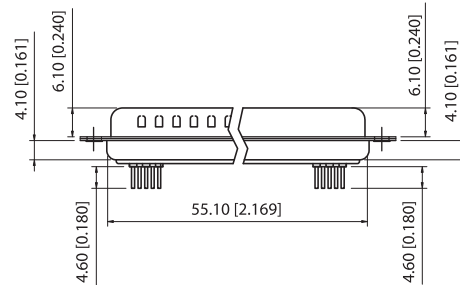
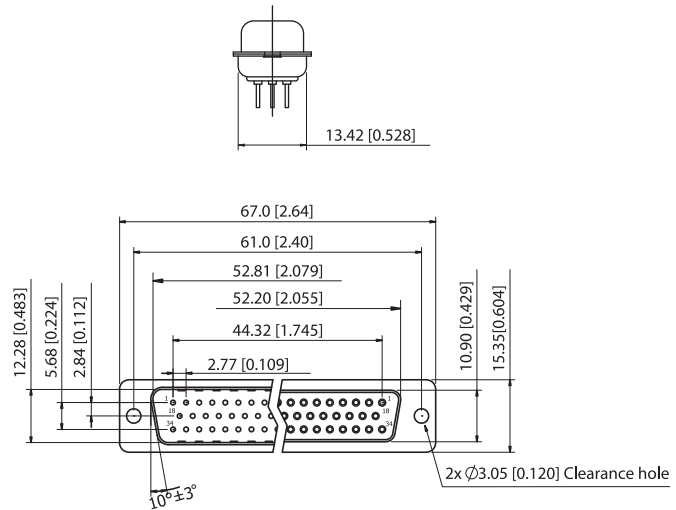

Positions	A		B		C		D		E		F	
	mm	inch	mm	inch	mm	inch	mm	inch	mm	inch	mm	inch
<b>9</b>	30.81	1.213	24.99	0.984	16.92	0.666	16.33	0.643	11.08	0.436	19.20	0.756
<b>15</b>	39.20	1.543	33.30	1.311	25.25	0.994	24.70	0.972	19.39	0.763	27.70	1.091
<b>25</b>	53.05	2.088	47.04	1.852	38.96	1.534	38.40	1.512	33.24	1.309	41.10	1.618
<b>37</b>	69.40	2.732	63.50	2.500	55.42	2.182	54.80	2.158	49.86	1.963	57.30	2.256

Sullins D-Subs



**D-Sub Dip Straight Type - 101 SERIES**

**PART NUMBER OPTIONS**

**SDS101-PR**  $\frac{\text{a}}{\text{b}} - \frac{\text{c}}{\text{d}} - \frac{\text{N}}{\text{e f g h i}}$

**a. CONTACT PLATING**

(All Platings Have .000050" Nickel Underplate)

- W = Gold Flash On Contact Surface, .000100" Pure Tin On Termination.
- B = .000010" Gold On Contact Surface, .000100" Pure Tin On Termination.
- U = .000015" Gold On Contact Surface, .000100" Pure Tin On Termination.
- C = .000030" Gold On Contact Surface, .000100" Pure Tin On Termination.
- P = Gold Flash Overall.

**b. SHELL PLATING**

- 1 = Nickel
- 2 = Tin (Standard)

**c. CONTACT TYPE**

- M = MALE
- F = FEMALE

**d. NO. OF PINS**

- 09 = 09 POSITIONS
- 15 = 15 POSITIONS
- 25 = 25 POSITIONS
- 37 = 37 POSITIONS
- 50 = 50 POSITIONS

**e. PIN TYPE**

- S = STAMPED PIN
- M = MACHINED PIN (Available With "P" Plating Only)

**f. FERRITE**

- N = Without Ferrite

**g. FLANGE MOUNTING OPTION**

- 0 =  $\phi 3.05\text{mm}$  [ $\phi .120$ ] Clearance Hole
- 1 = #4-40 Female Thread
- 4 = M3 Female Thread
- 5 = M3 (5.0 X 10.0mm [0.20 X 0.39]) Female Screwlock Installed
- 8 = #4-40 UNC (5.0 X 10.0mm [0.20 X 0.39]) Female Screwlock Installed
- 9 = #4-40 UNC (5.0 X 10.0mm [0.20 X 0.39]) Female Screwlock Bulk-Packed

**h. POSITION OF CLINCH NUT**

(REFER TO BELOW FIGURE FOR DETAIL)

- 0 =  $\phi 3.05\text{mm}$  [ $\phi .120$ ] Clearance Hole
- 1 = Front Rivet, 5.9mm[0.23]
- 2 = Rear Rivet, 5.9mm[0.23]
- 3 = Rivet+2 Prong Boardlock  $\phi 3.2 \times 6.0 \text{ L}$  [0.13 x 0.24]

**i. INSULATOR COLOR**

- 1 = Black (Standard) 2 = Blue
- 6 = White

**POSITION OF CLINCH NUT** Consult sales or factory for other mounting style options

**h : 0  $\phi 3.05\text{mm}$  [ $\phi .120$ ] Clearance Hole**

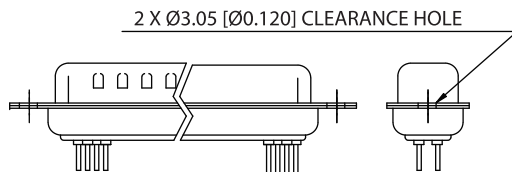

**h : 2 Rear Rivet, 5.9mm[0.23]**

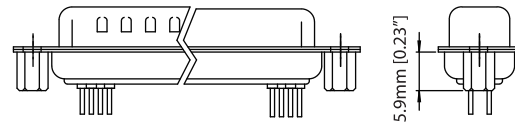

**h : 1 Front Rivet, 5.9mm[0.23]**

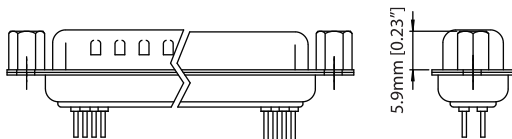

**h : 3 Rivet+2 Prong Boardlock  $\phi 3.2 \times 6.0 \text{ L}$  [0.13 x 0.24]**

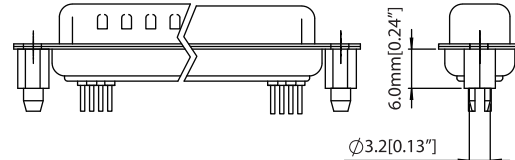

**RECOMMENDED PCB LAYOUT**

**9,15,25,37 Positions**

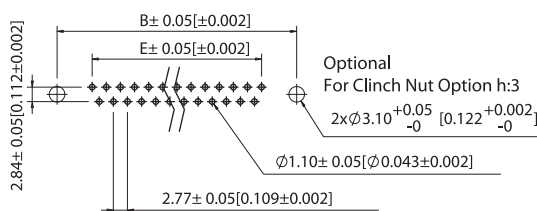

**50 Positions**

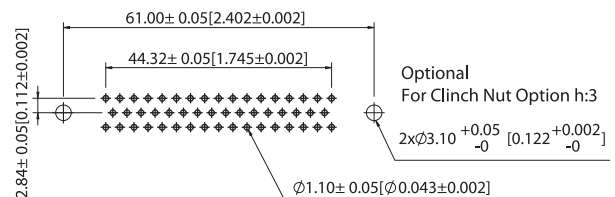



**D-Sub IDC Type - 103 SERIES**

**SPECIFICATIONS**

**Material**

- Insulator: Glass-Filled Thermoplastic PBT, UL 94V-0
- Contact: Brass
- Clinch Nut: Brass, Nickel Plated
- Screwlock: Steel, Nickel Plated

**Electrical**

- Contact Resistance: 20m OHMs Max at 1 Amp DC.
- Insulation Resistance: 1000 MagOHMs at 500 VDC.
- Dielectric withstanding Voltage: 1000 Vac/Rms 60Hz for 1 Minute
- Current Rating: 3 Amps
- Voltage Rating: 250 Vac/Rms 60Hz
- Operating Temperature : -55°C to +105°C
- For 1.27mm [.050"] Pitch Flat Ribbon Cable, 28 AWG.

**DIMENSIONS**

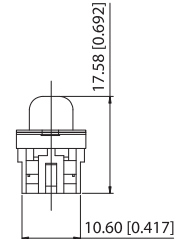
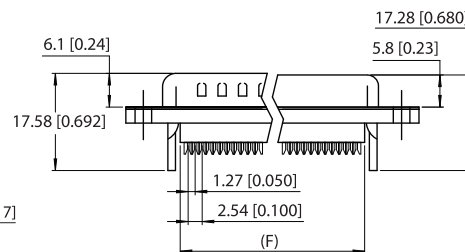
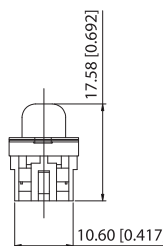
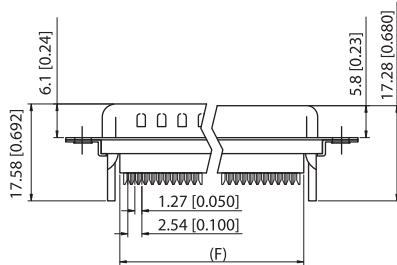
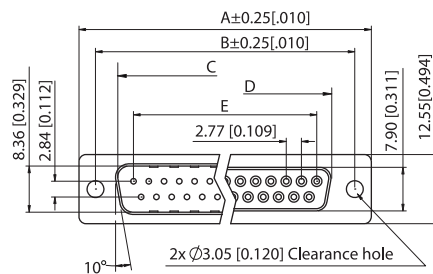
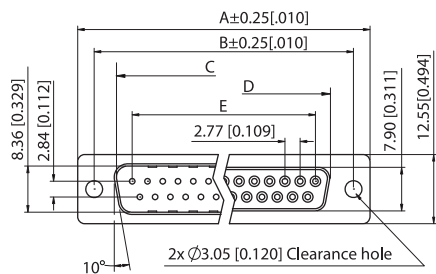

**Without Insulator Support**

(SEE P/N CODING INSULATOR SUPPORT TYPE 2)  
(PN EXAMPLE: SDS103-PRW2-M09-SN00-132)

**With Insulator Support**

(SEE P/N CODING INSULATOR SUPPORT TYPE 1)  
(PN EXAMPLE: SDS103-PRW2-M09-SN00-131)

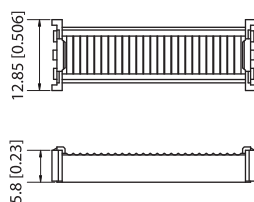

**COVER**

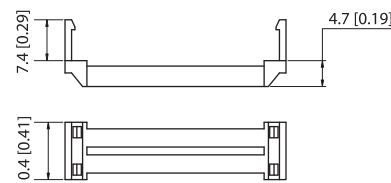

**Strain Relief**

Optional See P/N Coding, ITEM j

Positions	A		B		C		D		E		F	
	mm	inch	mm	inch	mm	inch	mm	inch	mm	inch	mm	inch
<b>9</b>	30.81	1.213	24.99	0.984	16.92	0.666	16.33	0.643	11.08	0.436	13.10	0.516
<b>15</b>	39.20	1.543	33.30	1.311	25.25	0.994	24.70	0.972	19.39	0.763	20.70	0.815
<b>25</b>	53.05	2.088	47.04	1.852	38.96	1.534	38.40	1.512	33.24	1.309	33.68	1.326
<b>37</b>	69.40	2.732	63.50	2.500	55.42	2.182	54.80	2.158	49.86	1.963	50.30	1.980



**PART NUMBER OPTIONS**

**SDS103-PR**  $\frac{\text{a}}{\text{b}}$  -  $\frac{\text{c}}{\text{d}}$  -  $\frac{\text{S}}{\text{e}}$   $\frac{\text{N}}{\text{f}}$   $\frac{\text{0}}{\text{g}}$  -  $\frac{\text{h}}{\text{i}}$   $\frac{\text{j}}{\text{k}}$

**a. CONTACT PLATING**

(All Platings Have .000050" Nickel Underplate)  
 W = Gold Flash On Contact Surface, .000100" Pure Tin On Termination.  
 B = .000010" Gold On Contact Surface, .000100" Pure Tin On Termination.  
 U = .000015" Gold On Contact Surface, .000100" Pure Tin On Termination.  
 C = .000030" Gold On Contact Surface, .000100" Pure Tin On Termination.

**b. SHELL PLATING**

1 = Nickel  
 2 = Tin (Standard)

**c. CONTACT TYPE**

M = MALE  
 F = FEMALE

**d. NO. OF PINS**

09 = 09 POSITIONS  
 15 = 15 POSITIONS  
 25 = 25 POSITIONS  
 37 = 37 POSITIONS

**e. PIN TYPE**

S = STAMPED PIN

**f. FERRITE**

N = Without Ferrite

**g. FLANGE MOUNTING OPTION**

0 =  $\varnothing$ 3.05mm [ $\varnothing$ .120] Clearance Hole  
 1 = #4-40 Female Thread  
 4 = M3 Female Thread  
 7 = M2.6 Female Thread  
 A = #4-40 Female Thread, 4.0mm[0.16] Rear Clinch Nut

**h. POSITION OF CLINCH NUT**

(REFER TO BELOW FIGURE FOR DETAIL)  
 0 = Not Applicable

**i. INSULATOR COLOR**

1 = Black (Standard) 2 = Blue

**j. STRAIN RELIEF TYPE**

1 = Plastic Strain Relief  
 2 = Metal Shell Strain Relief  
 3 = Without Strain Relief

**k. INSULATOR SUPPORT TYPE**

(REFER TO BELOW FIGURE FOR DETAIL)  
 1 = With Insulator Support  
 2 = W/O Insulator Support

**FLANGE MOUNTING OPTION & POSITION OF CLINCH NUT OPTION**

**g : 0, h : 0  $\varnothing$ 3.05mm [ $\varnothing$ .120] Clearance Hole**  
 (available with k=1 or k=2)

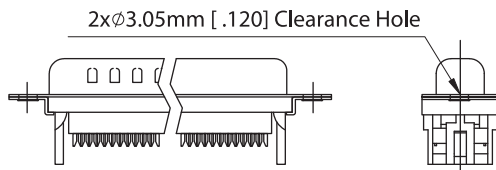

**k = 2 W/O Insulator Support**

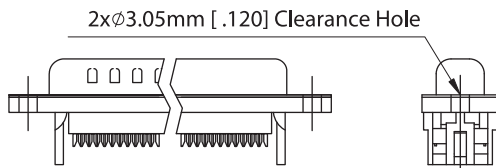

**k = 1 With Insulator Support**

**g : 1, h : 0 #4-40 Female Thread**  
 (available with k=1 only)

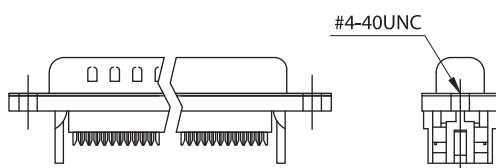

**k = 1 With Insulator Support**

**g : 4, h : 0 M3 Female Thread**  
 (available with k=1 only)

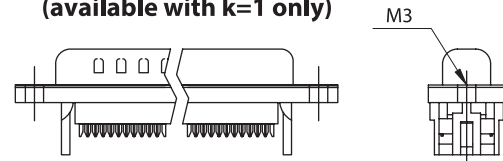

**k = 1 With Insulator Support**

**g : 7, h : 0 M2.6 Female Thread**  
 (available with k=1 only)

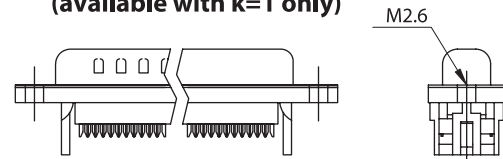

**k = 1 With Insulator Support**

**g : A, h : 0 #4-40 Female Thread, 4.0mm[0.16] Rear Rivet Clinch Nut**  
 (available with k=2 only)

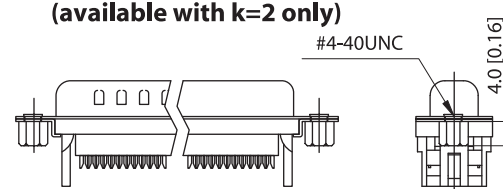

**k = 2 W/O Insulator Support**



**D-Sub HD Solder Cup Type - 104 SERIES**

**SPECIFICATIONS**

**Material**

- Insulator: Glass-Filled Thermoplastic PBT, UL 94V-0
- Contact: Brass
- Clinch Nut: Brass, Nickel Plated
- Screwlock: Steel, Nickel Plated

**Electrical**

- Contact Resistance: 20m OHMs Max at 1 Amp DC.
- Insulation Resistance: 1000 MagOHMs at 500 VDC.
- Dielectric withstanding Voltage: 1000 Vac/Rms 60Hz for 1 Minute
- Current Rating: 3 Amps
- Voltage Rating: 250 Vac/Rms 60Hz
- Operating Temperature: -55°C to +105°C
- Accepts Wire Size: 22 AWG MAX.

**DIMENSIONS**

**15, 26, 44, 62 Positions**

(PN EXAMPLE: SDS104-PRW2-M15-SN00-1)

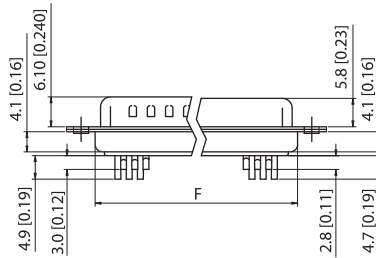
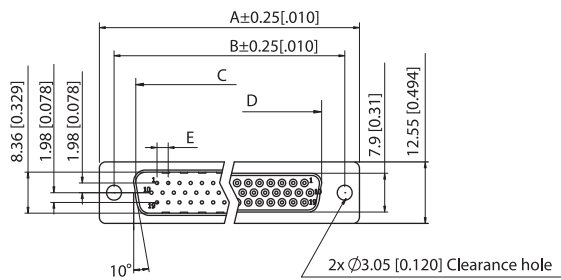
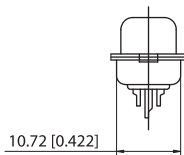

**78 Positions**

(PN EXAMPLE: SDS104-PRW2-M78-SN00-1)

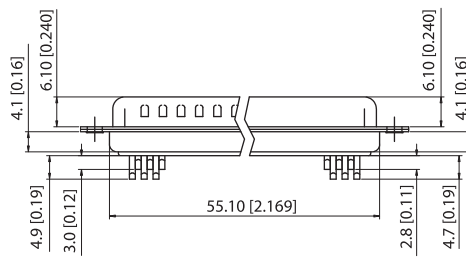
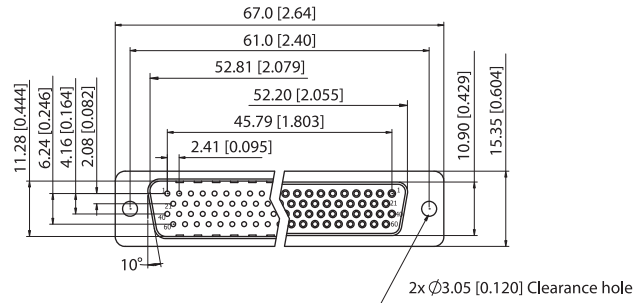
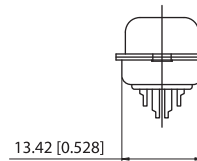

Positions	A		B		C		D		E		F	
	mm	inch	mm	inch	mm	inch	mm	inch	mm	inch	mm	inch
<b>15</b>	30.81	1.213	24.99	0.984	16.92	0.666	16.33	0.643	2.29	0.090	19.20	0.756
<b>26</b>	39.20	1.543	33.30	1.311	25.25	0.994	24.70	0.972	2.29	0.090	27.70	1.091
<b>44</b>	53.05	2.088	47.04	1.852	38.96	1.534	38.40	1.512	2.29	0.090	41.10	1.618
<b>62</b>	69.40	2.732	63.50	2.500	55.42	2.182	54.80	2.158	2.41	0.095	57.30	2.256

Sullins D-Subs





**D-Sub Right Angle Type - 107 SERIES**

**SPECIFICATIONS**

**Material**

- Insulator: Glass-Filled Thermoplastic PBT, UL 94V-0
- Contact: Brass
- Clinch Nut: Brass, Nickel Plated
- Boardlock: Brass, Tin Plated
- Screwlock: Steel, Nickel Plated
- Operating Temperature: -55°C to +105°C

**Electrical**

- Contact Resistance: 20m OHMs Max at 1 Amp DC.
- Insulation Resistance: 1000 MagOHMs at 500 VDC.
- Dielectric withstanding Voltage: 1000 Vac/Rms 60Hz for 1 Minute
- Current Rating: 3 Amps
- Voltage Rating: 250 Vac/Rms 60Hz

**DIMENSIONS**

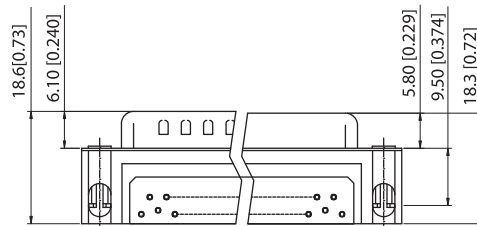
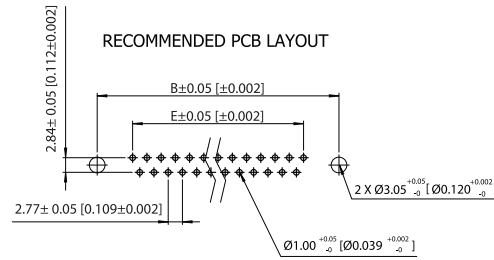
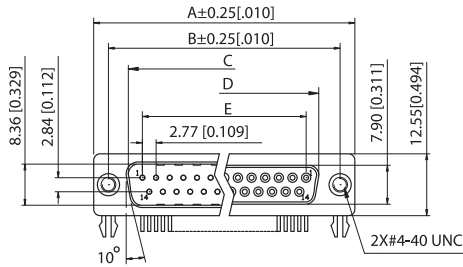

**7.2mm[0.28"] Footprint**

( PN EXAMPLE: SDS107-PRW2-M09-SN13-11 )

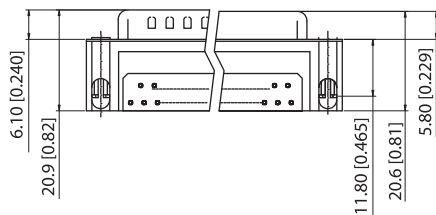
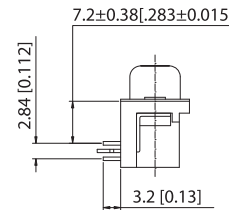

**9.4mm[0.37"] Footprint**

( PN EXAMPLE: SDS107-PRP2-M09-SN13-12 )

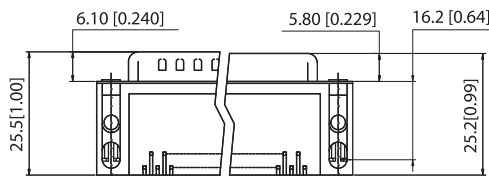
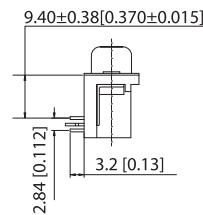

**13.84mm[0.545"] Footprint**

( PN EXAMPLE: SDS107-PRP2-M09-SN13-13 )

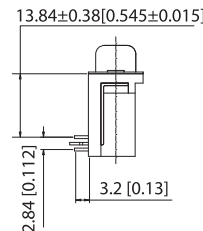

Positions	A		B		C		D		E	
	mm	inch	mm	inch	mm	inch	mm	inch	mm	inch
<b>9</b>	30.81	1.213	24.99	0.984	16.92	0.666	16.33	0.643	11.08	0.436
<b>15</b>	39.20	1.543	33.30	1.311	25.25	0.994	24.70	0.972	19.39	0.763
<b>25</b>	53.05	2.088	47.04	1.852	38.96	1.534	38.40	1.512	33.24	1.309
<b>37</b>	69.40	2.732	63.50	2.500	55.42	2.182	54.80	2.158	49.86	1.963



**D-Sub Right Angle Type - 107 SERIES**

**PART NUMBER OPTIONS**

**SDS107-PR**  $\frac{\quad}{a}$   $\frac{\quad}{b}$   $\frac{\quad}{c}$   $\frac{\quad}{d}$   $\frac{-S}{e}$   $\frac{N}{f}$   $\frac{\quad}{g}$   $\frac{\quad}{h}$   $\frac{-1}{i}$   $\frac{\quad}{j}$

**a. CONTACT PLATING**

(All Platings Have .000050" Nickel Underplate)  
W = Gold Flash On Contact Surface,  
.000100" Pure Tin On Termination.  
P = Gold Flash Overall.

**b. SHELL PLATING**

1 = Nickel  
2 = Tin (Standard)

**c. CONTACT TYPE**

M = MALE  
F = FEMALE

**d. NO. OF PINS**

09 = 09 POSITIONS  
15 = 15 POSITIONS  
25 = 25 POSITIONS  
37 = 37 POSITIONS

**e. PIN TYPE**

S = STAMPED PIN

**f. FERRITE**

N = Without Ferrite

**g. FLANGE MOUNTING OPTION**

0 =  $\varnothing$ 3.05mm [ $\varnothing$ .120] Clearance Hole  
(Combine with h:0 or h:3 only)  
1 = #4-40 Female Thread (Combine with h:1, h:2 or h:3)  
2 = #4-40 UNC (4.8 X 11.8mm [0.19 X 0.46])  
Female Screwlock Installed (Combine with h:1, h:2 or h:3)  
3 = #4-40 UNC (4.8 X 11.8mm [0.19 X 0.46])  
Female Screwlock Bulk-Packed (Combine with h:1, h:2 or h:3)  
\*\* 6 = #4-40 UNC (4.8 X 11.8mm [0.19 X 0.46])  
Female Screwlock Installed (Combine with h:3 only)  
\*\* Remove Screwlock to Disassemble Boardlock Bracket

**h. RIVET OPTIONS**

0 = None  
1 = Grounding Strap On Panel  
2 = Grounding Strap #4-40 Threaded on PCB & PANEL  
3 = Grounding Hook Boardlock+2 Prong

**i. INSULATOR COLOR**

1 = Black (Standard)

**j. FOOTPRINT**

1 = 7.2mm [0.28"] Footprint  
2 = 9.4mm [0.37"] Footprint  
3 = 13.84mm [0.545"] Footprint

**FLANGE MOUNTING OPTION & RIVET OPTIONS**

**g:1 h:3**

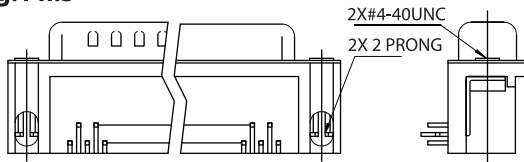

**g:6 h:3**

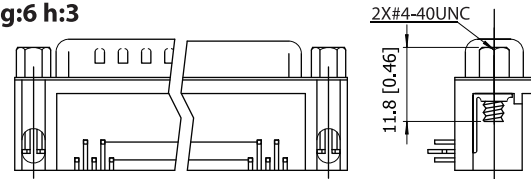

**g:1 h:1**

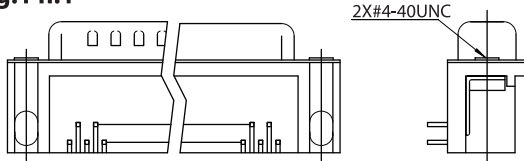

**g:2 h:3**

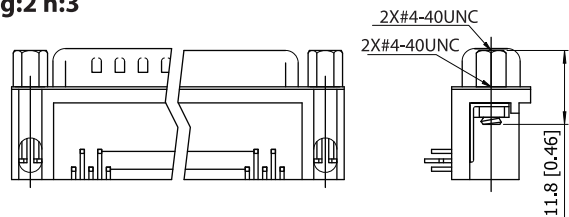

**g:2 h:1**

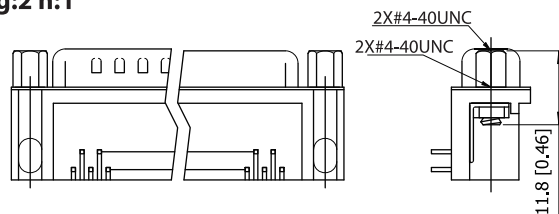

**g:3 h:3**

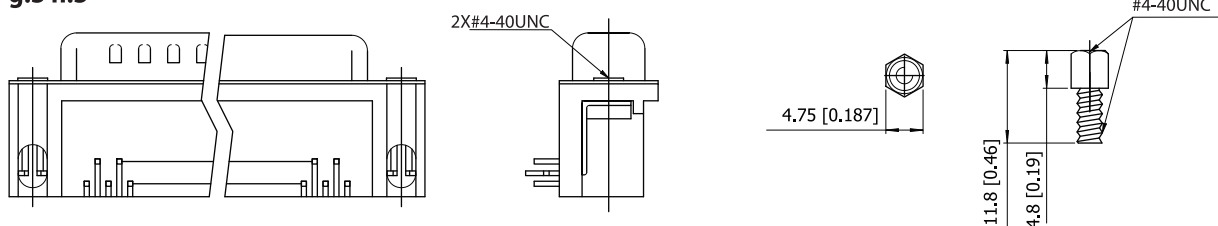



### D-Sub Right Angle Type - 107 SERIES W/O Rear Cover

#### SPECIFICATIONS

##### Material

- Insulator: Glass-Filled Thermoplastic PBT, UL 94V-0
- Contact: Brass
- Clinch Nut: Brass, Nickel Plated
- Boardlock: Brass, Tin Plated
- Screwlock: Steel, Nickel Plated
- Operating Temperature: -55°C to +105°C

##### Electrical

- Contact Resistance: 20m OHMs Max at 1 Amp DC.
- Insulation Resistance: 1000 MagOHMs at 500 VDC.
- Dielectric withstanding Voltage: 1000 Vac/Rms 60Hz for 1 Minute
- Current Rating: 3 Amps
- Voltage Rating: 250 Vac/Rms 60Hz

#### DIMENSIONS

##### 7.2mm[0.28"] Footprint

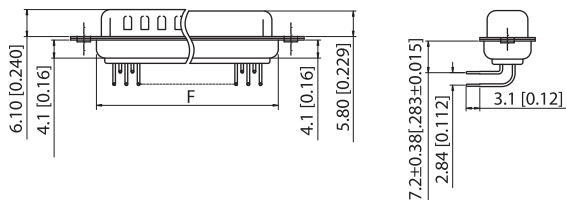
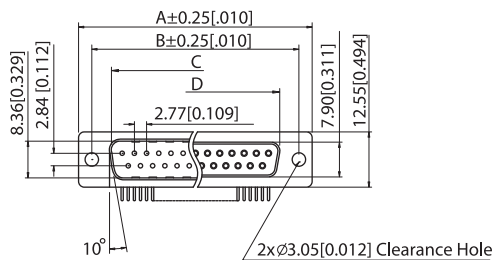

##### 09 thru 37 Positions Machined Pin(W/O Rear Cover)

(PN EXAMPLE: SDS107-PRP2-M09-MN00-11)

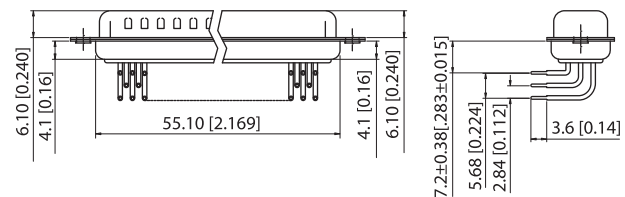
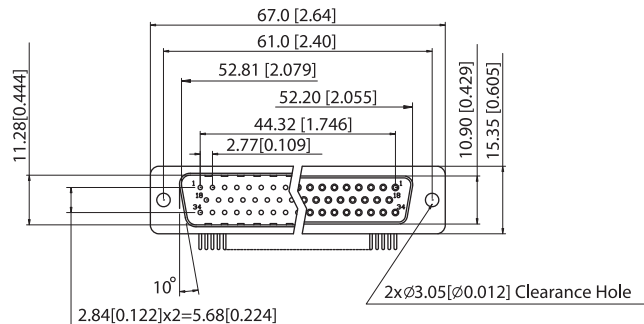

##### 50 Positions Machined Pin (W/O Rear Cover)

(PN EXAMPLE: SDS107-PRP2-M50-MN00-11)

##### 9.4mm[0.37"] Footprint

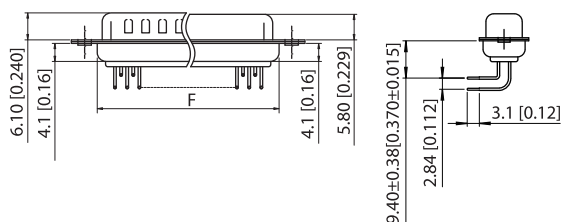
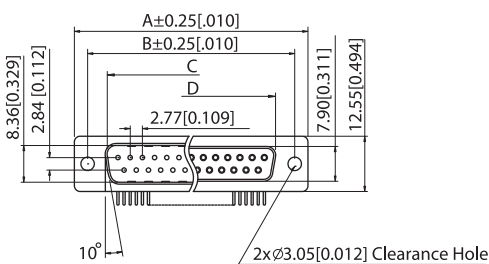

##### 09 thru 37 Positions Machined Pin (W/O Rear Cover)

(PN EXAMPLE: SDS107-PRP2-M09-MN00-12)

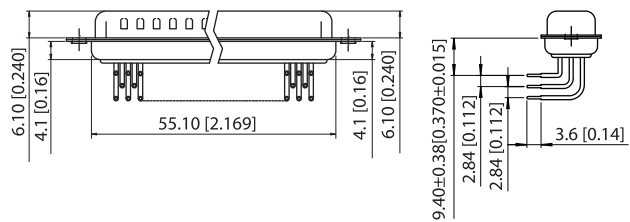
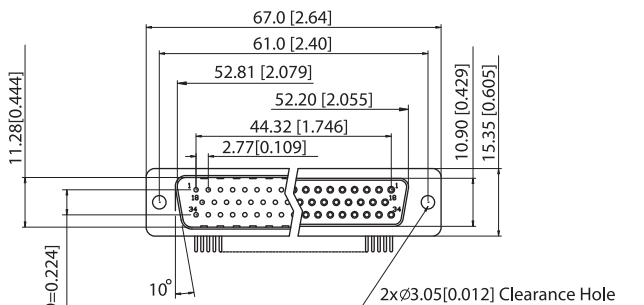

##### 50 Positions Machined Pin (W/O Rear Cover)

(PN EXAMPLE: SDS107-PRP2-M50-MN00-12)



**D-Sub Right Angle Type - 107 SERIES W/O Rear Cover**

**PART NUMBER OPTIONS**

**SDS107-PRP**  $\frac{\text{a}}{\text{b}}$   $\frac{\text{c}}{\text{d}}$  **-MNO0-**  $\frac{\text{e}}{\text{f}}$   $\frac{\text{g}}{\text{h}}$   $\frac{\text{i}}{\text{j}}$

**a. CONTACT PLATING**

P = Gold Flash Overall.

**b. SHELL PLATING**

1 = Nickel  
2 = Tin (Standard)

**c. CONTACT TYPE**

M = MALE  
F = FEMALE

**d. NO. OF PINS**

09 = 09 POSITIONS  
15 = 15 POSITIONS  
25 = 25 POSITIONS  
37 = 37 POSITIONS  
50 = 50 POSITIONS

**e. PIN TYPE**

M = STAMPED PIN

**f. FERRITE**

N = Without Ferrite

**g. FLANGE MOUNTING OPTION**

0 =  $\varnothing 3.05\text{mm}$  [ $\varnothing .120$ ] Clearance Hole

**h. RIVET OPTIONS**

0 = None

**i. INSULATOR COLOR**

1 = Black (Standard)

**j. FOOTPRINT**

1 = 7.2mm [0.28"] Footprint  
2 = 9.4mm [0.37"] Footprint

Positions	A		B		C		D		E		F	
	mm	inch	mm	inch	mm	inch	mm	inch	mm	inch	mm	inch
<b>9</b>	30.81	1.213	24.99	0.984	16.92	0.666	16.33	0.643	11.08	0.436	19.20	0.756
<b>15</b>	39.20	1.543	33.30	1.311	25.25	0.994	24.70	0.972	19.39	0.763	27.70	1.091
<b>25</b>	53.05	2.088	47.04	1.852	38.96	1.534	38.40	1.512	33.24	1.309	41.10	1.618
<b>37</b>	69.40	2.732	63.50	2.500	55.42	2.182	54.80	2.158	49.86	1.963	57.30	2.256

**RECOMMENDED PCB LAYOUT**

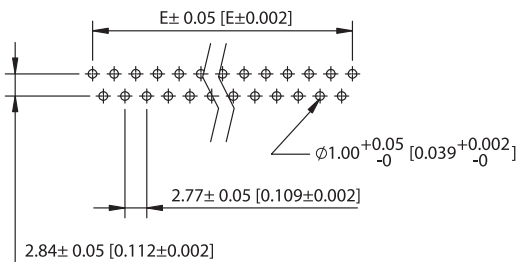

**09 thru 37 Positions Machined Pin (W/O Rear Cover)**

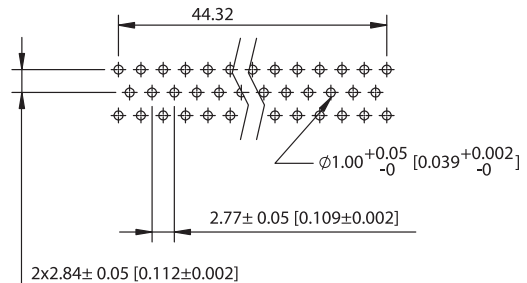

**50 Positions Machined Pin (W/O Rear Cover)**

Sullins DSubs



**D-Sub H.D. Right Angle Type - 108 SERIES**

**SPECIFICATIONS**

**Material**

- Insulator: Glass-Filled Thermoplastic PBT, UL 94V-0
- Contact: Brass
- Clinch Nut: Brass, Nickel Plated
- Boardlock: Brass, Tin Plated
- Screwlock: Steel, Nickel Plated

**Electrical**

- Contact Resistance: 20m OHMs Max at 1 Amp DC.
- Insulation Resistance: 1000 MagOHMs at 500 VDC.
- Dielectric withstanding Voltage: 1000 Vac/Rms 60Hz for 1 Minute
- Current Rating: 3 Amps
- Voltage Rating: 250 Vac/Rms 60Hz
- Operating Temperature : -55°C to +105°C

**DIMENSIONS**

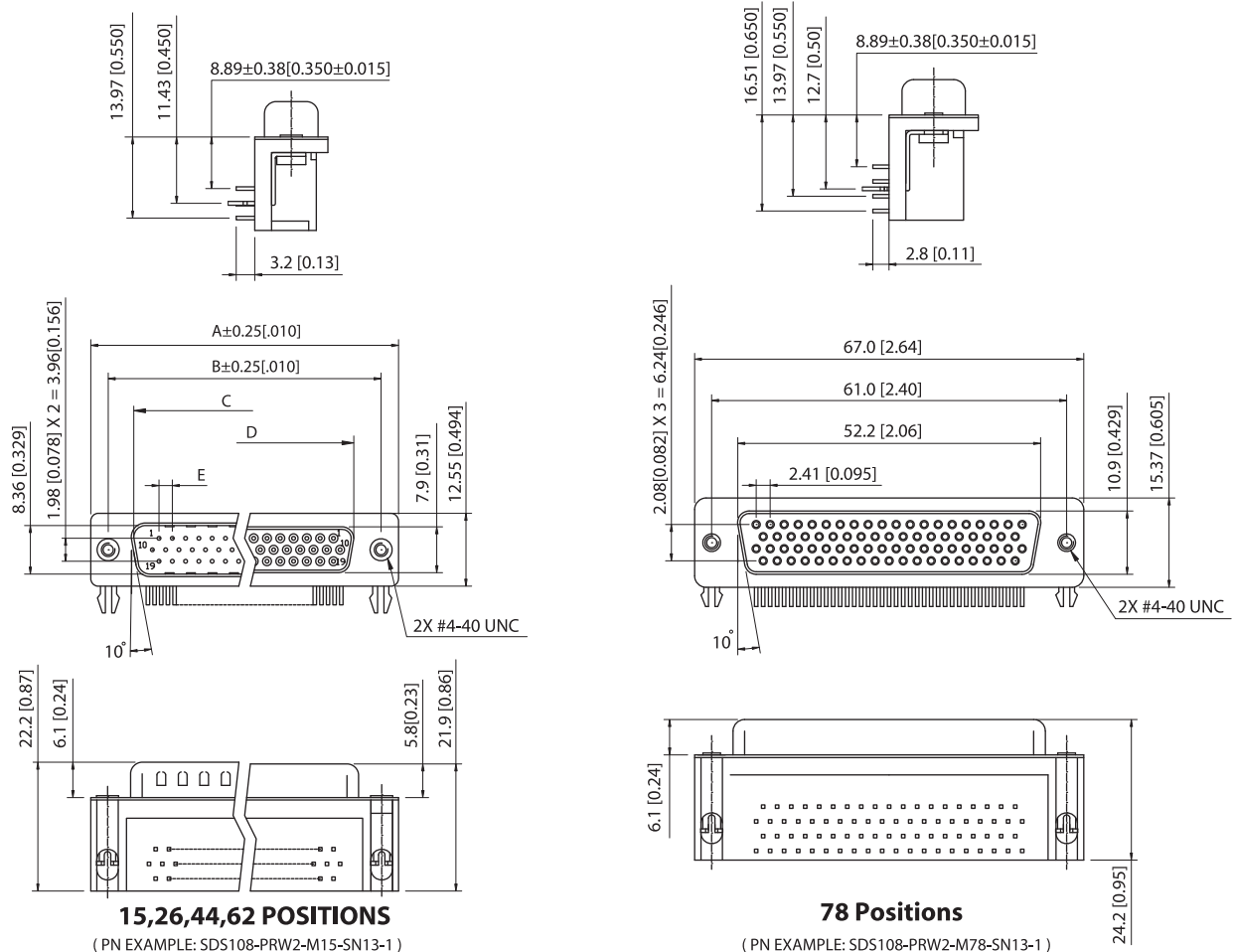

Positions	A		B		C		D		E		F		G	
	mm	inch	mm	inch	mm	inch	mm	inch	mm	inch	mm	inch	mm	inch
<b>15</b>	30.81	1.213	24.99	0.984	16.92	0.666	16.33	0.643	2.29	0.090	7.04	0.277	1.145	0.0451
<b>26</b>	39.20	1.543	33.30	1.311	25.25	0.994	24.70	0.972	2.29	0.090	7.04	0.277	1.145	0.0451
<b>44</b>	53.05	2.088	47.04	1.852	38.96	1.534	38.40	1.512	2.29	0.090	7.04	0.277	1.145	0.0451
<b>62</b>	69.40	2.732	63.50	2.500	55.42	2.182	54.80	2.158	2.41	0.095	7.00	0.276	1.205	0.0474

Sullins D-Subs



**D-Sub H.D. Right Angle Type - 108 SERIES**

**PART NUMBER OPTIONS**

**SDS108-PR**  $\frac{\quad}{a} - \frac{\quad}{b} - \frac{\quad}{c} - \frac{\quad}{d} - \frac{\quad}{e} \frac{\quad}{f} \frac{\quad}{g} \frac{\quad}{h} - \frac{\quad}{i} \mathbf{N} - \mathbf{1}$

**a. CONTACT PLATING**

- (All Platings Have .000050" Nickel Underplate)
- W = Gold Flash On Contact Surface,  
.000100" Pure Tin On Termination.
- U = .000015" Gold On Contact Surface,  
.000100" Pure Tin On Termination.
- C = .000030" Gold On Contact Surface,  
.000100" Pure Tin On Termination.
- P = Gold Flash Overall.

**b. SHELL PLATING**

- 1 = Nickel
- 2 = Tin (Standard)

**c. CONTACT TYPE**

- M = MALE
- F = FEMALE

**d. NO. OF PINS**

- 15 = 15 POSITIONS
- 26 = 26 POSITIONS
- 44 = 44 POSITIONS
- 62 = 62 POSITIONS
- 78 = 78 POSITIONS

**e. PIN TYPE**

- S = STAMPED PIN

**f. FERRITE**

- N = Without Ferrite

**g. FLANGE MOUNTING OPTION**

- 0 =  $\varnothing 3.05\text{mm}$  [ $\varnothing .120$ ] Clearance Hole (Combine with h:0 only)
- 1 = #4-40 Female Thread (Combine with h:1 or h:3)
- 2 = #4-40 UNC (4.8 X 11.8mm [0.19 X 0.46])  
Female Screwlock Installed (Combine with h:1 or h:3)
- 3 = #4-40 UNC (4.8 X 11.8mm [0.19 X 0.46])  
Female Screwlock Bulk-Packed (Combine with h:1 or h:3)
- \*\* 6 = #4-40 UNC (4.8 X 11.8mm [0.19 X 0.46])  
Female Screwlock Installed (Combine with h:3 only)
- \*\* Remove Screwlock to Disassemble Boardlock Bracket

**h. RIVET OPTIONS (REFER TO BELOW FIGURE FOR DETAIL)**

- 0 = None
- 1 = Grounding Strap On Panel
- 3 = Grounding Hook Boardlock+2 Prong

**i. INSULATOR COLOR**

- 1 = Black (Standard)

**FLANGE MOUNTING OPTION & RIVET OPTIONS**

**g : 1, h : 3 Grounding Hook Boardlock+2 Prong**  
(#4-40 Female Thread)

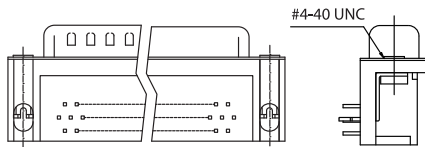

**g : 3, h : 3 Grounding Hook Boardlock+2 Prong**  
(#4-40 UNC (4.8 X 11.8mm [0.19 X 0.46]) Female Screwlock Bulk-Packed)

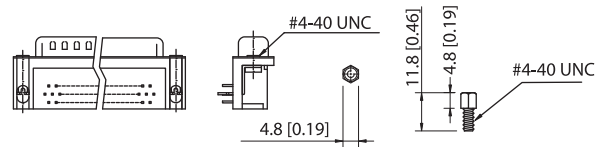

**g : 2, h : 3 Grounding Hook Boardlock+2 Prong**  
(#4-40 UNC (4.8 X 11.8mm [0.19 X 0.46]) Female Screwlock Installed)

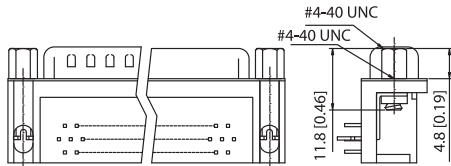

**g : 6, h : 3 Grounding Hook Boardlock+2 Prong**  
(#4-40 UNC (4.8 X 11.8mm [0.19 X 0.46]) Female Screwlock Installed)

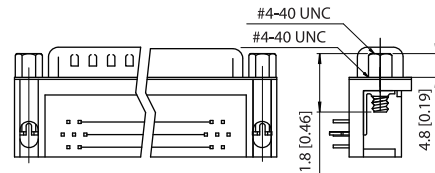

**g : 1, h : 1 Grounding Strap On Panel**  
(#4-40 Female Thread)

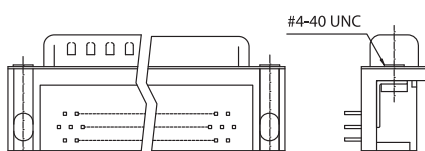

**g : 2, h : 1 Grounding Strap On Panel**  
(#4-40 UNC (4.8 X 11.8mm [0.19 X 0.46]) Female Screwlock Installed)

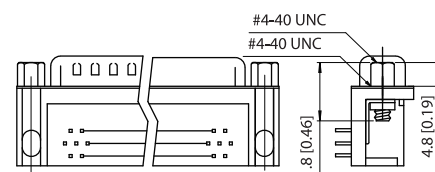

**RECOMMENDED PCB LAYOUT**

**15,26,44,62 Positions Male**

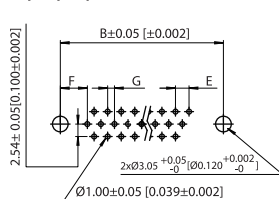

**15,26,44,62 POSITIONS FEMALE**

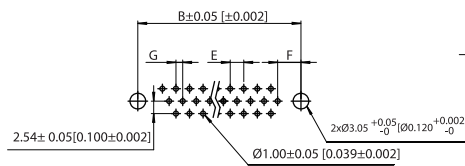

**78 POSITIONS MALE / FEMALE**

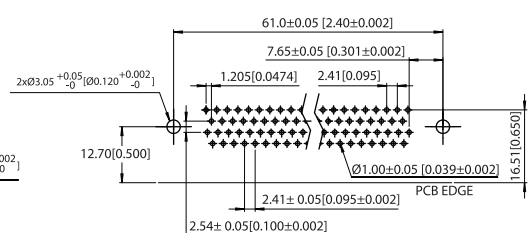



**D-Sub High Profile Straight Type - 155 SERIES**

**SPECIFICATIONS**

**Material**

- Insulator: Glass-Filled Thermoplastic PBT, UL 94V-0
- Contact: Brass
- Clinch Nut: Brass, Nickel Plated
- Boardlock: Brass, Tin Plated
- Screwlock: Steel, Nickel Plated

**Electrical**

- Contact Resistance: 20m OHMs Max at 1 Amp DC.
- Insulation Resistance: 1000 MagOHMs at 500 VDC.
- Dielectric withstanding Voltage: 1000 Vac/Rms 60Hz for 1 Minute
- Current Rating: 3 Amps
- Voltage Rating: 250 Vac/Rms 60Hz
- Operating Temperature : -55°C to +105°C

**DIMENSIONS**

**9,15,25,37 Positions**

(PN EXAMPLE: SDS155-PRW2-M09-QN00-1)

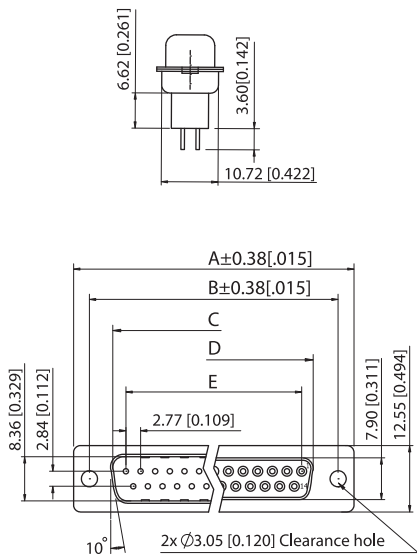

**50 Positions**

(PN EXAMPLE: SDS155-PRW2-M50-QN00-1)

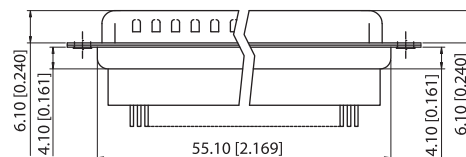
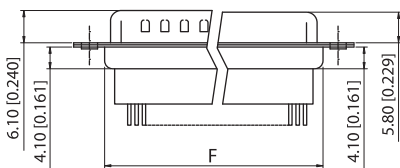
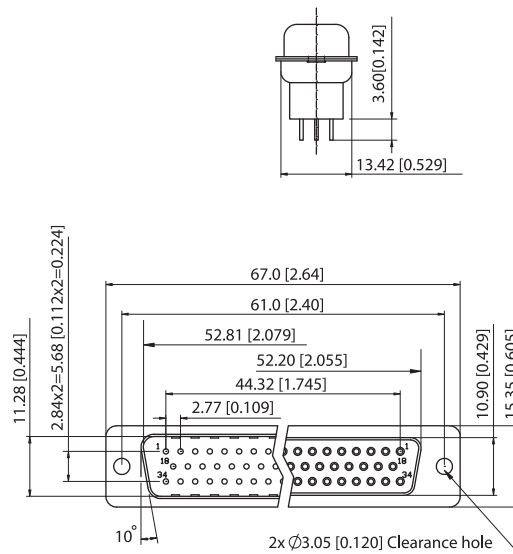

Positions	A		B		C		D		E		F	
	mm	inch	mm	inch	mm	inch	mm	inch	mm	inch	mm	inch
<b>9</b>	30.81	1.213	24.99	0.984	16.92	0.666	16.33	0.643	11.08	0.436	19.20	0.756
<b>15</b>	39.20	1.543	33.30	1.311	25.25	0.994	24.70	0.972	19.39	0.763	27.70	1.091
<b>25</b>	53.05	2.088	47.04	1.852	38.96	1.534	38.40	1.512	33.24	1.309	41.10	1.618
<b>37</b>	69.40	2.732	63.50	2.500	55.42	2.182	54.80	2.158	49.86	1.963	57.30	2.256

Sullins D-Subs



**D-Sub High Profile Straight Type - 155 SERIES**

**PART NUMBER OPTIONS**

**SDS155-PR**  $\frac{\text{a}}{\text{b}}$  -  $\frac{\text{c}}{\text{d}}$  -  $\frac{\text{Q}}{\text{e}}$   $\frac{\text{N}}{\text{f}}$  -  $\frac{\text{g}}{\text{h}}$  -  $\frac{\text{1}}{\text{i}}$

**a. CONTACT PLATING**

(All Platings Have .000050" Nickel Underplate)  
 W = Gold Flash On Contact Surface,  
 .000100" Pure Tin On Termination.  
 U = .000015" Gold On Contact Surface,  
 .000100" Pure Tin On Termination.  
 C = .000030" Gold On Contact Surface,  
 .000100" Pure Tin On Termination.

**b. SHELL PLATING**

1 = Nickel  
 2 = Tin (Standard)

**c. CONTACT TYPE**

M = MALE  
 F = FEMALE

**d. NO. OF PINS**

09 = 09 POSITIONS  
 15 = 15 POSITIONS  
 25 = 25 POSITIONS  
 37 = 37 POSITIONS  
 50 = 50 POSITIONS

**e. PIN TYPE**

Q = STAMPED PIN, TAIL LENGTH= 3.6mm[0.14]

**f. FERRITE**

N = Without Ferrite

**g. FLANGE MOUNTING OPTION**

0 =  $\varnothing 3.05\text{mm}$  [ $\varnothing 0.120$ ] Clearance Hole  
 1 = #4-40 Female Thread  
 8 = #4-40 UNC (5.0 X 10.0mm [0.20 X 0.39])  
 Female Screwlock Installed  
 9 = #4-40 UNC (5.0 X 10.0mm [0.20 X 0.39])  
 Female Screwlock Bulk-Packed

**h. RIVET OPTIONS (REFER TO BELOW FIGURE FOR DETAIL)**

0 =  $\varnothing 3.05\text{mm}$  [ .120] Clearance Hole  
 1 = Front Rivet, 5.9mm[0.23]  
 2 = Rear Rivet, 5.9mm[0.23]  
 4 = Boardlock+2 Prong  $\varnothing 3.0 \times 11.0 \text{ L}$  [0.12 x 0.43]

**i. INSULATOR COLOR**

1 = Black (Standard)

**RIVET OPTIONS**

**h : 0  $\varnothing 3.05\text{mm}$  [ $\varnothing .120$ ] Clearance Hole**

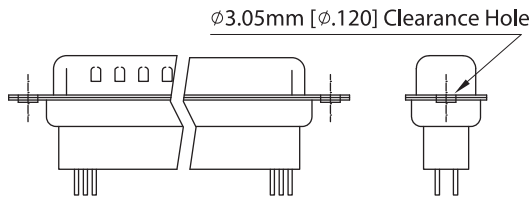

**h : 2 Rear Rivet, 5.9mm[0.23]**

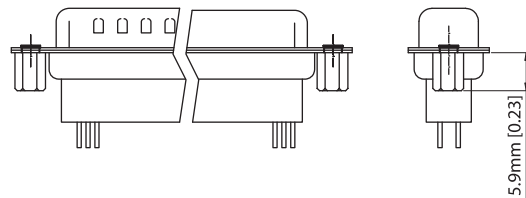

**h : 1 Front Rivet, 5.9mm[0.23]**

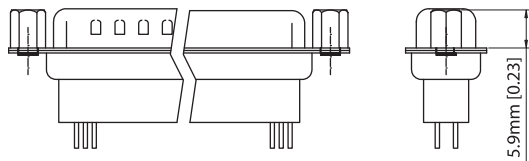

**h : 4 Boardlock+2 Prong  $\varnothing 3.0 \times 11.0 \text{ L}$  [0.12 x 0.43]**

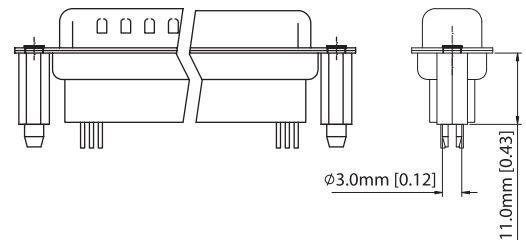

**RECOMMENDED PCB LAYOUT**

**9,15,25,37 Positions**

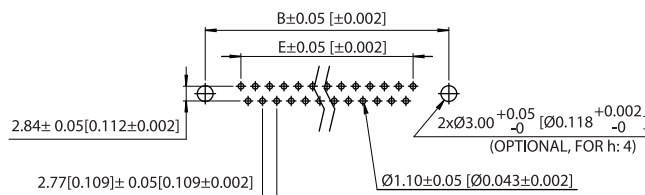

**50 Positions**

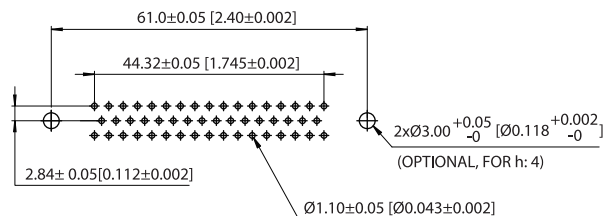



**D-Sub H.D. High Profile PCB Type - 160 SERIES**

**SPECIFICATIONS**

**Material**

- Insulator: Glass-Filled Thermoplastic PBT, UL 94V-0
- Contact: Brass
- Clinch Nut: Brass, Nickel Plated
- Screwlock: Steel, Nickel Plated

**Electrical**

- Contact Resistance: 20m OHMs Max at 1 Amp DC.
- Insulation Resistance: 1000 MagOHMs at 500 VDC.
- Dielectric withstanding Voltage: 1000 Vac/Rms 60Hz for 1 Minute
- Current Rating: 3 Amps
- Voltage Rating: 250 Vac/Rms 60Hz
- Operating Temperature: -55°C to +105°C

**DIMENSIONS**

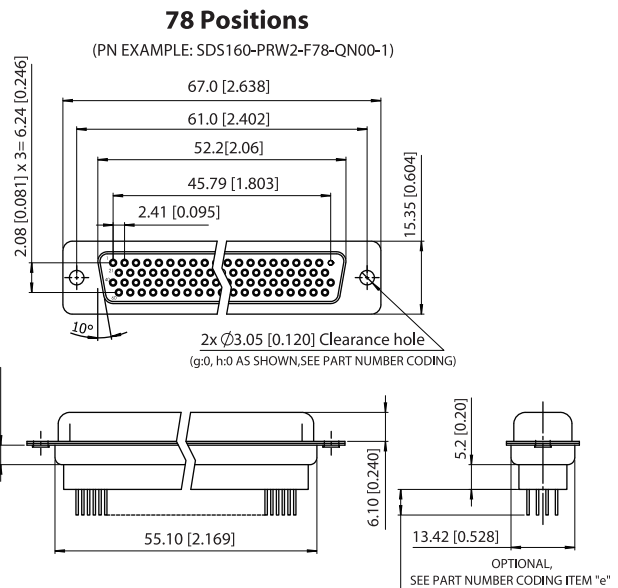
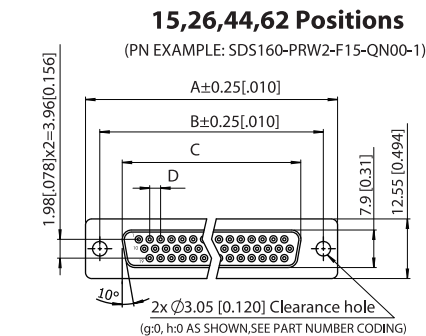

Positions	A		B		C		D		E	
	mm	inch	mm	inch	mm	inch	mm	inch	mm	inch
15	30.81	1.213	24.99	0.984	16.33	0.643	2.29	0.090	19.20	0.756
26	39.20	1.543	33.30	1.311	24.70	0.972	2.29	0.090	27.70	1.091
44	53.05	2.088	47.04	1.852	38.40	1.512	2.29	0.090	41.10	1.618
62	69.40	2.732	63.50	2.500	54.80	2.158	2.41	0.095	57.30	2.256

**RECOMMENDED PCB LAYOUT**

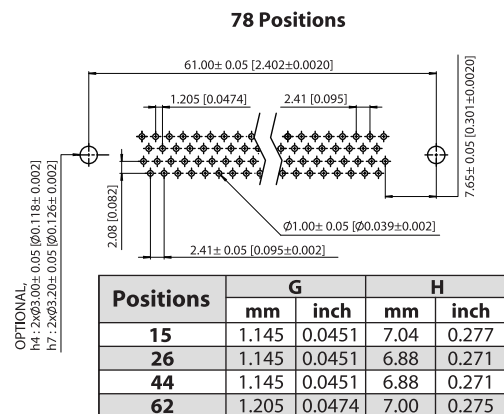
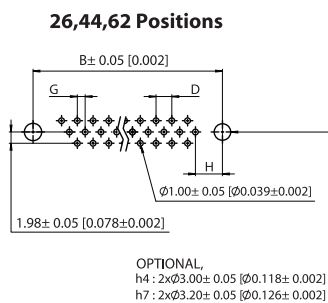
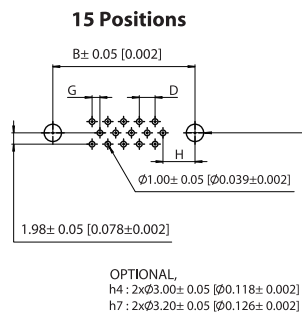



**D-Sub H.D. High Profile PCB Type - 160 SERIES**

**PART NUMBER OPTIONS**

**SDS160-PR**    - **F**    - **N**    -        
a b c d e f g h i

**a. CONTACT PLATING**

(All Platings Have .000050" Nickel Underplate)  
 W = Gold Flash On Contact Surface, .000100" Pure Tin On Termination.  
 B = .000010" Gold On Contact Surface, .000100" Pure Tin On Termination.  
 U = .000015" Gold On Contact Surface, .000100" Pure Tin On Termination.  
 C = .000030" Gold On Contact Surface, .000100" Pure Tin On Termination.

**b. SHELL PLATING**

1 = Nickel  
 2 = Tin (Standard)

**c. CONTACT TYPE**

F = FEMALE

**d. NO. OF PINS**

15 = 15 POSITIONS                      \* 26 = 26 POSITIONS  
 \* 44 = 44 POSITIONS                    \* 62 = 62 POSITIONS  
 \* 78 = 78 POSITIONS                    \* Consult Factory For Availability

**e. PIN TYPE**

Q = STAMPED PIN, TAIL LENGTH = 3.6mm [0.14]  
 U = STAMPED PIN, TAIL LENGTH = 3.0mm [0.12]  
 V = STAMPED PIN, TAIL LENGTH = 5.4mm [0.21]

**f. FERRITE**

N = Without Ferrite

**g. FLANGE MOUNTING OPTION**

0 =  $\phi$ 3.05mm [ $\phi$ .120] Clearance Hole  
 1 = #4-40 Female Thread  
 B = #4-40 UNC (5.8 X 11.8mm [0.23 X 0.46])  
     Female Screwlock Installed  
 C = #4-40 UNC (5.8 X 11.8mm [0.23 X 0.46])  
     Female Screwlock Bulk-Packed  
 D = #4-40 UNC (5.8 X 10.8mm [0.23 X 0.43])  
     Slotted Female Screwlock Bulk-Packed

**h. RIVET OPTIONS**

**(REFER TO BELOW FIGURE FOR DETAIL)**

0 =  $\phi$ 3.05mm [ $\phi$ .120] Clearance Hole  
 1 = Front Rivet, 5.9mm[0.23]  
 2 = Rear Rivet, 5.9mm[0.23]  
 4 = Standoff+2 Prong Boardlock  $\phi$ 3.0 x 11.0Lmm [ $\phi$ 0.12X0.43]  
     (Option e: Pin Type 'V' Only)  
 7 = Standoff+2 Prong Boardlock  $\phi$ 3.2 x 9.6Lmm [ $\phi$ 0.13X0.38]  
     (Option e: Pin Type 'Q' or 'U' Only)

**i. INSULATOR COLOR**

1 = Black (Standard)  
 2 = Blue

**RIVET OPTIONS**

**h : 0  $\phi$ 3.05mm [ $\phi$ .120] Clearance Hole**

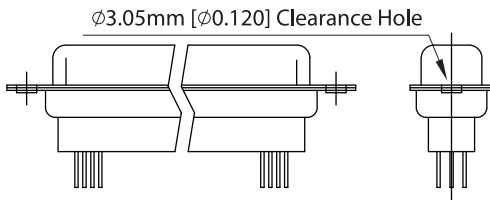

**h : 1 Front Rivet, 5.9mm[0.23]**

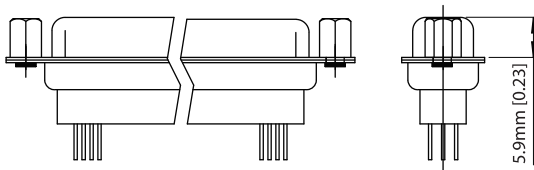

**h : 2 Rear Rivet, 5.9mm[0.23]**

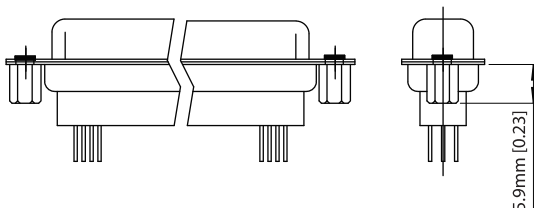

**h : 4 Standoff+2 Prong Boardlock  $\phi$ 3.0 x 11.0Lmm [ $\phi$ 0.12X0.43]  
 FOR PIN TYPE V=5.4 mm TAIL LENGTH ONLY**

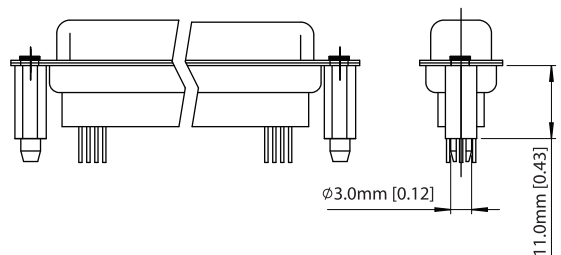

**h : 7 Standoff+2 Prong Boardlock  $\phi$ 3.2 x 9.6Lmm [ $\phi$ 0.13X0.38]  
 FOR PIN TYPE Q= 3.6mm TAIL LENGTH OR  
 U= 3.0mm TAIL LENGTH**

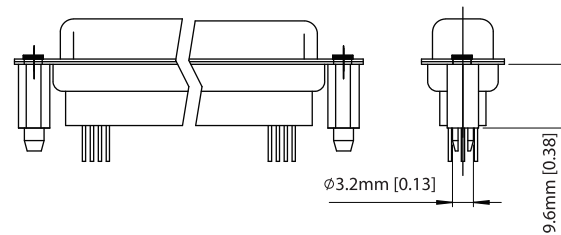

Sullins D-Subs



### D-Sub Right Angle Slim Type - 223 SERIES

## SPECIFICATIONS

### Material

- Insulator: Glass-Filled Thermoplastic PBT, UL 94V-0
- Contact: Brass
- Clinch Nut: Brass, Nickel Plated
- Boardlock: Brass, Tin Plated
- Screwlock: Steel, Nickel Plated

### Electrical

- Contact Resistance: 20m OHMs Max at 1 Amp DC.
- Insulation Resistance: 1000 MagOHMs at 500 VDC.
- Dielectric withstanding Voltage: 1000 Vac/Rms 60Hz for 1 Minute
- Current Rating: 3 Amps
- Voltage Rating: 250 Vac/Rms 60Hz
- Operating Temperature: -55°C to +105°C

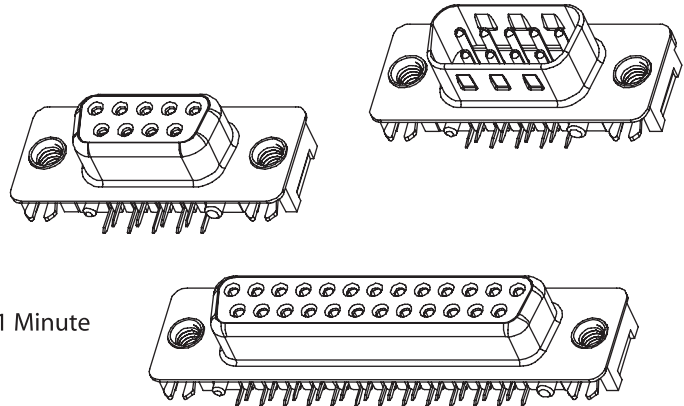

## DIMENSIONS

### 09 Positions Male

(PN EXAMPLE: SDS223-PRW2-M09-SN13-2)

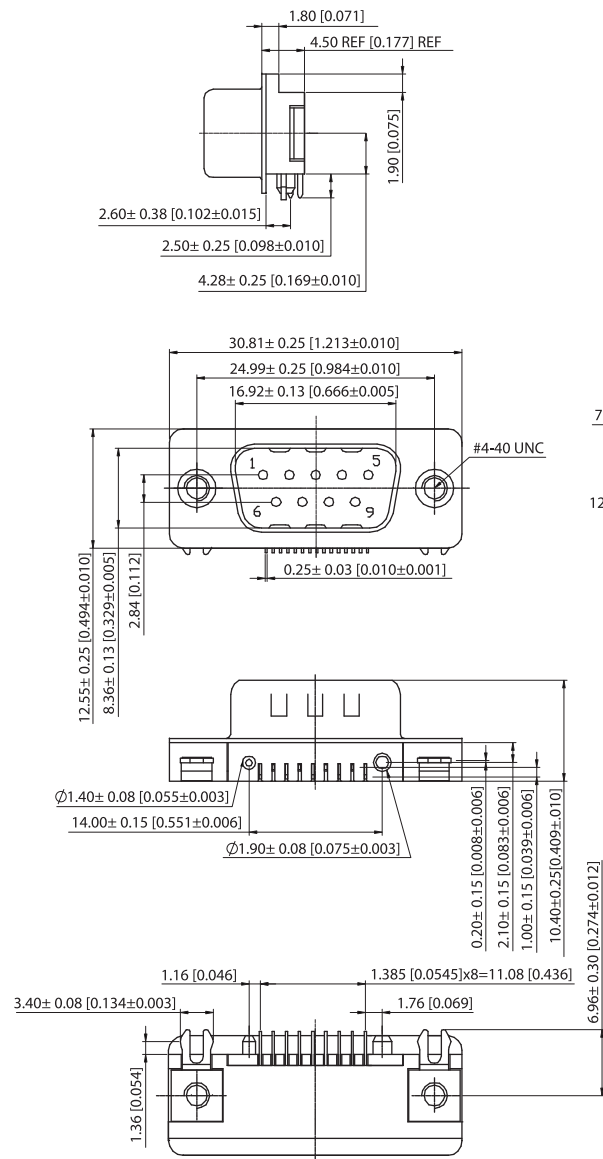

### 09 Positions Female

(PN EXAMPLE: SDS223-PRW2-F09-SN13-2)

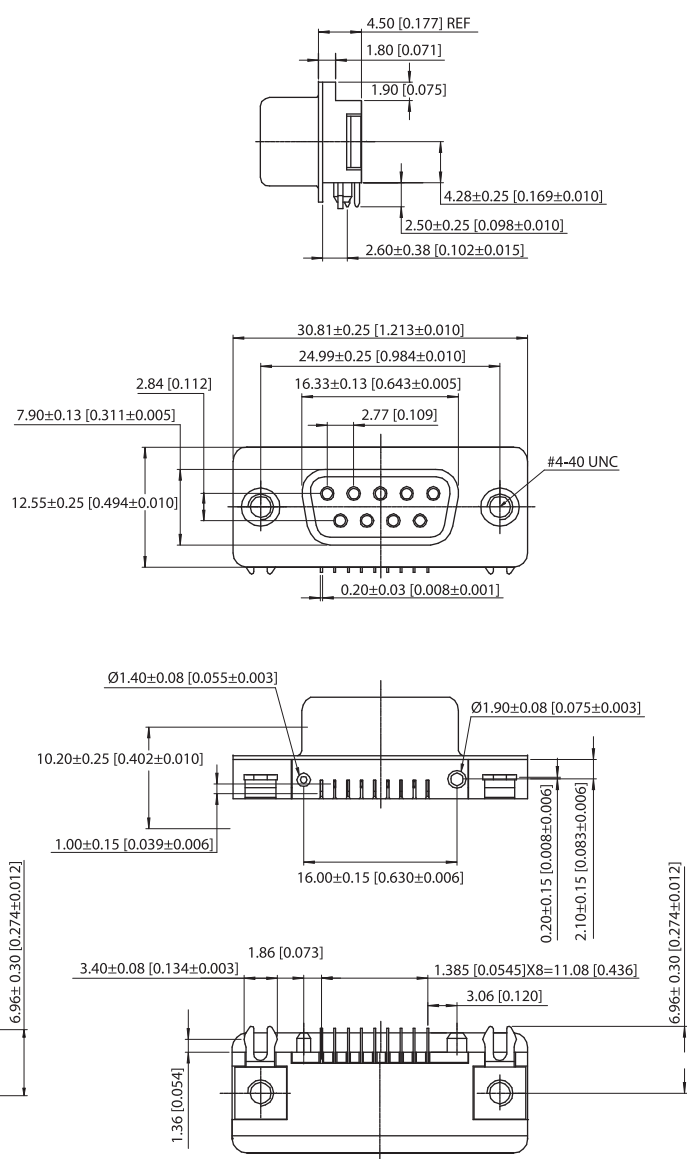

Sullins D-Subs





### D-Sub H.D. Right Angle Slim Type - 224 SERIES

## SPECIFICATIONS

### Material

- Insulator: Glass-Filled Thermoplastic PBT, UL 94V-0
- Contact: Brass
- Clinch Nut: Brass, Nickel Plated
- Boardlock: Brass, Tin Plated
- Screwlock: Steel, Nickel Plated

### Electrical

- Contact Resistance: 20m OHMs Max at 1 Amp DC.
- Insulation Resistance: 1000 MagOHMs at 500 VDC.
- Dielectric withstanding Voltage: 1000 Vac/Rms 60Hz for 1 Minute
- Current Rating: 3 Amps
- Voltage Rating: 250 Vac/Rms 60Hz
- Operating Temperature: -55°C to +105°C

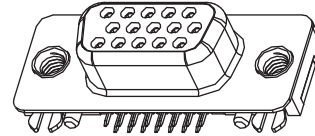
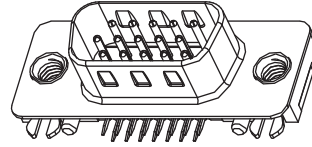

## DIMENSIONS

### 15 Positions Male

(PN EXAMPLE: SDS224-PRW2-M15-SN13-2)

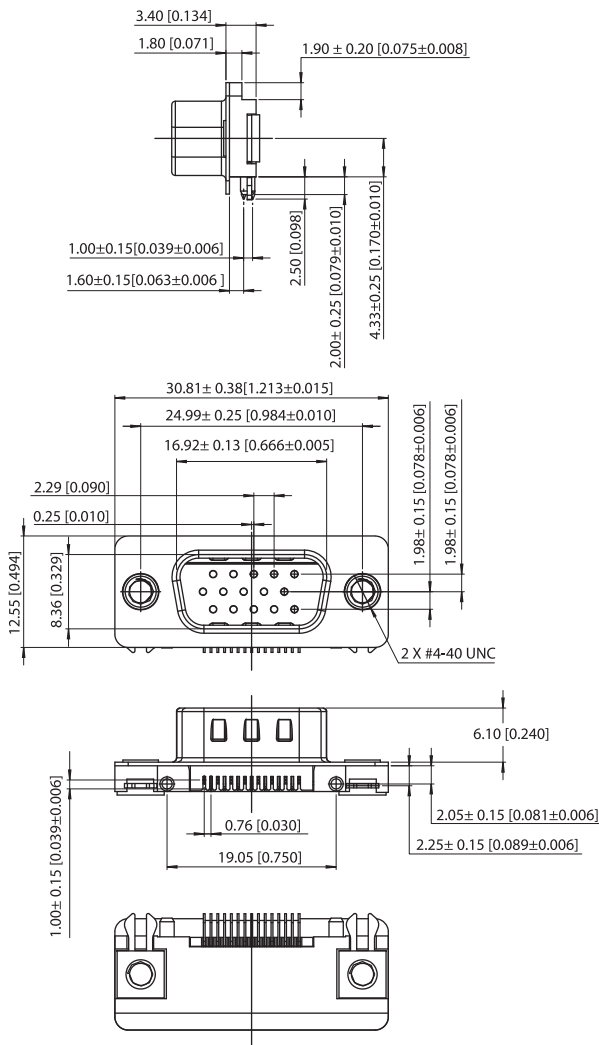

### 15 Positions Female

(PN EXAMPLE: SDS224-PRW2-F15-SN13-2)

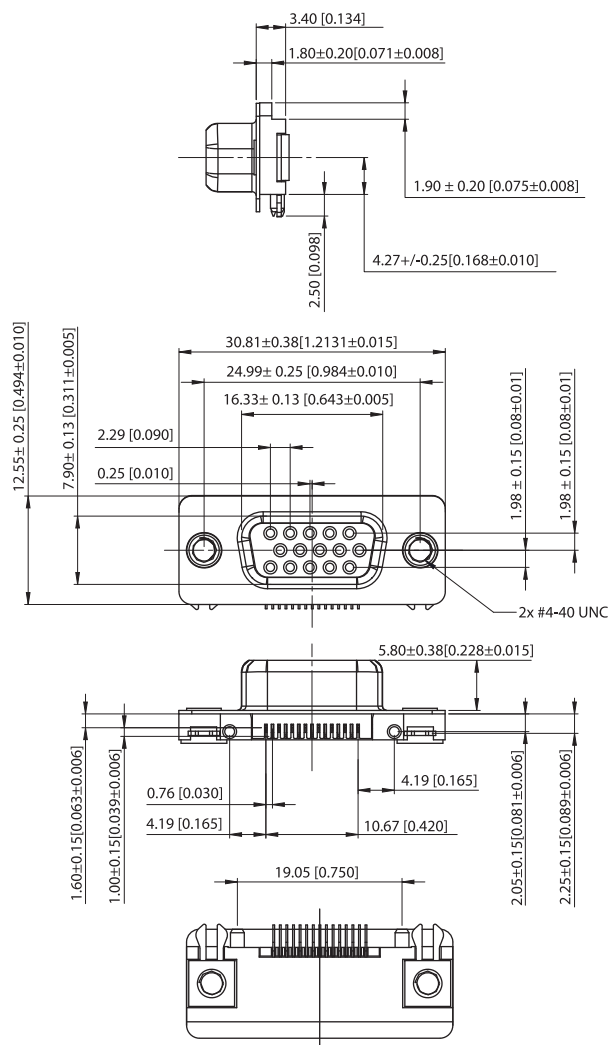

Sullins D-Subs



**D-Sub H.D. Right Angle Slim Type - 224 SERIES**

**PART NUMBER OPTIONS**

**SDS224-PRW - 15 - S N - -**  
a b c d e f g h i

**a. CONTACT PLATING**

W = .000050" Nickel Underplate  
 Gold Flash On Contact Surface,  
 .000100" Pure Tin On Termination.

**b. SHELL PLATING**

1 = Nickel  
 2 = Tin (Standard)

**c. CONTACT TYPE**

M = MALE  
 F = FEMALE

**d. NO. OF PINS**

15 = 15 POSITIONS

**e. PIN TYPE**

S = STAMPED PIN

**f. FERRITE**

N = Without Ferrite

**g. FLANGE MOUNTING OPTION**

0 =  $\phi$ 3.05mm [ $\phi$ .120] Clearance Hole  
 1 = #4-40 Female Thread  
 2 = #4-40 UNC (4.8 X 11.8mm [0.19 X 0.46])  
 Female Screwlock Installed  
 3 = #4-40 UNC (4.8 X 11.8mm [0.19 X 0.46])  
 Female Screwlock Bulk-Packed

**h. RIVET OPTIONS**

0 = NONE  
 3 = Grounding Hook Boardlock+2 Prong

**i. INSULATOR COLOR**

1 = Black  
 2 = Blue (Standard)

**RECOMMENDED PCB LAYOUT**

**15 Positions Male**

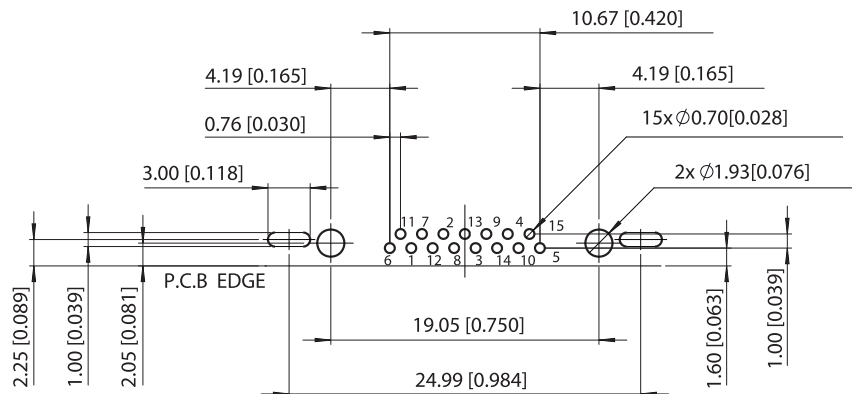

**15 Positions Female**

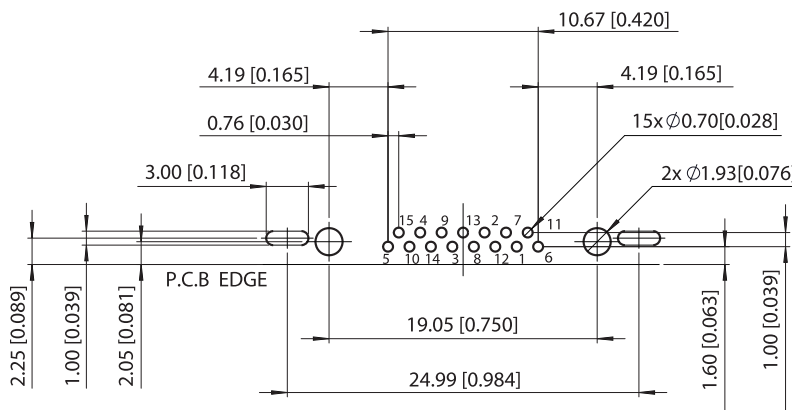

Sullins D-Subs



## GENERAL SPECIFICATIONS

### RoHS COMPLIANT



RoHS  
COMPLIANT

All parts are currently manufactured with recommended materials to meet RoHS standards. All contacts have 50u" of nickel underplating, and a large selection of plating options: Pure tin matte, overall gold, or selective gold plating. For complete part number information or operating/processing temperature parameters, visit the RoHS section of our website, or refer to page 129 of this catalog.

## MATERIALS

To determine Assembly Operating Temperature, take the lower of two temperatures

Insulator:			Operating Temperature	Processing Temperature
Standard	PBT, Valox*	Glass filled Thermoplastic Polyester	-65°C to +130°C	Wave only
Special	PPS, Ryton*	Glass/Mineral filled Polyphenylene Sulfide, Green	-650C to +220°C	260°C / 120 Seconds
Special	PPS, Ryton*	Glass filled Polyphenylene Sulfide, Brown	-650C to +200°C	260°C / 120 Seconds
Special	PA9T	High Temperature Polyamide	-650C to +150°C	260°C / 10 Seconds
Special	Peek	Glass filled Polyetheretherketone	-650C to +250°C	

### Contacts:

Standard	Phosphor Bronze (Available in All Contact Styles)	-65°C to +125°C
Special	Beryllium Copper (Consult Factory)	-65°C to +150°C
Special	Spinodal** (Consult Factory)	-65°C to +200°C
Special	Beryllium Nickel (Consult Factory)	-65°C to +300°C

### Plating:

Gold and/or Tin over .000050" Nickel Underplate, Lead Free

UL/CUL File Number: E64287 Section 2

Cage Code: 31223

\* Or equivalent.

\*\* Consult factory for special soldering guidelines.

## MECHANICAL

Board Insertion Force 16 oz Maximum per contact pair using .062"[1.58mm] thick steel test blade

Board Withdrawal Force 1 oz Minimum per contact pair using .062"[1.58mm] thick steel test blade

Special Insertion/Withdrawal forces available upon request

## ELECTRICAL PERFORMANCE (Per Mil-C-21097C)

Insulation Resistance: 5,000 Mega Ohm

<b>Contact Centers:</b>	.039[1mm]	.050[1.27mm]	.100[2.54mm]	.125[3.18mm]	.150[3.81mm]	.156[3.96mm]
<b>Operating Voltage:</b>	225 VAC	300 VAC	700 VAC	750 VAC	850 VAC	950 VAC
<b>DWV:</b>	675 VAC	900 VAC	2100 VAC	2250 VAC	2550 VAC	2550 VAC

**Current Rating:** 1 to 5 amp per contact

**Contact Resistance:** 30 milli ohm maximum at rated current

### Registered Trademarks

Sabic Innovative Plastics:	Valox	Phillips 66: Ryton	RTP Compounder: PEEK	Sullins Electronics: Sullins
Gardner-Denver Co.:	Wire Wrap	Ametek: Spinodal	Underwriters Labs: UL	Sullins Electronics: Zero Lead Time



**MP - 0 100 - 22 - D W - 5 xxx**

**PLATING - RoHS Compliant**

ALL PLATINGS ARE LEAD FREE AND HAVE  
.000050" NICKEL UNDERPLATE

Contact Surface	Termination
*MPSL = .000010" Gold	.000100" Pure Tin Matte
*EMPSL = .000010" Gold	.000100" Pure Tin Matte
*MPL = .000100" Overall Pure Tin, Matte	
*EMPL = .000100" Overall Pure Tin, Matte	
MP = .000010" Overall Gold	
EMP = .000010" Overall Gold	
MPP = Spinodal Contact Material (Overall Gold Only)	
EMPP = Spinodal Contact Material (Overall Gold Only)	

**\*Tin Requires 'K' Modification Code**  
Use 'E' code for Economy Eyelet Only  
See Modification codes for alternate plating

**INSULATOR MATERIAL**

All Materials are U.L. Approved 94V-0

- 0 = PBT, Blue
- 1 = PPS, Brown
- 2 = PBT, Green
- 3 = PBT, Black
- 4 = PA9T, Black
- 5 = PPS, Black
- 6 = PPS, Green
- 7 = PPS, Brown
- 8 = Peek, Natural

**CONTACT CENTERS**

- 100 = .100" [2.54mm]
- 125 = .125" [3.18mm]
- 150 = .150" [3.84mm]
- 156 = .156" [3.96mm]

**NUMBER OF POSITIONS**

02 - 70 Contacts Per Row

**READOUT**

D = Dual Row

**TERMINATION TYPE**

- FS = .045" Square Tails  
.720" Insulator Height
- P = Solder Eyelet  
.431" Insulator Height
- PE = Economy Eyelet, .156" Pitch only  
.431" Insulator Height, Card Extender
- R = .025" Round Tails  
.610" Insulator Height
- S = Dip Solder - .431" Insulator Height
- SE = Card Extender - .431" Insulator Height
- W = .025" Square Wire Wrap  
.610" Insulator Height
- WE = .025" Square Card Extender  
.610" Insulator Height

**MOUNTING STYLE**

- 1 = **.125" Clearance Holes**  
.245" Ears, .431" Insulator  
.250" Flush Ears, .610" Insulator
- 2 = **#4-40 Threaded Insert**  
.245" Ears, .431" Insulator  
.250" Flush Ears, .610" Insulator
- 3 = **Floating Bobbin**  
.220" Ears not Including Bobbin (Flush Ears on .610 Insulator)
- 4 = **No Mounting Ears**  
All Connectors
- 5 = **Raised with .125" Clearance Holes**  
Wire Wrap/Thru Hole, Only available in .610" Insulator
- 6 = **Raised with #4-40 Threaded Insert**  
Wire Wrap/Thru Hole, Only available in .610" Insulator
- 8 = **.125" Side Holes** (Cross Drilled)
- 9 = **One Ear, .125" Clearance Hole**  
.431" Insulator, Dip Solder & Eyelet
- 10 = **One Ear, #4-40 Threaded Insert**  
.431" Insulator, Dip Solder & Eyelet
- 11 = **.142" Mounting Holes**  
.431" Insulator, Dip Solder, Eyelet  
.610" Insulator, .025" Sq & Round
- 12 = **.128" Clearance Holes**  
.431" Insulator, Dip Solder & Eyelet  
.610" Insulator, .025" Sq & Round
- 13 = **Flush Ears, .128" Clearance Holes**  
.430" Ears with Pad on .610" Insulator Height, Wire Wrap Only
- 14 = **.142" Side Holes** (Cross Drilled)  
.431" Insulator, Dip Solder & Eyelet  
.610" Insulator, .025" Sq & Round
- 15 = **Flush Ears, .125" Clearance Holes**  
.190" Ears, No Pad  
.610" Insulator, .025" Sq & Round
- 16 = **Flush .250" Ears to top of the Card Entry Side of the Connector,**  
.610" Insulator, .025" Sq & Round
- 18 = **Flush Ears, .125" Side Holes** (Cross Drilled)
- 19 = **.152" Clearance Holes**  
.610" Insulator, .025" Sq & Round
- 58 = **Raised Ears, .125" Side Holes** (Cross Drilled)
- 81 = **Flush Ears, .125" Side Holes**  
.250" Ears with Pad,  
.610" Insulator, .025" Sq & Round
- 86 = **Side Holes with #4-40 Threaded Insert**  
.250" Ears with Pad,  
.610" Insulator, .025" Sq & Round

**MODIFICATION CODE**

CONSULT FACTORY FOR OTHER OPTIONS

- A = **Contacts Loaded one side only**
- B = **Center Barrier for 28/56 - .156" Dip Solder & Eyelet**
- C = **.030" Longer Cardslot and Mounting Hole Centers for 22/44, All .156" (Consult Factory)**
- D = **.000050" Gold Plating - (Consult Factory)**
- E9 = **.200" Row Spacing on .156" Contact Centers**
- F = **6.802" Cardslot for 43/86 .156" Eyelet & Wire Wrap Only**
- F9 = **6.802" Cardslot and .200" Row Spacing for 43/86 Dip Solder Only**
- G = **.000030" Gold Plating on Contact Surface; .000010" Gold Overall**
- H = **.190" Contact Length for .025" Square & .026" Round Contacts .250" Contact Length without Standoffs**
- J = **Low Insertion Force**
- K = **MPSL - Selective Gold with Pure Tin, Matte Plating on Tails**  
**MPL - Overall Pure Tin, Matte**
- L = **.140" Contact Length for .156" Dip Solder Only**
- M = **Pad on Bottom of Mounting Ears for .156", .431" Insulator Height, Dip Solder & Eyelet Only**
- N = **Hi-light Contact ID on Bottom (Consult Factory)**
- P = **Engraving Reversed (Consult Factory)**
- Q = **Right Angle Connector Contacts Untrimmed (Requires 'R' Modification Code)**
- R = **Right Angle Connectors**
- S = **Shorter Overall Length**
- T = **Center Standoffs Removed .100" & .125" Wire Wrap Only**
- TT = **No Standoffs**
- U = **.000020" Gold Plating**
- X9 = **.200" Row Spacing for .100" & .156" Dip Solder Only .250" Row Spacing for .125" Dip Solder Only**
- Y = **Beryllium Copper Contacts**
- Z = **Standoffs on .156" Wire Wrap**

**See applicable specification pages for more information.**

Specifications are subject to change without notice.



**.100" [2.54 mm] Contact Centers, .431" [10.95 mm] Insulator Height,  
Dip Solder**

**SPECIFICATIONS**

- Accommodates .062" ± .008" [1.57 ± 0.20] PC Board
- Insulator Material available in PBT, PPS or PA9T
- 3 Amp Current Rating
- Insulator / Contact Specifications and Part Number Options See opposite page
- Row Spacing Available in .140" or .200" (Use Modification Code 'X9' for .200")
- P/N 04-0003-000 for In Between Contact Polarizing Key See Page 204 (Sold Separately)
- Molded-in Key Available - Consult Factory

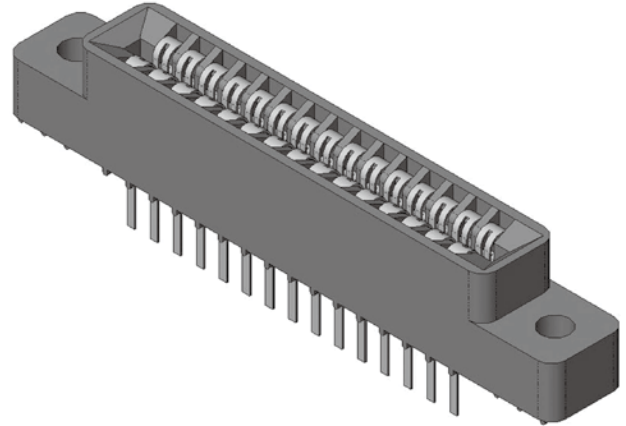

**TERMINATION TYPE**

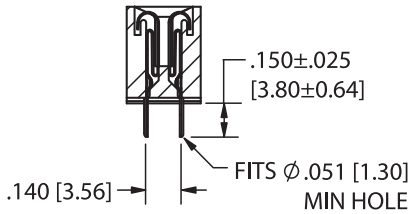

**DIP SOLDER (S)  
.140" ROW SPACING**

*Example P/N: MP~~S~~L-0100-10-D~~S~~-1K*

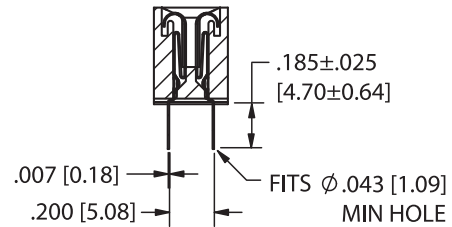

**DIP SOLDER (S)  
.200" ROW SPACING  
USE 'X9' MODIFICATION CODE**

*Example P/N: MP~~S~~L-0100-10-D~~S~~-1X9K*

**MOUNTING STYLE**

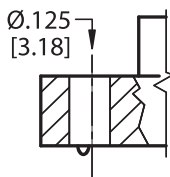

**(STYLE 1)**

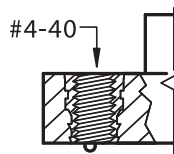

**(STYLE 2)**



**(STYLE 3)**



**(STYLE 4)**



**.100" [2.54 mm] Contact Centers, .431" [10.95 mm] Insulator Height, Dip Solder**

**PART NUMBER OPTIONS**

**MPSL - 0 100 - 10 - D S - 1 K**

**PLATING - RoHS Compliant**

All Platings are Lead Free and have .000050" Nickel Underplate

**Contact Surface Termination**

\*MPSL = .000010" Gold .000100" Pure Tin, Matte

\*MPL = .000100" Overall Pure Tin, Matte

MP = .000010" Overall Gold

\*Requires 'K' Modification Code

**INSULATOR MATERIAL\*\***

0 = PBT

**CONTACT CENTERS**

100 = .100" [2.54mm]

**NUMBER OF POSITIONS**

Contacts Per Row (See Position Chart Below)

**MODIFICATION CODE\*\***

K = Required on MPSL or MPL Plating  
Omit for MP Plating (Overall Gold)  
X9 = .200" Row Spacing

**MOUNTING STYLE (See Opposite Page)**

- 1 = .125" Clearance Hole
- 2 = #4-40 Threaded Insert
- 3 = Floating Bobbin
- 4 = No Mounting

**TERMINATION TYPE (See Opposite Page)**

S = Dip Solder

**READOUT**

D = Dual

\*\* See Pages 160-161 for Specifications and other Variations

**DIMENSIONS**

Dimensions in [ ] are in millimeters, all others are in inches.

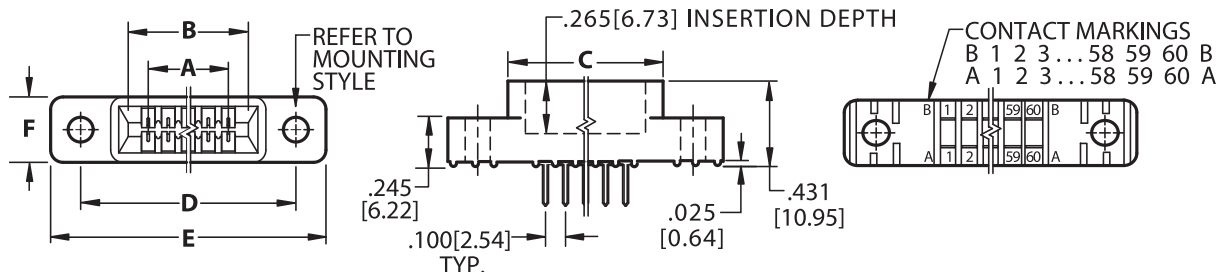

POSITIONS/ CONTACTS	INCHES						[MILLIMETERS]						
	A±.008	B±.008	C±.015	D±.010	E±.020	F±.005	A±0.20	B±0.20	C±0.38	D±0.25	E±0.51	F±0.13	
05/10	0.400	0.600	0.775	1.075	1.375	0.330	10.16	15.24	19.69	27.31	34.93	8.38	
06/12	0.500	0.700	0.875	1.175	1.475		12.70	17.78	22.23	29.85	37.47		
07/14	0.600	0.800	0.975	1.275	1.575		15.24	20.32	24.77	32.39	40.01		
08/16	0.700	0.900	1.075	1.375	1.675		17.78	22.86	27.31	34.93	42.55		
10/20	0.900	1.100	1.275	1.575	1.875		22.86	27.94	32.39	40.01	47.63		
12/24	1.100	1.300	1.475	1.775	2.075		27.94	33.02	37.47	45.09	52.71		
13/26	1.200	1.400	1.575	1.875	2.175		30.48	35.56	40.01	47.63	55.25		
15/30	1.400	1.600	1.775	2.075	2.375		35.56	40.64	45.09	52.71	60.33		
17/34	1.600	1.800	1.975	2.275	2.575		40.64	45.72	50.17	57.79	65.41		
18/36	1.700	1.900	2.075	2.375	2.675		43.18	48.26	52.71	60.33	67.95		
19/38	1.800	2.000	2.175	2.475	2.775		45.72	50.80	55.25	62.87	70.49		
20/40	1.900	2.100	2.275	2.575	2.875		48.26	53.34	57.79	65.41	73.03		
22/44	2.100	2.300	2.475	2.775	3.075		53.34	58.42	62.87	70.49	78.11		
25/50	2.400	2.600	2.775	3.075	3.375		60.96	66.04	70.49	78.11	85.73		
26/52	2.500	2.700	2.875	3.175	3.475		63.50	68.58	73.03	80.65	88.27		
28/56	2.700	2.900	3.075	3.375	3.675		68.58	73.66	78.11	85.73	93.35		
30/60	2.900	3.100	3.275	3.575	3.875	73.66	78.74	83.19	90.81	98.43			
31/62	3.000	3.200	3.375	3.675	3.975	76.20	81.28	85.73	93.35	100.97			
35/70	3.400	3.600	3.775	4.075	4.375	86.36	91.44	95.89	103.51	111.13			
36/72	3.500	3.700	3.875	4.175	4.475	88.90	93.98	98.43	106.05	113.67			
40/80	3.900	4.100	4.275	4.575	4.875	99.06	104.14	108.59	116.21	123.83			
43/86	4.200	4.400	4.575	4.875	5.175	106.68	111.76	116.21	123.83	131.45			
44/88	4.300	4.500	4.675	4.975	5.275	109.22	114.30	118.75	126.37	133.99			
49/98	4.800	5.000	5.175	5.475	5.775	121.92	127.00	131.45	139.07	146.69			
50/100	4.900	5.100	5.275	5.575	5.875	124.46	129.54	133.99	141.61	149.23			
60/120	5.900	6.100	6.275	6.575	6.875	149.86	154.94	159.39	167.01	174.63			
65/130	6.400	6.600	6.775	7.075	7.375	162.56	167.64	172.09	179.71	187.33			



**.100" [2.54 mm] Contact Centers, .431" [10.95 mm] Insulator Height,  
Card Extender**

**SPECIFICATIONS**

- Accommodates .062" ± .008" [1.57 ± 0.20] PC Board
- Insulator Material available in PBT, PPS or PA9T
- 3 Amp Current Rating
- Insulator / Contact Specifications and Part Number Options See opposite page
- P/N 04-0003-000 for In Between Contact Polarizing Key See Page 204 (Sold Separately)
- Molded-in Key Available - Consult Factory

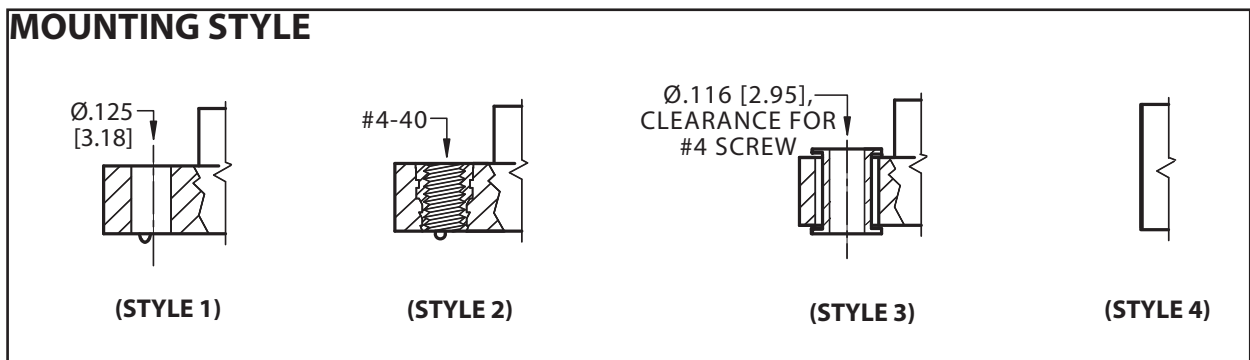
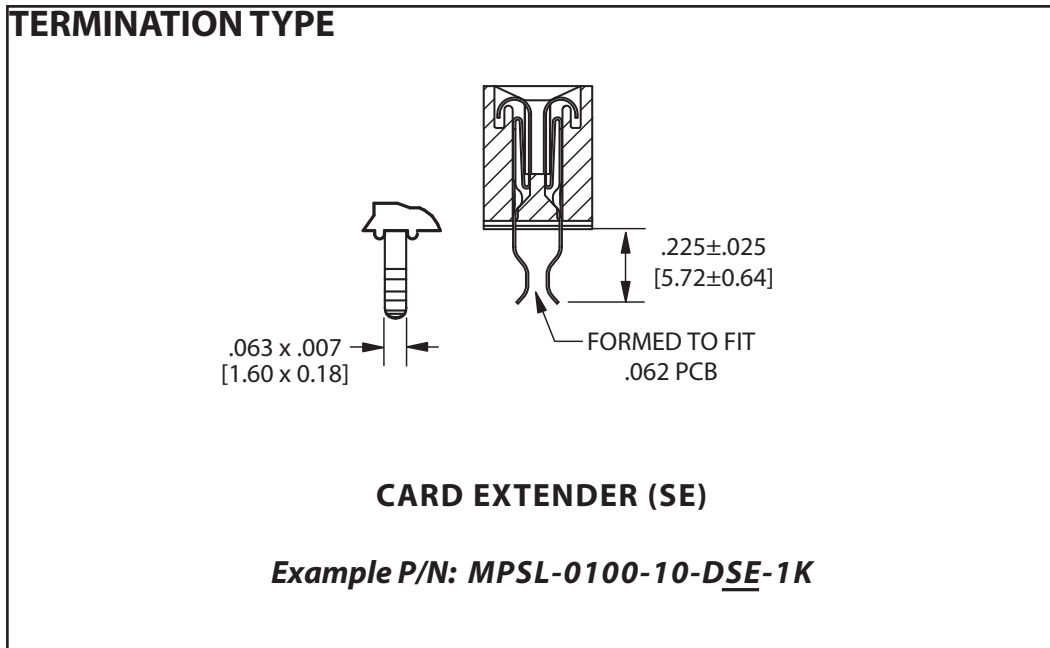
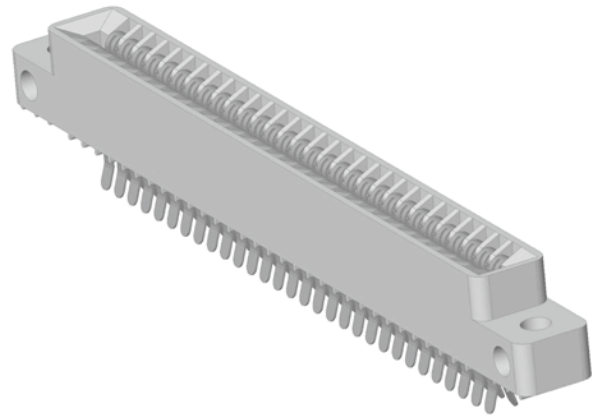

Micro Plastics



**.100" [2.54 mm] Contact Centers, .431" [10.95 mm] Insulator Height, Card Extender**

**PART NUMBER OPTIONS**

**MPSL - 0 100 - 10 - D SE - 1 K**

**PLATING - RoHS Compliant**

All Platings are Lead Free and have .000050" Nickel Underplate

**Contact Surface Termination**

- \*MPSL = .000010" Gold .000100" Pure Tin Matte
- \*MPL = .000100" Overall Pure Tin, Matte
- MP = .000010" Overall Gold

**\* Requires 'K' Modification Code**

Other Plating and thicknesses available upon request

**INSULATOR MATERIAL\*\***

0 = PBT

**CONTACT CENTERS**

100 = .100" [2.54mm]

**NUMBER OF POSITIONS**

Contacts Per Row (See Position Chart Below)

**PLATING MODIFICATION CODE\*\***

K = Required on Tin Plating  
Omit for MP Plating (Overall Gold)

**MOUNTING STYLE** (See Opposite Page)

- 1 = .125" Clearance Hole
- 2 = #4-40 Threaded Insert
- 3 = Floating Bobbin
- 4 = No Mounting

**TERMINATION TYPE** (See Opposite Page)

SE = Card Extender

**READOUT**

D = Dual

**\*\* See Pages 160-161 for Specifications and other Variations**

**DIMENSIONS**

Dimensions in [ ] are in millimeters, all others are in inches.

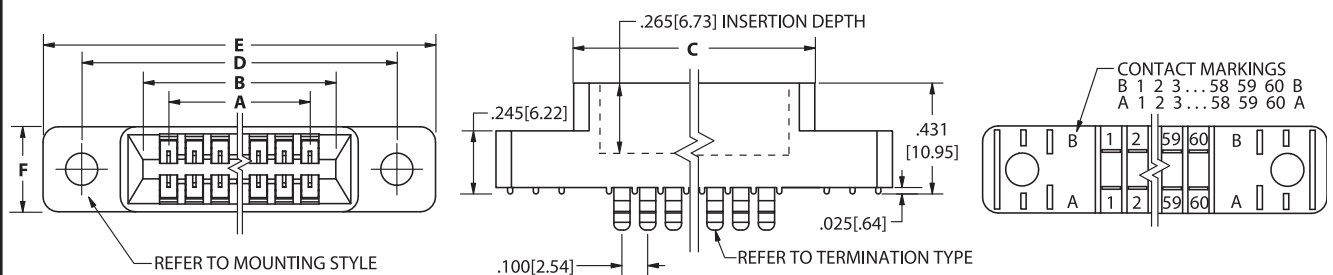

POSITIONS/ CONTACTS	INCHES						[MILLIMETERS]					
	A±.008	B±.008	C±.015	D±.010	E±.020	F±.005	A±0.20	B±0.20	C±0.38	D±0.25	E±0.51	F±0.13
05/10	0.400	0.600	0.775	1.075	1.375	0.330	10.16	15.24	19.69	27.31	34.93	8.38
06/12	0.500	0.700	0.875	1.175	1.475		12.70	17.78	22.23	29.85	37.47	
07/14	0.600	0.800	0.975	1.275	1.575		15.24	20.32	24.77	32.39	40.01	
08/16	0.700	0.900	1.075	1.375	1.675		17.78	22.86	27.31	34.93	42.55	
10/20	0.900	1.100	1.275	1.575	1.875		22.86	27.94	32.39	40.01	47.63	
12/24	1.100	1.300	1.475	1.775	2.075		27.94	33.02	37.47	45.09	52.71	
13/26	1.200	1.400	1.575	1.875	2.175		30.48	35.56	40.01	47.63	55.25	
15/30	1.400	1.600	1.775	2.075	2.375		35.56	40.64	45.09	52.71	60.33	
17/34	1.600	1.800	1.975	2.275	2.575		40.64	45.72	50.17	57.79	65.41	
18/36	1.700	1.900	2.075	2.375	2.675		43.18	48.26	52.71	60.33	67.95	
19/38	1.800	2.000	2.175	2.475	2.775		45.72	50.80	55.25	62.87	70.49	
20/40	1.900	2.100	2.275	2.575	2.875		48.26	53.34	57.79	65.41	73.03	
22/44	2.100	2.300	2.475	2.775	3.075		53.34	58.42	62.87	70.49	78.11	
25/50	2.400	2.600	2.775	3.075	3.375		60.96	66.04	70.49	78.11	85.73	
26/52	2.500	2.700	2.875	3.175	3.475		63.50	68.58	73.03	80.65	88.27	
28/56	2.700	2.900	3.075	3.375	3.675		68.58	73.66	78.11	85.73	93.35	
30/60	2.900	3.100	3.275	3.575	3.875	73.66	78.74	83.19	90.81	98.43		
31/62	3.000	3.200	3.375	3.675	3.975	76.20	81.28	85.73	93.35	100.97		
35/70	3.400	3.600	3.775	4.075	4.375	86.36	91.44	95.89	103.51	111.13		
36/72	3.500	3.700	3.875	4.175	4.475	88.90	93.98	98.43	106.05	113.67		
40/80	3.900	4.100	4.275	4.575	4.875	99.06	104.14	108.59	116.21	123.83		
43/86	4.200	4.400	4.575	4.875	5.175	106.68	111.76	116.21	123.83	131.45		
44/88	4.300	4.500	4.675	4.975	5.275	109.22	114.30	118.75	126.37	133.99		
49/98	4.800	5.000	5.175	5.475	5.775	121.92	127.00	131.45	139.07	146.69		
50/100	4.900	5.100	5.275	5.575	5.875	124.46	129.54	133.99	141.61	149.23		
60/120	5.900	6.100	6.275	6.575	6.875	149.86	154.94	159.39	167.01	174.63		
65/130	6.400	6.600	6.775	7.075	7.375	162.56	167.64	172.09	179.71	187.33		



**.100" [2.54 mm] Contact Centers, .431" [10.95 mm] Insulator Height, Eyelet**

**SPECIFICATIONS**

- Accommodates .062" ± .008" [1.57 ± 0.20] PC Board
- Insulator Material available in PBT, PPS or PA9T
- 3 Amp Current Rating
- Insulator / Contact Specifications and Part Number Coding See opposite page
- P/N 04-0003-000 for In Between Contact Polarizing Key See Page 204 (Sold Separately)
- Molded-in Key Available - Consult Factory

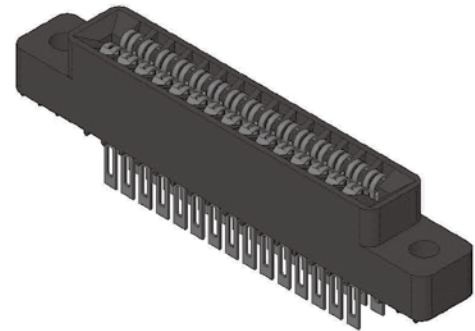

**TERMINATION TYPE**

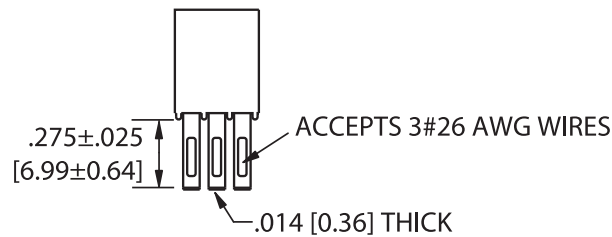

**EYELET (P)**

**Example P/N: MP-0100-10-DP-1**

**MOUNTING STYLE**

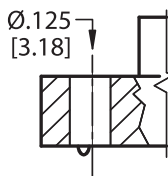

(STYLE 1)

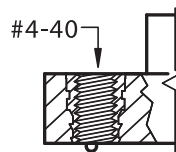

(STYLE 2)

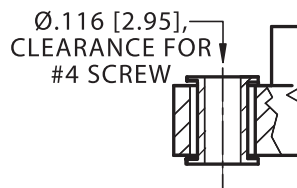

(STYLE 3)



(STYLE 4)



**.100" [2.54 mm] Contact Centers, .431" [10.95 mm] Insulator Height, Eyelet**

**PART NUMBER OPTIONS**

**MPL - 0 100 - 10 - D P - 1 K**

**PLATING - RoHS Compliant**

All Platings are Lead Free and have .000050" Nickel Underplate

\*MPL = .000100" Overall Pure Tin, Matte

MP = .000010" Overall Gold

\* Requires 'K' Modification Code

Other Plating and thicknesses available upon request

**INSULATOR MATERIAL\*\***

0 = PBT

**CONTACT CENTERS**

100 = .100" [2.54mm]

**NUMBER OF POSITIONS**

Contacts Per Row (See Position Chart Below)

**PLATING MODIFICATION CODE\*\***

K = Required on Tin Plating  
Omit for MP Plating (Overall Gold)

**MOUNTING STYLE (See Opposite Page)**

- 1 = .125" Clearance Hole
- 2 = #4-40 Threaded Insert
- 3 = Floating Bobbin
- 4 = No Mounting

**TERMINATION TYPE (See Opposite Page)**

P = Pierced Eyelet, .014" Thick

**READOUT**

D = Dual

**\*\* See Pages 160-161 for Specifications and other Variations**

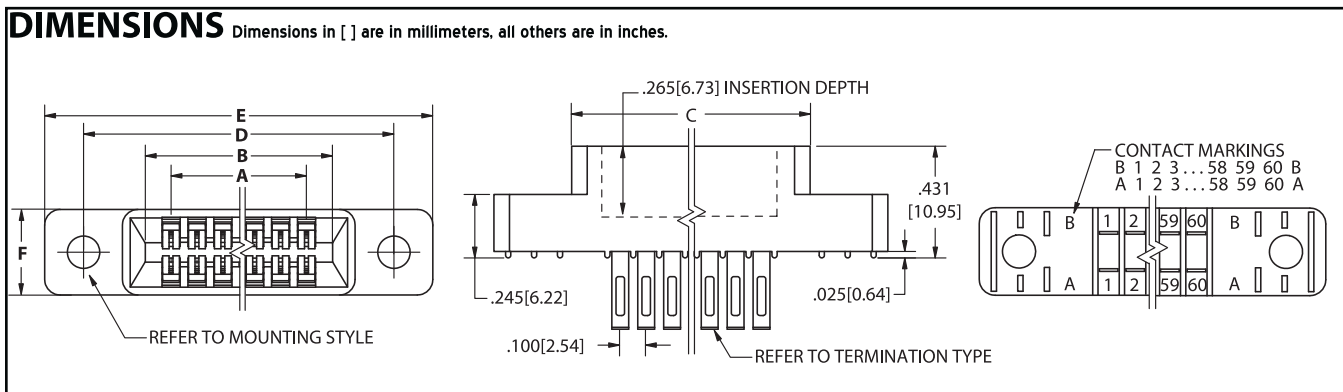

POSITIONS/ CONTACTS	INCHES						[MILLIMETERS]					
	A±.008	B±.008	C±.015	D±.010	E±.020	F±.005	A±0.20	B±0.20	C±0.38	D±0.25	E±0.51	F±0.13
05/10	0.400	0.600	0.775	1.075	1.375	0.330	10.16	15.24	19.69	27.31	34.93	8.38
06/12	0.500	0.700	0.875	1.175	1.475		12.70	17.78	22.23	29.85	37.47	
07/14	0.600	0.800	0.975	1.275	1.575		15.24	20.32	24.77	32.39	40.01	
08/16	0.700	0.900	1.075	1.375	1.675		17.78	22.86	27.31	34.93	42.55	
10/20	0.900	1.100	1.275	1.575	1.875		22.86	27.94	32.39	40.01	47.63	
12/24	1.100	1.300	1.475	1.775	2.075		27.94	33.02	37.47	45.09	52.71	
13/26	1.200	1.400	1.575	1.875	2.175		30.48	35.56	40.01	47.63	55.25	
15/30	1.400	1.600	1.775	2.075	2.375		35.56	40.64	45.09	52.71	60.33	
17/34	1.600	1.800	1.975	2.275	2.575		40.64	45.72	50.17	57.79	65.41	
18/36	1.700	1.900	2.075	2.375	2.675		43.18	48.26	52.71	60.33	67.95	
19/38	1.800	2.000	2.175	2.475	2.775		45.72	50.80	55.25	62.87	70.49	
20/40	1.900	2.100	2.275	2.575	2.875		48.26	53.34	57.79	65.41	73.03	
22/44	2.100	2.300	2.475	2.775	3.075		53.34	58.42	62.87	70.49	78.11	
25/50	2.400	2.600	2.775	3.075	3.375		60.96	66.04	70.49	78.11	85.73	
26/52	2.500	2.700	2.875	3.175	3.475		63.50	68.58	73.03	80.65	88.27	
28/56	2.700	2.900	3.075	3.375	3.675		68.58	73.66	78.11	85.73	93.35	
30/60	2.900	3.100	3.275	3.575	3.875		73.66	78.74	83.19	90.81	98.43	
31/62	3.000	3.200	3.375	3.675	3.975	76.20	81.28	85.73	93.35	100.97		
35/70	3.400	3.600	3.775	4.075	4.375	86.36	91.44	95.89	103.51	111.13		
36/72	3.500	3.700	3.875	4.175	4.475	88.90	93.98	98.43	106.05	113.67		
40/80	3.900	4.100	4.275	4.575	4.875	99.06	104.14	108.59	116.21	123.83		
43/86	4.200	4.400	4.575	4.875	5.175	106.68	111.76	116.21	123.83	131.45		
44/88	4.300	4.500	4.675	4.975	5.275	109.22	114.30	118.75	126.37	133.99		
49/98	4.800	5.000	5.175	5.475	5.775	121.92	127.00	131.45	139.07	146.69		
50/100	4.900	5.100	5.275	5.575	5.875	124.46	129.54	133.99	141.61	149.23		
60/120	5.900	6.100	6.275	6.575	6.875	149.86	154.94	159.39	167.01	174.63		
65/130	6.400	6.600	6.775	7.075	7.375	162.56	167.64	172.09	179.71	187.33		

Micro Plastics



**.100" [2.54 mm] Contact Centers, .610" [15.49 mm] Insulator Height,  
Wire Wrap & Dip Solder**

**SPECIFICATIONS**

- Accommodates .062" ± .008" [1.57 ± 0.20] PC Board
- Insulator Material available in PBT, PPS or PA9T
- 3 Amp Current Rating
- Insulator / Contact Specifications and Part Number Coding See opposite page
- P/N 04-0004-000 for In Between Contact Polarizing Key See Page 204 (Sold Separately)
- Molded-in Key Available - Consult Factory

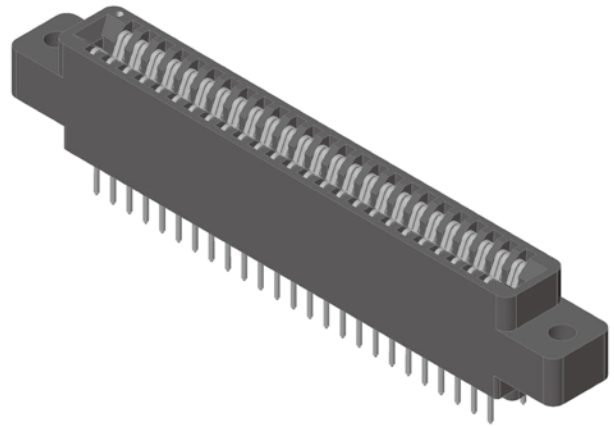

**TERMINATION TYPE**

**LOOP BELLOWS**

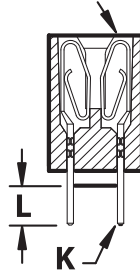

**LOOP BELLOWS**

TERMINATION CODE	MODIFICATION CODE	TYPE	POST CROSS SECTION K	POST LENGTH L	FITS MIN. HOLE SIZE	EXAMPLE PART NUMBER
R	H	Dip Solder	.025 [0.64] Round	.190 [4.83]	.033 [0.84]	<i><b>MPSL-0100-10-DR-1HK</b></i>
R	H(.165)	Dip Solder	.025 [0.64] Round	.165 [4.19]	.033 [0.84]	<i><b>MPSL-0100-10-DR-1HK(.165)</b></i>
W	H	Dip Solder	.025 [0.64] Square	.190 [4.83]	.040 [1.02]	<i><b>MPSL-0100-10-DW-1HK</b></i>
W	OMIT	Wire Wrap	.025 [0.64] Square	.560 [14.20]	.040 [1.02]	<i><b>MPSL-0100-10-DW-1K</b></i>

**MOUNTING STYLE**

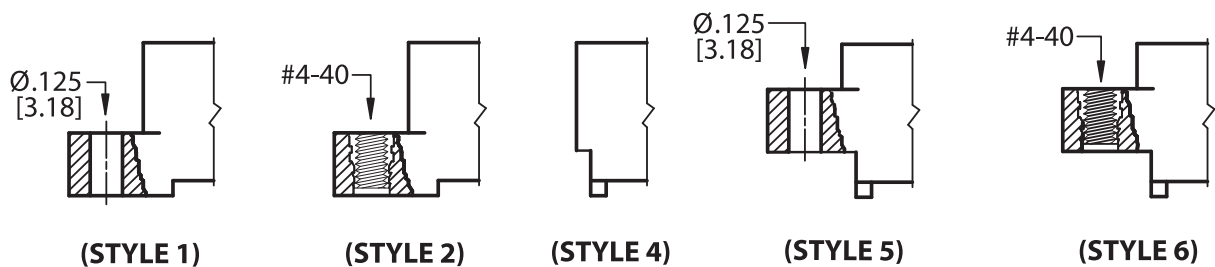

Micro Plastics

**.100" [2.54 mm] Contact Centers, .610" [15.49 mm] Insulator Height,  
Wire Wrap & Dip Solder**



**PART NUMBER OPTIONS**

**MPSL - 0 100 - 10 - D W - 1 H K**

**PLATING - RoHS Compliant**

All Platings are Lead Free and have .000050" Nickel Underplate

**Contact Surface Termination**

- \*MPSL = .000010" Gold .000100" Pure Tin, Matte
- \*MPL = .000100" Overall Pure Tin, Matte
- MP = .000010" Overall Gold

**\*Requires 'K' Modification Code**

**INSULATOR MATERIAL\*\***

0 = PBT

**CONTACT CENTERS**

100 = .100" [2.54mm]

**NUMBER OF POSITIONS**

Contacts Per Row (See Position Chart Below)

**READOUT**

D = Dual

**PLATING MODIFICATION CODE\*\***

K = Required on MPSL or MPL Plating  
Omit for MP Plating (Overall Gold)

**MODIFICATION CODE\*\***

(See Opposite Page)

H = Dip Solder .190[4.83] Tail Length  
(.025 Round or .025 Square)

H(.165) = Dip Solder .165[4.19] Tail Length  
(.025 Round Only)

**MOUNTING STYLE** (See Opposite Page)

- 1 = .125" Clearance Hole
- 2 = #4-40 Threaded Insert
- 4 = No Mounting
- 5 = Raised, .125" Clearance Hole
- 6 = Raised, #4-40 Threaded Insert

**TERMINATION TYPE** (See Opposite Page)

**LOOP BELLOWS**

- R = .025[.64mm] Round
- W = .025[.64mm] Square

**\*\* See Pages 160-161 for Specifications and other Variations**

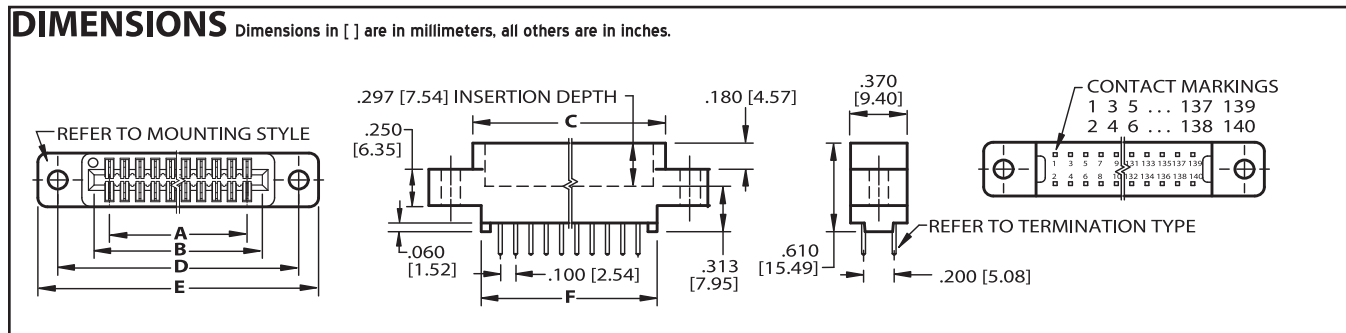

POSITIONS/ CONTACTS	INCHES						[MILLIMETERS]					
	A±.008	B±.008	C±.015	D±.010	E±.020	F±.015	A±0.20	B±0.20	C±0.38	D±0.25	E±0.51	F±0.38
06/12	0.500	0.700	0.860	1.175	1.435	0.750	12.70	17.78	21.84	29.85	36.45	19.05
08/16	0.700	0.900	1.060	1.375	1.635	0.950	17.78	22.86	26.92	34.93	41.53	24.13
10/20	0.900	1.100	1.260	1.575	1.835	1.150	22.86	27.94	32.00	40.01	46.61	29.21
12/24	1.100	1.300	1.460	1.775	2.035	1.350	27.94	33.02	37.08	45.09	51.69	34.29
13/26	1.200	1.400	1.560	1.875	2.135	1.450	30.48	35.56	39.62	47.63	54.23	36.83
15/30	1.400	1.600	1.760	2.075	2.335	1.650	35.56	40.64	44.70	52.71	59.31	41.91
17/34	1.600	1.800	1.960	2.275	2.535	1.850	40.64	45.72	49.78	57.79	64.39	46.99
18/36	1.700	1.900	2.060	2.375	2.635	1.950	43.18	48.26	52.32	60.33	66.93	49.53
20/40	1.900	2.100	2.260	2.575	2.835	2.150	48.26	53.34	57.40	65.41	72.01	54.61
22/44	2.100	2.300	2.460	2.775	3.035	2.350	53.34	58.42	62.48	70.49	77.09	59.69
24/48	2.300	2.500	2.660	2.975	3.235	2.550	58.42	63.50	67.56	75.57	82.17	64.77
25/50	2.400	2.600	2.760	3.075	3.335	2.650	60.96	66.04	70.10	78.11	84.71	67.31
28/56	2.700	2.900	3.060	3.375	3.635	2.950	68.58	73.66	77.72	85.73	92.33	74.93
30/60	2.900	3.100	3.260	3.575	3.835	3.150	73.66	78.74	82.80	90.81	97.41	80.01
31/62	3.000	3.200	3.360	3.675	3.935	3.250	76.20	81.28	85.34	93.35	99.95	82.55
35/70	3.400	3.600	3.760	4.075	4.335	3.650	86.36	91.44	95.50	103.51	110.11	92.71
36/72	3.500	3.700	3.860	4.175	4.435	3.750	88.90	93.98	98.04	106.05	112.65	95.25
40/80	3.900	4.100	4.260	4.575	4.835	4.150	99.06	104.14	108.20	116.21	122.81	105.41
43/86	4.200	4.400	4.560	4.875	5.135	4.450	106.68	111.76	115.82	123.83	130.43	113.03
44/88	4.300	4.500	4.660	4.975	5.235	4.550	109.22	114.30	118.36	126.37	132.97	115.57
50/100	4.900	5.100	5.260	5.575	5.835	5.150	124.46	129.54	133.60	141.61	148.21	130.81
55/110	5.400	5.600	5.760	6.075	6.335	5.650	137.16	142.24	146.30	154.31	160.91	143.51
60/120	5.900	6.100	6.260	6.575	6.835	6.150	149.86	154.94	159.00	167.01	173.61	156.21
61/122	6.000	6.200	6.360	6.675	6.935	6.250	152.40	157.48	161.54	169.55	176.15	158.75
65/130	6.400	6.600	6.760	7.075	7.335	6.650	162.56	167.64	171.70	179.71	186.31	168.91
70/140	6.900	7.100	7.260	7.575	7.835	7.150	175.26	180.34	184.40	192.41	199.01	181.61



**.100" [2.54 mm] Contact Centers, .550" [13.90 mm] Insulator Height,  
.025" [.64 mm] Square Card Extender**

**SPECIFICATIONS**

- Accommodates .062" ± .008" [1.57 ± 0.20] PC Board
- Insulator Material available in PBT, PPS or PA9T
- 3 Amp Current Rating
- Insulator / Contact Specifications and Part Number Coding See opposite page
- P/N 04-0004-000 for In Between Contact Polarizing Key See Page 204 (Sold Separately)
- Molded-in Key Available - Consult Factory

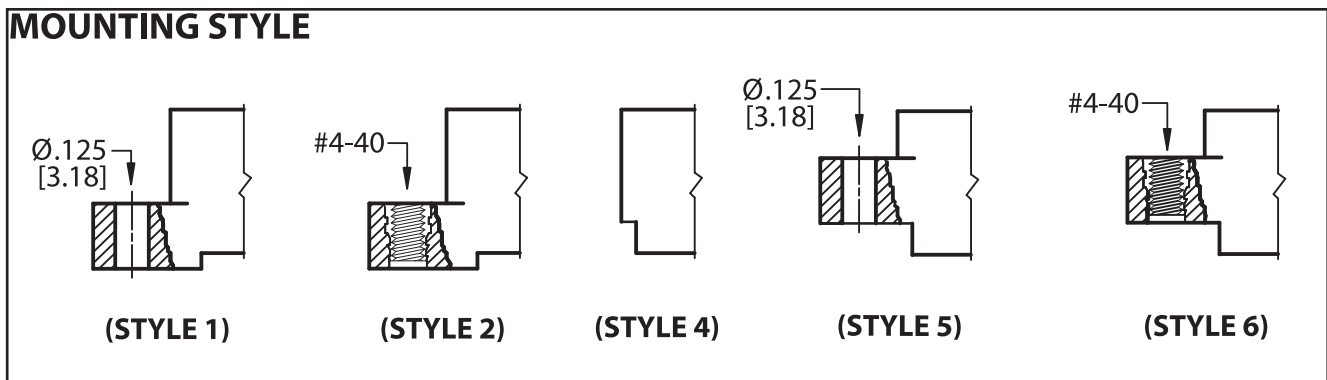
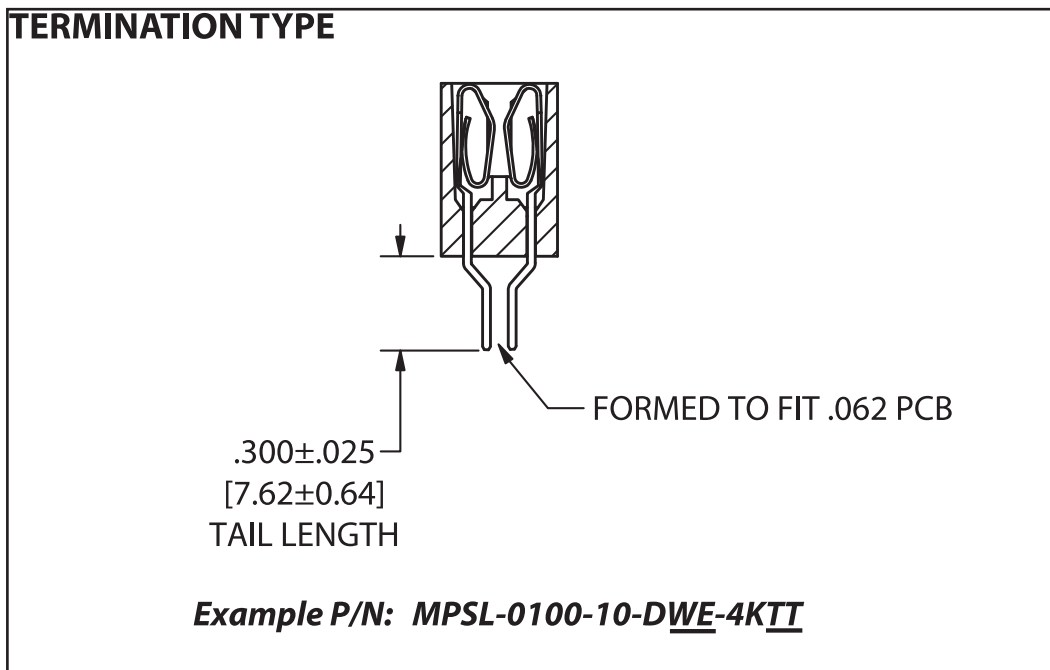
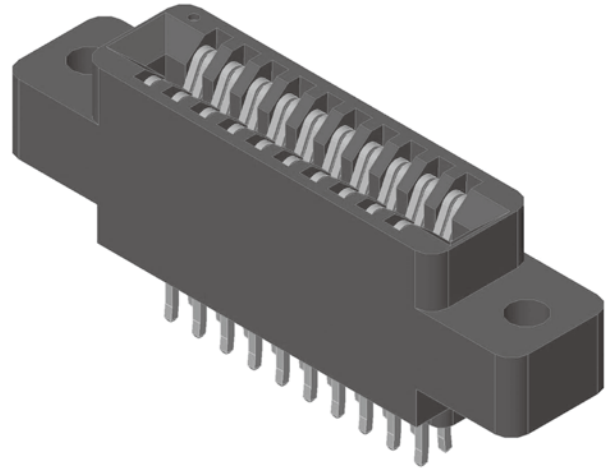

Micro Plastics



**.100" [2.54 mm] Contact Centers, .550" [13.90 mm] Insulator Height, .025" [.64 mm] Square Card Extender**

**PART NUMBER OPTIONS**

**MPSL - 0 100 - 10 - D WE - 4 K TT**

**PLATING - RoHS Compliant**

All Platings are Lead Free and have .000050" Nickel Underplate

**Contact Surface Termination**

\*MPSL = .000010" Gold .000100" Pure Tin, Matte

\*MPL = .000100" Overall Pure Tin, Matte

MP = .000010" Overall Gold

\*Requires 'K' Modification Code

**INSULATOR MATERIAL\*\***

0 = PBT

**CONTACT CENTERS**

100 = .100" [2.54mm]

**NUMBER OF POSITIONS**

Contacts Per Row (See Position Chart Below)

**READOUT**

D = Dual

**MODIFICATION CODE\*\***

TT = No Standoffs

**PLATING MODIFICATION CODE\*\***

K = Required on MPSL or MPL Plating  
Omit for MP Plating (Overall Gold)

**MOUNTING STYLE** (See Opposite Page)

- 1 = .125" Clearance Hole
- 2 = #4-40 Threaded Insert
- 4 = No Mounting
- 5 = Raised, .125" Clearance Hole
- 6 = Raised, #4-40 Threaded Insert

**TERMINATION TYPE** (See Opposite Page)

WE = Card Extender

**\*\* See Pages 160-161 for Specifications and other Variations**

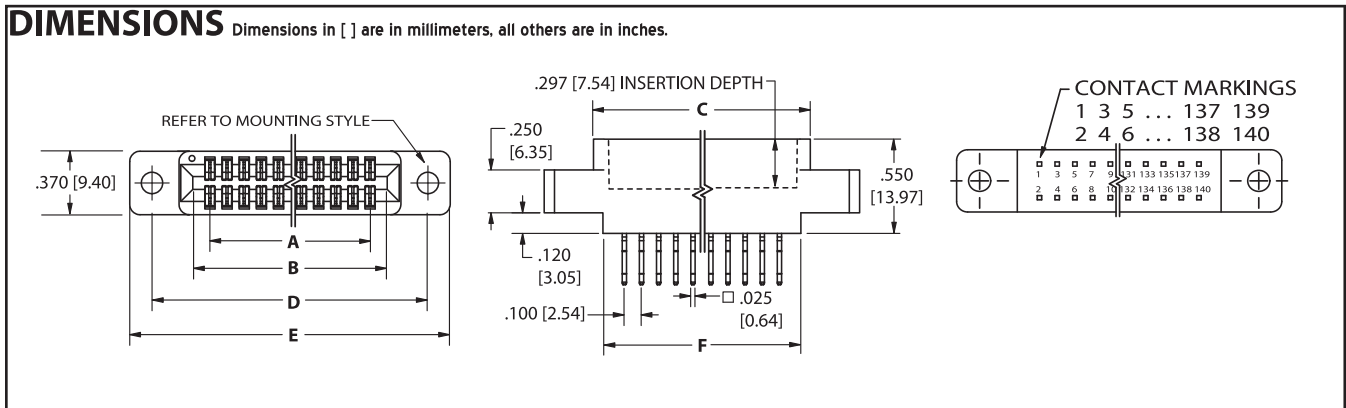

POSITIONS/ CONTACTS	INCHES						[MILLIMETERS]					
	A±.008	B±.008	C±.015	D±.010	E±.020	F±.015	A±0.20	B±0.20	C±0.38	D±0.25	E±0.51	F±0.38
06/12	0.500	0.700	0.860	1.175	1.435	0.750	12.70	17.78	21.84	29.85	36.45	19.05
08/16	0.700	0.900	1.060	1.375	1.635	0.950	17.78	22.86	26.92	34.93	41.53	24.13
10/20	0.900	1.100	1.260	1.575	1.835	1.150	22.86	27.94	32.00	40.01	46.61	29.21
12/24	1.100	1.300	1.460	1.775	2.035	1.350	27.94	33.02	37.08	45.09	51.69	34.29
13/26	1.200	1.400	1.560	1.875	2.135	1.450	30.48	35.56	39.62	47.63	54.23	36.83
15/30	1.400	1.600	1.760	2.075	2.335	1.650	35.56	40.64	44.70	52.71	59.31	41.91
17/34	1.600	1.800	1.960	2.275	2.535	1.850	40.64	45.72	49.78	57.79	64.39	46.99
18/36	1.700	1.900	2.060	2.375	2.635	1.950	43.18	48.26	52.32	60.33	66.93	49.53
20/40	1.900	2.100	2.260	2.575	2.835	2.150	48.26	53.34	57.40	65.41	72.01	54.61
22/44	2.100	2.300	2.460	2.775	3.035	2.350	53.34	58.42	62.48	70.49	77.09	59.69
24/48	2.300	2.500	2.660	2.975	3.235	2.550	58.42	63.50	67.56	75.57	82.17	64.77
25/50	2.400	2.600	2.760	3.075	3.335	2.650	60.96	66.04	70.10	78.11	84.71	67.31
28/56	2.700	2.900	3.060	3.375	3.635	2.950	68.58	73.66	77.72	85.73	92.33	74.93
30/60	2.900	3.100	3.260	3.575	3.835	3.150	73.66	78.74	82.80	90.81	97.41	80.01
31/62	3.000	3.200	3.360	3.675	3.935	3.250	76.20	81.28	85.34	93.35	99.95	82.55
35/70	3.400	3.600	3.760	4.075	4.335	3.650	86.36	91.44	95.50	103.51	110.11	92.71
36/72	3.500	3.700	3.860	4.175	4.435	3.750	88.90	93.98	98.04	106.05	112.65	95.25
40/80	3.900	4.100	4.260	4.575	4.835	4.150	99.06	104.14	108.20	116.21	122.81	105.41
43/86	4.200	4.400	4.560	4.875	5.135	4.450	106.68	111.76	115.82	123.83	130.43	113.03
44/88	4.300	4.500	4.660	4.975	5.235	4.550	109.22	114.30	118.36	126.37	132.97	115.57
50/100	4.900	5.100	5.260	5.575	5.835	5.150	124.46	129.54	133.60	141.61	148.21	130.81
55/110	5.400	5.600	5.760	6.075	6.335	5.650	137.16	142.24	146.30	154.31	160.91	143.51
60/120	5.900	6.100	6.260	6.575	6.835	6.150	149.86	154.94	159.00	167.01	173.61	156.21
61/122	6.000	6.200	6.360	6.675	6.935	6.250	152.40	157.48	161.54	169.55	176.15	158.75
65/130	6.400	6.600	6.760	7.075	7.335	6.650	162.56	167.64	171.70	179.71	186.31	168.91
70/140	6.900	7.100	7.260	7.575	7.835	7.150	175.26	180.34	184.40	192.41	199.01	181.61



**.100" [2.54 mm] Contact Centers, .610" [15.49 mm] Insulator Height,  
Right Angle**

### SPECIFICATIONS

Accommodates .062" ± .008" [1.57 ± 0.20] PC Board  
Insulator Material available in PBT, PPS or PA9T  
3 Amp Current Rating  
Insulator / Contact Specifications and  
Part Number Coding See opposite page  
P/N 04-0004-000 for In Between Contact Polarizing Key  
See Page 204 (Sold Separately)  
Molded-in Key Available - Consult Factory

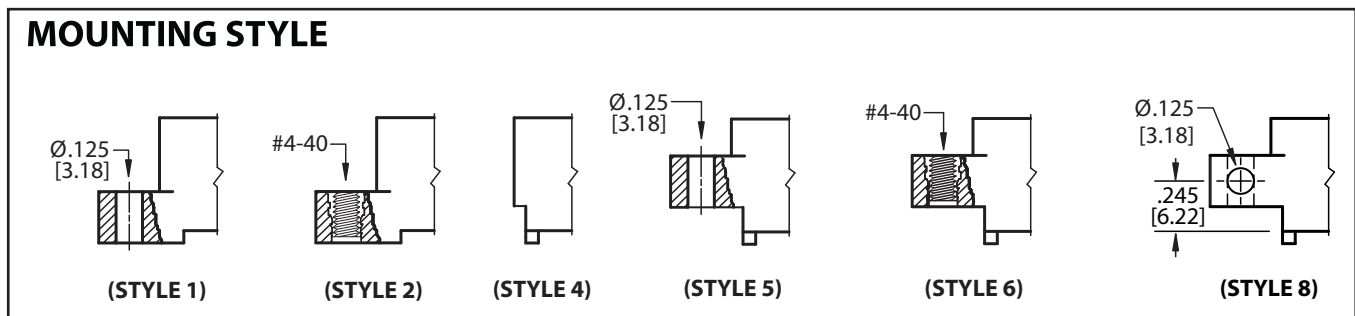
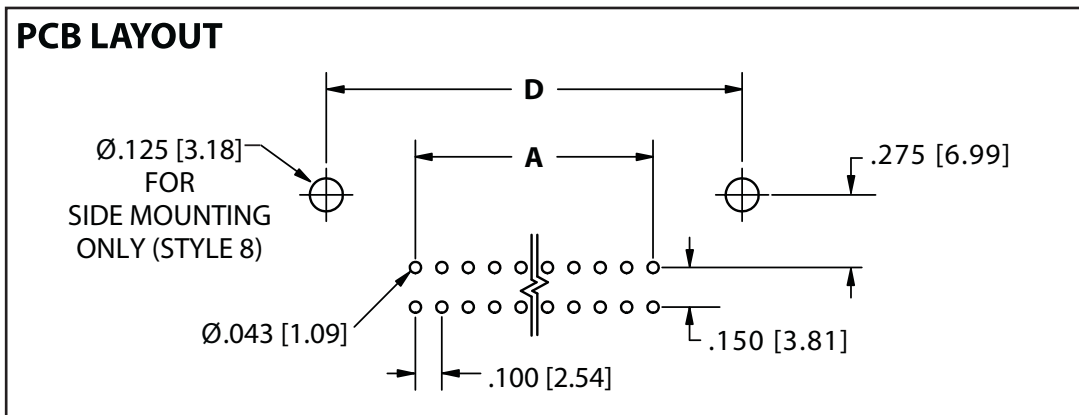
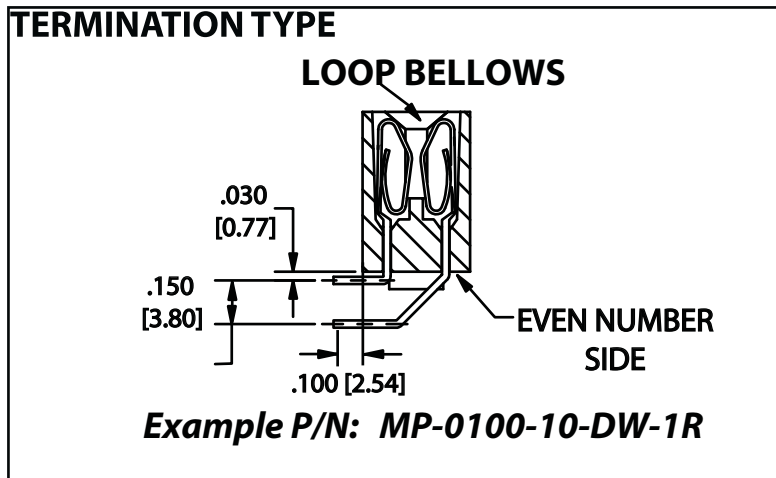
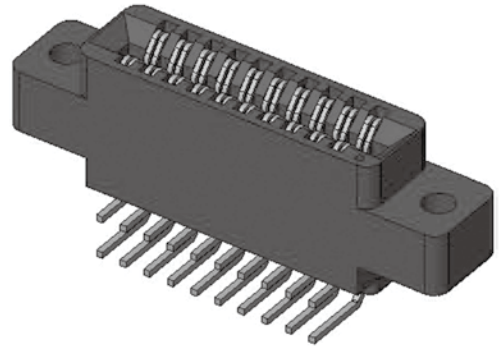

Micro Plastics



**.100" [2.54 mm] Contact Centers, .610" [15.49 mm] Insulator Height, Right Angle**

**PART NUMBER OPTIONS**

**MPSL - 0 100 - 10 - D W - 1 K R**

**PLATING - RoHS Compliant**

All Platings are Lead Free and have .000050" Nickel Underplate Contact Surface Termination  
 \*MPSL = .000010" Gold .000100" Pure Tin, Matte  
 \*MPL = .000100" Overall Pure Tin, Matte  
 MP = .000010" Overall Gold  
 \*Requires 'K' Modification Code

**INSULATOR MATERIAL \*\***

0 = PBT

**CONTACT CENTERS**

100 = .100" [2.54mm]

**NUMBER OF POSITIONS**

Contacts Per Row (See Position Chart Below)

**READOUT**

D = Dual

**MODIFICATION CODE\*\***

R = Right Angle

**PLATING MODIFICATION CODE\*\***

K = Required on MPSL or MPL Plating  
 Omit for MP Plating (Overall Gold)

**MOUNTING STYLE** (See Opposite Page)

- 1 = .125" Clearance Hole
- 2 = #4-40 Threaded Insert
- 4 = No Mounting
- 5 = Raised, .125" Clearance Hole
- 6 = Raised, #4-40 Threaded Insert
- 8 = Raised, Side Mounting, .125" Clearance Hole

**TERMINATION TYPE** (See Opposite Page)

**LOOP BELLOWS**

W = .025 [.64] Square

\*\* See Pages 160-161 for Specifications and other Variations

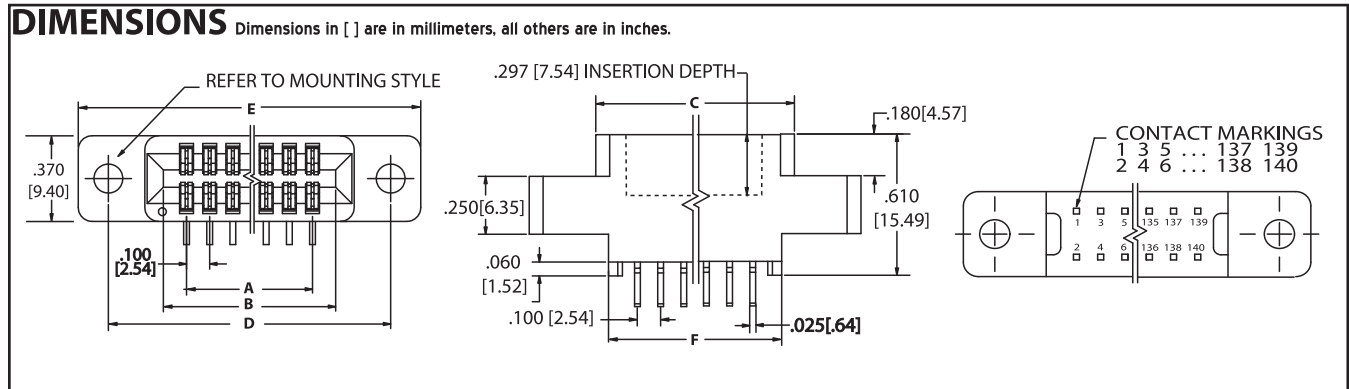

POSITIONS/ CONTACTS	INCHES						[MILLIMETERS]					
	A±.008	B±.008	C±.015	D±.010	E±.020	F±.015	A±0.20	B±0.20	C±0.38	D±0.25	E±0.51	F±0.38
06/12	0.500	0.700	0.860	1.175	1.435	0.750	12.70	17.78	21.84	29.85	36.45	19.05
08/16	0.700	0.900	1.060	1.375	1.635	0.950	17.78	22.86	26.92	34.93	41.53	24.13
10/20	0.900	1.100	1.260	1.575	1.835	1.150	22.86	27.94	32.00	40.01	46.61	29.21
12/24	1.100	1.300	1.460	1.775	2.035	1.350	27.94	33.02	37.08	45.09	51.69	34.29
13/26	1.200	1.400	1.560	1.875	2.135	1.450	30.48	35.56	39.62	47.63	54.23	36.83
15/30	1.400	1.600	1.760	2.075	2.335	1.650	35.56	40.64	44.70	52.71	59.31	41.91
17/34	1.600	1.800	1.960	2.275	2.535	1.850	40.64	45.72	49.78	57.79	64.39	46.99
18/36	1.700	1.900	2.060	2.375	2.635	1.950	43.18	48.26	52.32	60.33	66.93	49.53
20/40	1.900	2.100	2.260	2.575	2.835	2.150	48.26	53.34	57.40	65.41	72.01	54.61
22/44	2.100	2.300	2.460	2.775	3.035	2.350	53.34	58.42	62.48	70.49	77.09	59.69
24/48	2.300	2.500	2.660	2.975	3.235	2.550	58.42	63.50	67.56	75.57	82.17	64.77
25/50	2.400	2.600	2.760	3.075	3.335	2.650	60.96	66.04	70.10	78.11	84.71	67.31
28/56	2.700	2.900	3.060	3.375	3.635	2.950	68.58	73.66	77.72	85.73	92.33	74.93
30/60	2.900	3.100	3.260	3.575	3.835	3.150	73.66	78.74	82.80	90.81	97.41	80.01
31/62	3.000	3.200	3.360	3.675	3.935	3.250	76.20	81.28	85.34	93.35	99.95	82.55
35/70	3.400	3.600	3.760	4.075	4.335	3.650	86.36	91.44	95.50	103.51	110.11	92.71
36/72	3.500	3.700	3.860	4.175	4.435	3.750	88.90	93.98	98.04	106.05	112.65	95.25
40/80	3.900	4.100	4.260	4.575	4.835	4.150	99.06	104.14	108.20	116.21	122.81	105.41
43/86	4.200	4.400	4.560	4.875	5.135	4.450	106.68	111.76	115.82	123.83	130.43	113.03
44/88	4.300	4.500	4.660	4.975	5.235	4.550	109.22	114.30	118.36	126.37	132.97	115.57
50/100	4.900	5.100	5.260	5.575	5.835	5.150	124.46	129.54	133.60	141.61	148.21	130.81
55/110	5.400	5.600	5.760	6.075	6.335	5.650	137.16	142.24	146.30	154.31	160.91	143.51
60/120	5.900	6.100	6.260	6.575	6.835	6.150	149.86	154.94	159.00	167.01	173.61	156.21
61/122	6.000	6.200	6.360	6.675	6.935	6.250	152.40	157.48	161.54	169.55	176.15	158.75
65/130	6.400	6.600	6.760	7.075	7.335	6.650	162.56	167.64	171.70	179.71	186.31	168.91
70/140	6.900	7.100	7.260	7.575	7.835	7.150	175.26	180.34	184.40	192.41	199.01	181.61



**.100" [2.54 mm] Contact Centers, .610" [15.49 mm] Insulator Height,  
Special 18/31 with Barrier, Dip Solder/Wire Wrap, [ISA]**

**SPECIFICATIONS**

- ISA Connector
- Accommodates .062" ± .008" [1.57 ± 0.20] PC Board
- Insulator Material available in PBT, PPS or PA9T
- 3 Amp Current Rating
- Insulator / Contact Specifications and Part Number Options See opposite page
- P/N 04-0004-000 for In Between Contact Polarizing Key See Page 204 (Sold Separately)
- Molded-in Key Available - Consult Factory



**TERMINATION TYPE**

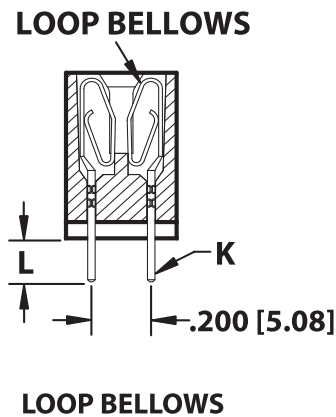

TERMINATION CODE	MODIFICATION CODE	TYPE	POST CROSS SECTION K	POST LENGTH L	FITS MIN. HOLE SIZE	EXAMPLE PART NUMBER
R	H	Dip Solder	.025 [0.64] Round	.190 [4.83]	.033 [0.84]	<i>MPSL-0100-18/31-DR-1HK</i>
R	H(.165)	Dip Solder	.025 [0.64] Round	.165 [4.19]	.033 [0.84]	<i>MPSL-0100-18/31-DR-1HK(.165)</i>
W	H	Dip Solder	.025 [0.64] Square	.190 [4.83]	.040 [1.02]	<i>MPSL-0100-18/31-DW-1HK</i>
W	OMIT	Wire Wrap	.025 [0.64] Square	.560 [14.20]	.040 [1.02]	<i>MPSL-0100-18/31-DW-1K</i>

**MOUNTING STYLE**

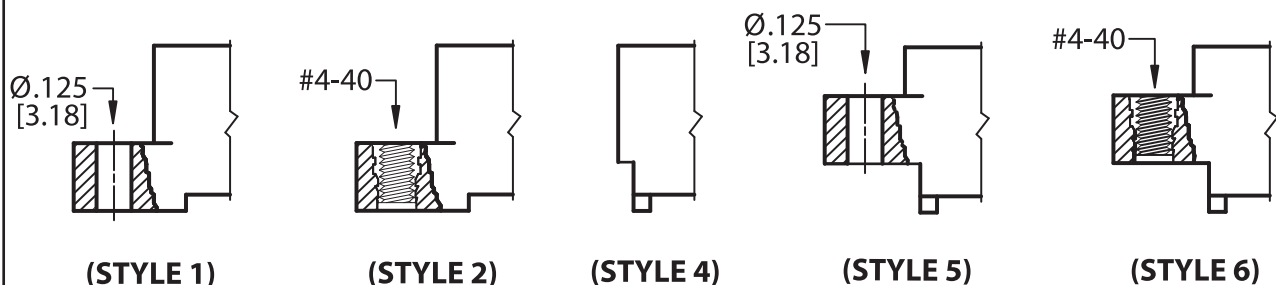

Micro Plastics



**.100" [2.54 mm] Contact Centers, .610" [15.49 mm] Insulator Height,  
Special 18/31 with Barrier, Dip Solder/Wire Wrap, [ISA]**

**PART NUMBER OPTIONS**

**MPSL - 0 100 - 18/31 - D W - 1 H K**

**PLATING - RoHS Compliant**

All Platings are Lead Free and have .000050" Nickel Underplate

**Contact Surface                      Termination**

\*MPSL = .000010" Gold                      .000100" Pure Tin, Matte

\*MPL = .000100" Overall Pure Tin, Matte

MP = .000010" Overall Gold

\*Requires 'K' Modification Code

**INSULATOR MATERIAL \*\***

0 = PBT

**CONTACT CENTERS**

100 = .100" [2.54mm]

**NUMBER OF POSITIONS**

18/31 Per Row

**READOUT**

D = Dual

**PLATING MODIFICATION CODE\*\***

K = Required on MPSL or MPL Plating  
Omit for MP Plating (Overall Gold)

**MODIFICATION CODE\*\***

(See Opposite Page)

H = Dip Solder .190[4.83] Tail Length  
(.025 Round or .025 Square)

H(.165) = Dip Solder .165[4.19] Tail Length  
(.025 Round Only)

**MOUNTING STYLE (See Opposite Page)**

- 1 = .125" Clearance Hole
- 2 = #4-40 Threaded Insert
- 4 = No Mounting
- 5 = Raised, .125" Clearance Hole
- 6 = Raised, #4-40 Threaded Insert

**TERMINATION TYPE (See Opposite Page)**

**LOOP BELLOWS**

- R = .025[.64mm] Round
- W = .025[.64mm] Square

**CONSULT FACTORY FOR RIGHT ANGLE VERSION**

\*\* See Pages 160-161 for Specifications and other Variations

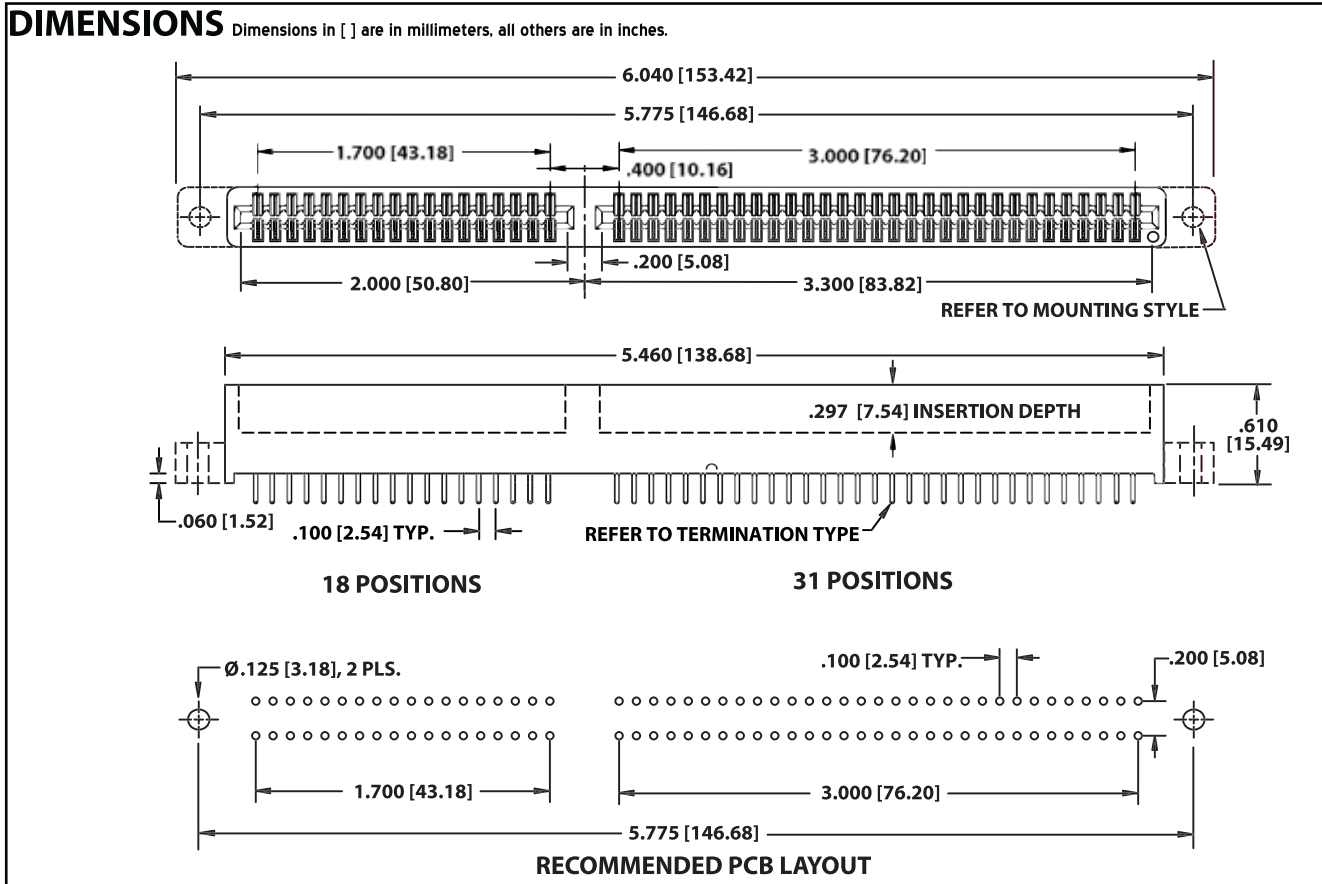

Micro Plastics



**.125" [3.18 mm] Contact Centers, .431" [10.95 mm] Insulator Height,  
Dip Solder**

**SPECIFICATIONS**

- Accommodates .062" ± .008" [1.57 ± 0.20] PC Board
- Insulator Material available in PBT, PPS or PA9T
- 3 Amp Current Rating
- Insulator / Contact Specifications and Part Number Options See opposite page
- Row Spacing Available in .140" or .200" (Use Modification Code 'X9' for .200")
- P/N 04-0003-000 for In Between Contact Polarizing Key See Page 204 (Sold Separately)
- Molded-in Key Available - Consult Factory

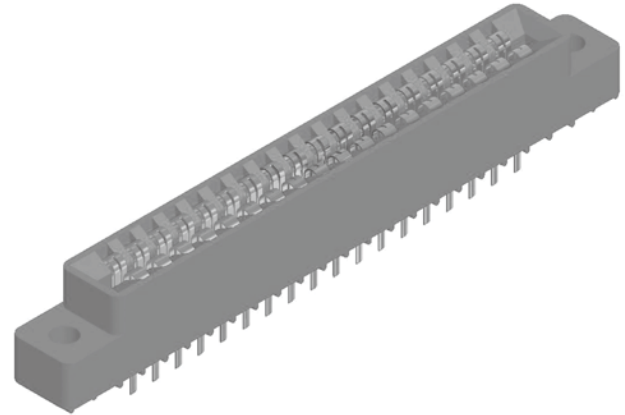

**TERMINATION TYPE**

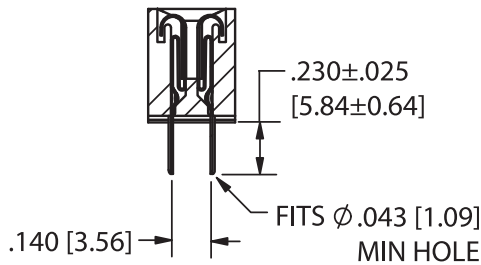

**DIP SOLDER (S)  
.140" ROW SPACING**

*Example P/N: MP~~S~~L-0125-10-DS-1K*

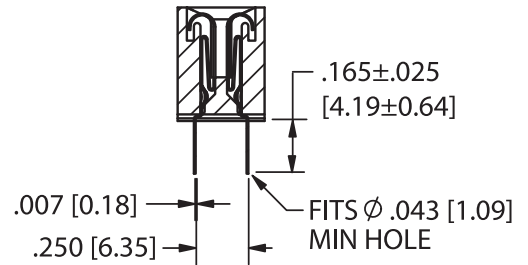

**DIP SOLDER (S)  
.250" ROW SPACING  
REQUIRES 'X9' MODIFICATION CODE**

*Example P/N: MP~~S~~L-0125-10-DS-1KX9*

**MOUNTING STYLE**

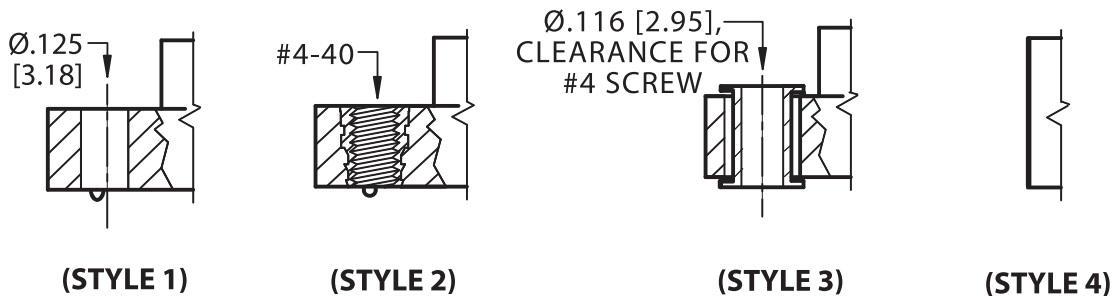

Micro Plastics



**.125" [3.18 mm] Contact Centers, .431" [10.95 mm] Insulator Height, Dip Solder**

**PART NUMBER OPTIONS**

**MPL - 0 125 - 10 - D S - 1 K**

**PLATING - RoHS Compliant**

All Platings are Lead Free and have .000050" Nickel Underplate

- Contact Surface Termination**
- \*MPSL = .000010" Gold .000100" Pure Tin, Matte
  - \*MPL = .000100" Overall Pure Tin, Matte
  - MP = .000010" Overall Gold

\*Requires 'K' Modification Code

**INSULATOR MATERIAL\*\***

0 = PBT

**CONTACT CENTERS**

125 = .125" [3.18mm]

**NUMBER OF POSITIONS**

Contacts Per Row (See Position Chart Below)

**MODIFICATION CODE\*\***

- K = Required on MPSL or MPL Plating  
Omit for MP Plating (Overall Gold)
- X9 = .250" Row Spacing

**MOUNTING STYLE** (See Opposite Page)

- 1 = .125" Clearance Hole
- 2 = #4-40 Threaded Insert
- 3 = Floating Bobbin
- 4 = No Mounting

**TERMINATION TYPE** (See Opposite Page)

S = Dip Solder

**READOUT**

D = Dual

**\*\* See Pages 160-161 for Specifications and other Variations**

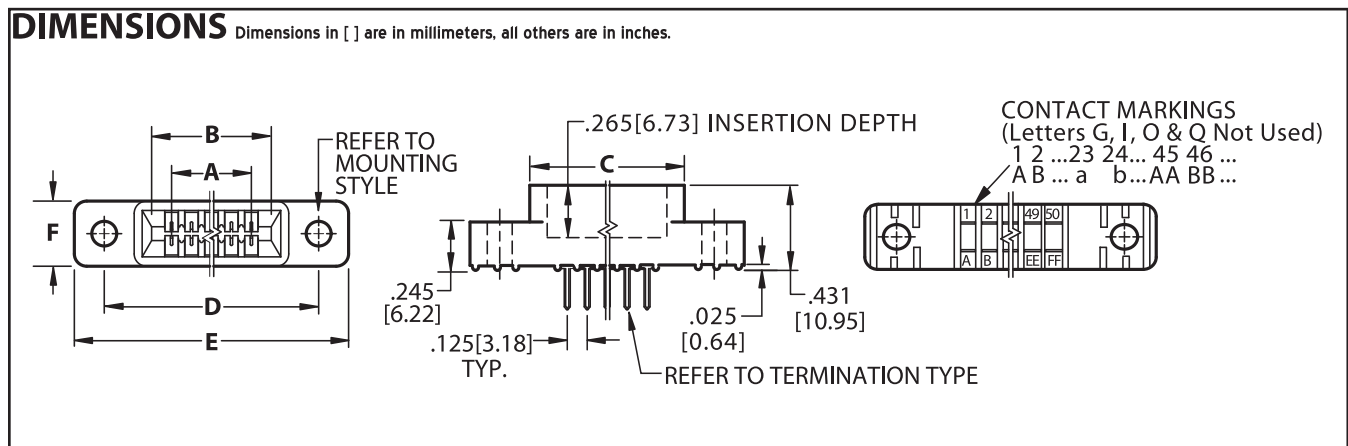

POSITIONS/ CONTACTS	INCHES						MILLIMETERS					
	A±.008	B±.008	C±.015	D±.010	E±.020	F+.005/ -.015	A±0.20	B±0.20	C±0.38	D±0.25	E±0.51	F+0.13/ -0.38
06/12	0.625	0.875	1.035	1.295	1.575	0.330	15.88	22.23	26.29	32.89	40.01	8.38
10/20	1.125	1.375	1.535	1.795	2.075		28.58	34.93	38.99	45.59	52.71	
14/28	1.625	1.875	2.035	2.295	2.575		41.28	47.63	51.69	58.29	65.41	
15/30	1.750	2.000	2.160	2.420	2.700		44.45	50.80	54.86	61.47	68.58	
18/36	2.125	2.375	2.535	2.795	3.075		53.98	60.33	64.39	70.99	78.11	
22/44	2.625	2.875	3.035	3.295	3.575		66.68	73.03	77.09	83.69	90.81	
28/56	3.375	3.625	3.785	4.045	4.325		85.73	92.08	96.14	102.74	109.86	
30/60	3.625	3.875	4.035	4.295	4.575		92.08	98.43	102.49	109.09	116.21	
31/62	3.750	4.000	4.160	4.420	4.700		95.25	101.60	105.66	112.27	119.38	
35/70	4.250	4.500	4.660	4.920	5.200		107.95	114.30	118.36	124.97	132.08	
36/72	4.375	4.625	4.785	5.045	5.325		111.13	117.48	121.54	128.14	135.26	
37/74	4.500	4.750	4.910	5.170	5.450		114.30	120.65	124.71	131.32	138.43	
40/80	4.875	5.125	5.285	5.545	5.825		123.83	130.18	134.24	140.84	147.96	
43/86	5.250	5.500	5.660	5.920	6.200		133.35	139.70	143.76	150.37	157.48	
44/88	5.375	5.625	5.785	6.045	6.325	136.53	142.88	146.94	153.54	160.66		
49/98	6.000	6.250	6.410	6.670	6.950	152.40	158.75	162.81	169.42	176.53		
50/100	6.125	6.375	6.535	6.795	7.075	155.58	161.93	165.99	172.59	179.71		
						0.370						9.40



**.125" [3.18 mm] Contact Centers, .431" [10.95 mm] Insulator Height,  
Card Extender**

**SPECIFICATIONS**

- Accommodates .062" ± .008" [1.57 ± 0.20] PC Board
- Insulator Material available in PBT, PPS or PA9T
- 3 Amp Current Rating
- Insulator / Contact Specifications and Part Number Options See opposite page
- P/N 04-0003-000 for In Between Contact Polarizing Key See Page 204 (Sold Separately)
- Molded-in Key Available - Consult Factory

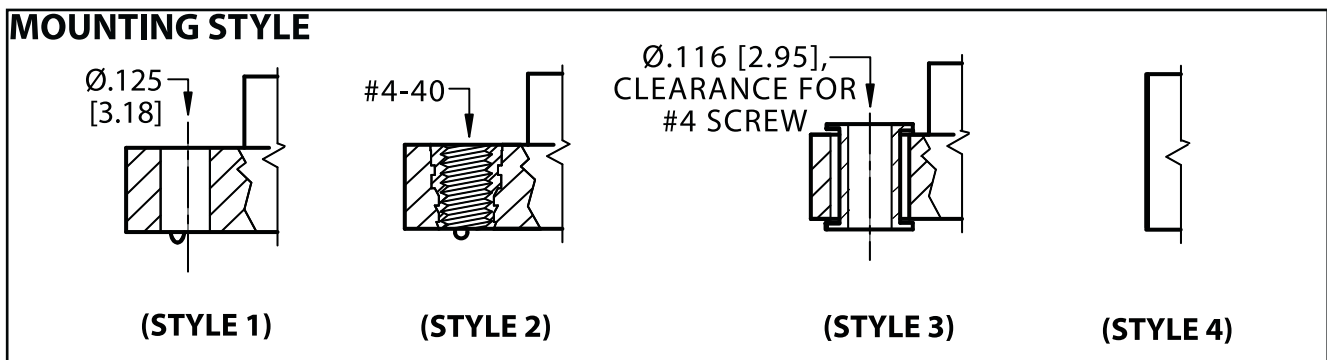
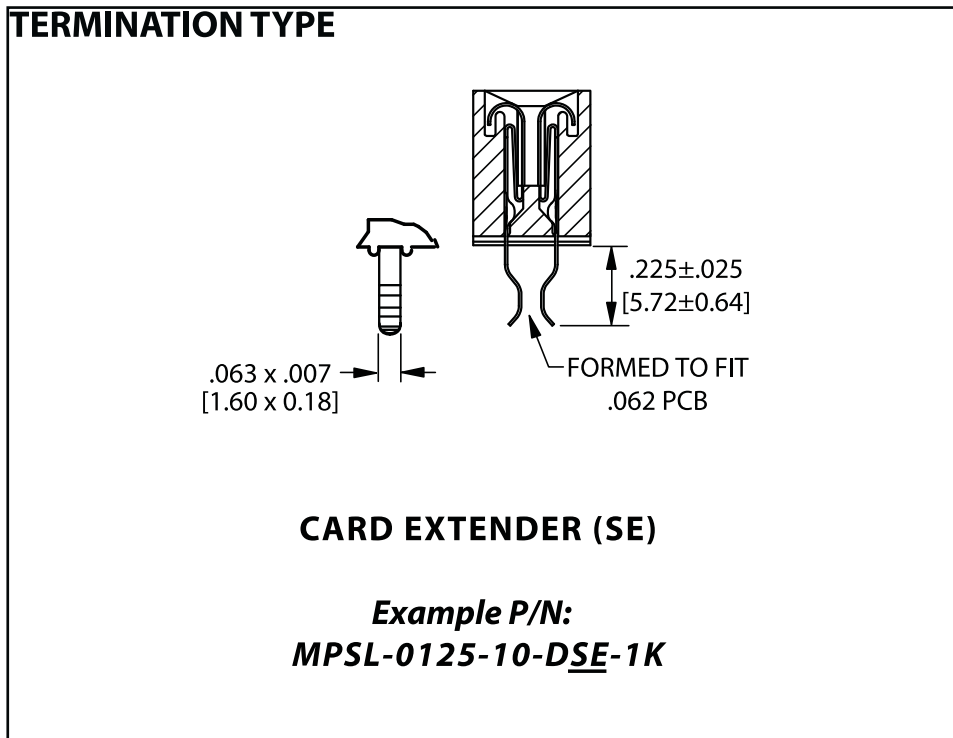



**.125" [3.18 mm] Contact Centers, .431" [10.95 mm] Insulator Height, Card Extender**

**PART NUMBER OPTIONS**

**MPSL - 0 125 - 10 - D SE - 1 K**

**PLATING - RoHS Compliant**

All Platings are Lead Free and have .000050" Nickel Underplate

**Contact Surface Termination**

\*MPSL = .000010" Gold .000100" Pure Tin Matte

\*MPL = .000100" Overall Pure Tin, Matte

MP = .000010" Overall Gold

**\* Requires 'K' Modification Code**

Other Plating and thicknesses available upon request

**INSULATOR MATERIAL\*\***

0 = PBT

**CONTACT CENTERS**

125 = .125" [3.18mm]

**NUMBER OF POSITIONS**

Contacts Per Row (See Position Chart Below)

**PLATING MODIFICATION CODE\*\***

K = Required on MPSL or MPL Plating  
Omit for MP Plating (Overall Gold)

**MOUNTING STYLE** (See Opposite Page)

- 1 = .125" Clearance Hole
- 2 = #4-40 Threaded Insert
- 3 = Floating Bobbin
- 4 = No Mounting

**TERMINATION TYPE** (See Opposite Page)

SE = Card Extender

**READOUT**

D = Dual

**\*\* See Pages 160-161 for Specifications and other Variations**

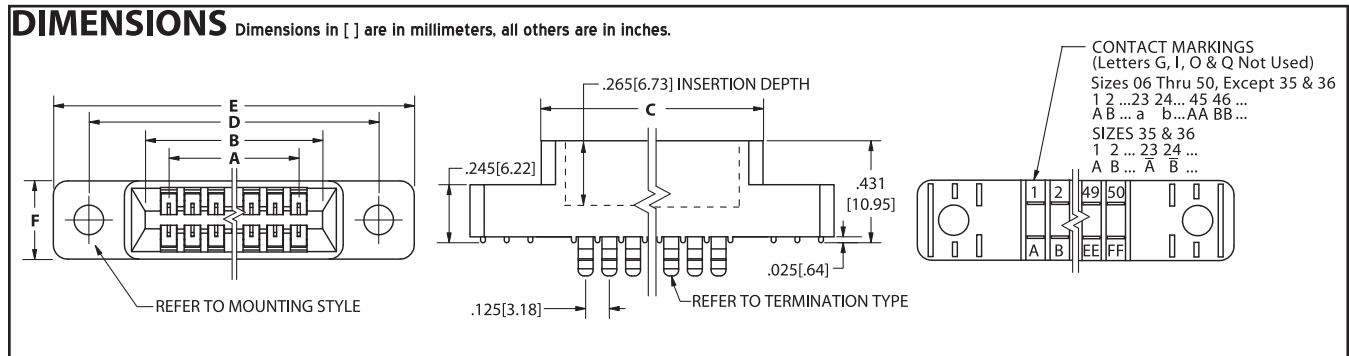

POSITIONS/ CONTACTS	INCHES						MILLIMETERS						
	A±.008	B±.008	C±.015	D±.010	E±.020	F±.005	A±0.20	B±0.20	C±0.38	D±0.25	E±0.51	F±0.13	
06/12	0.625	0.875	1.035	1.295	1.575	0.330	15.88	22.23	26.29	32.89	40.01	8.38	
10/20	1.125	1.375	1.535	1.795	2.075		28.58	34.93	38.99	45.59	52.71		
14/28	1.625	1.875	2.035	2.295	2.575		41.28	47.63	51.69	58.29	65.41		
15/30	1.750	2.000	2.160	2.420	2.700		44.45	50.80	54.86	61.47	68.58		
18/36	2.125	2.375	2.535	2.795	3.075		53.98	60.33	64.39	70.99	78.11		
22/44	2.625	2.875	3.035	3.295	3.575		66.68	73.03	77.09	83.69	90.81		
28/56	3.375	3.625	3.785	4.045	4.325		85.73	92.08	96.14	102.74	109.86		
30/60	3.625	3.875	4.035	4.295	4.575		92.08	98.43	102.49	109.09	116.21		
31/62	3.750	4.000	4.160	4.420	4.700		95.25	101.60	105.66	112.27	119.38		
35/70	4.250	4.500	4.660	4.920	5.200		107.95	114.30	118.36	124.97	132.08		
36/72	4.375	4.625	4.785	5.045	5.325		111.13	117.48	121.54	128.14	135.26		
37/74	4.500	4.750	4.910	5.170	5.450		114.30	120.65	124.71	131.32	138.43		
40/80	4.875	5.125	5.285	5.545	5.825		123.83	130.18	134.24	140.84	147.96		9.40
43/86	5.250	5.500	5.660	5.920	6.200		133.35	139.70	143.76	150.37	157.48		
44/88	5.375	5.625	5.785	6.045	6.325	136.53	142.88	146.94	153.54	160.66			
49/98	6.000	6.250	6.410	6.670	6.950	152.40	158.75	162.81	169.42	176.53			
50/100	6.125	6.375	6.535	6.795	7.075	155.58	161.93	165.99	172.59	179.71			



**.125" [3.18 mm] Contact Centers, .431" [10.95 mm] Insulator Height, Eyelet**

**SPECIFICATIONS**

- Accommodates .062" ± .008" [1.57 ± 0.20] PC Board
- Insulator Material available in PBT, PPS or PA9T
- 3 Amp Current Rating
- Insulator / Contact Specifications and Part Number Options See opposite page
- P/N 04-0004-000 for In Between Contact Polarizing Key See Page 204 (Sold Separately)
- Molded-in Key Available - Consult Factory

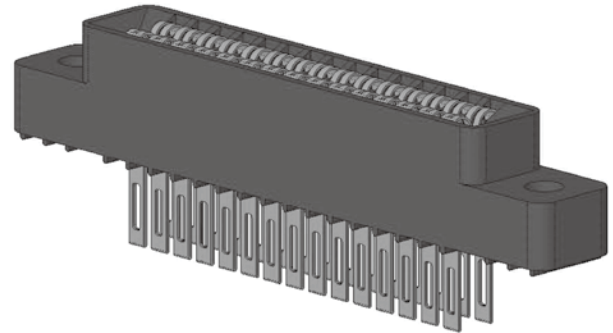

**TERMINATION TYPE**

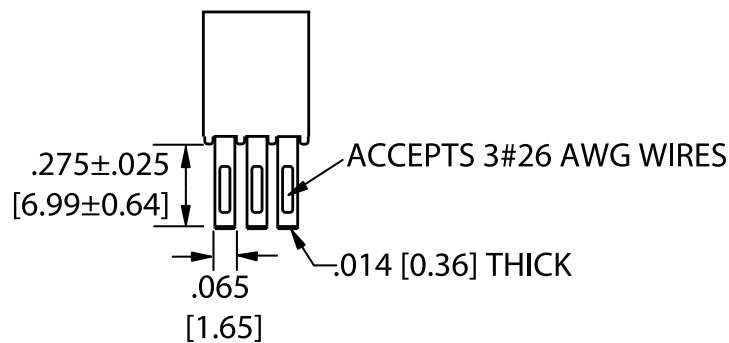

**EYELET (P)**

**Example P/N:  
MP-0125-10-DP-1**

**MOUNTING STYLE**

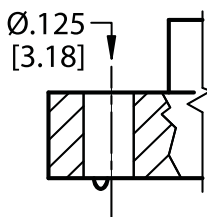

**(STYLE 1)**

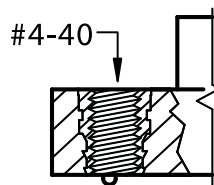

**(STYLE 2)**

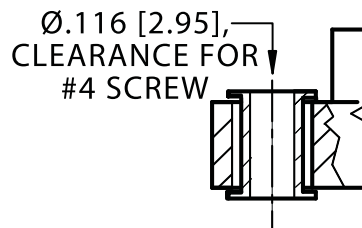

**(STYLE 3)**

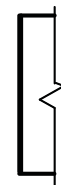

**(STYLE 4)**



**.125" [3.18 mm] Contact Centers, .431" [10.95 mm] Insulator Height, Eyelet**

**PART NUMBER OPTIONS**

**MPL - 0 125 - 10 - D P - 1 K**

**PLATING - RoHS Compliant**

All Platings are Lead Free and have .000050" Nickel Underplate

\*MPL = .000100" Overall Pure Tin, Matte

MP = .000010" Overall Gold

**\* Requires 'K' Modification Code**

Other Plating and thicknesses available upon request

**PLATING MODIFICATION CODE\*\***

K = Required on Tin Plating

Omit for MP Plating (Overall Gold)

**INSULATOR MATERIAL\*\***

0 = PBT

**MOUNTING STYLE** (See Opposite Page)

1 = .125" Clearance Hole

2 = #4-40 Threaded Insert

3 = Floating Bobbin

4 = No Mounting

**CONTACT CENTERS**

125 = .125" [3.18mm]

**TERMINATION TYPE** (See Opposite Page)

P = Pierced Eyelet, .014" Thick

**NUMBER OF POSITIONS**

Contacts Per Row (See Position Chart Below)

**READOUT**

D = Dual

**\*\* See Pages 160-161 for Specifications and other Variations**

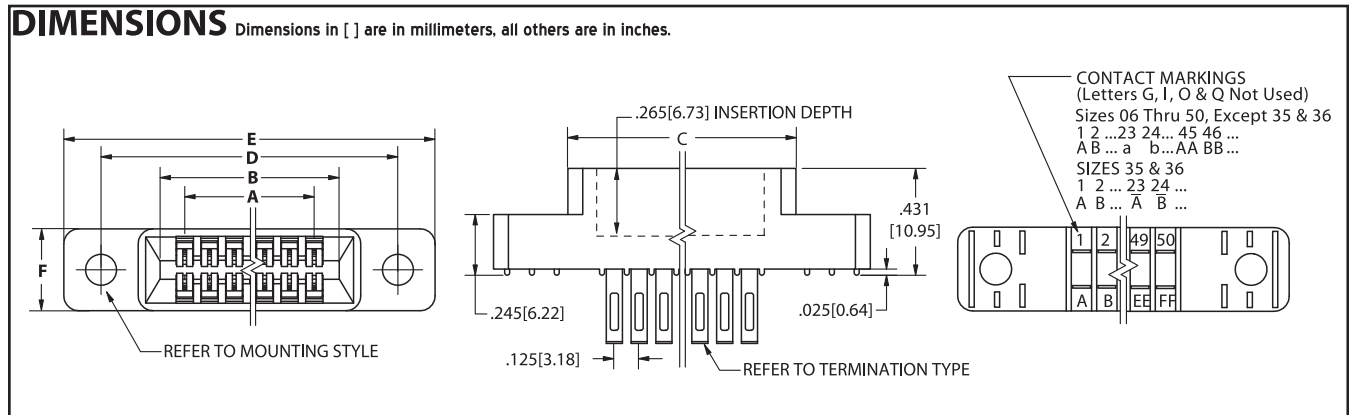

POSITIONS/ CONTACTS	INCHES						MILLIMETERS					
	A±.008	B±.008	C±.015	D±.010	E±.020	F±.005	A±0.20	B±0.20	C±0.38	D±0.25	E±0.51	F±0.13
06/12	0.625	0.875	1.035	1.295	1.575	0.330	15.88	22.23	26.29	32.89	40.01	8.38
10/20	1.125	1.375	1.535	1.795	2.075		28.58	34.93	38.99	45.59	52.71	
14/28	1.625	1.875	2.035	2.295	2.575		41.28	47.63	51.69	58.29	65.41	
15/30	1.750	2.000	2.160	2.420	2.700		44.45	50.80	54.86	61.47	68.58	
18/36	2.125	2.375	2.535	2.795	3.075		53.98	60.33	64.39	70.99	78.11	
22/44	2.625	2.875	3.035	3.295	3.575		66.68	73.03	77.09	83.69	90.81	
28/56	3.375	3.625	3.785	4.045	4.325		85.73	92.08	96.14	102.74	109.86	
30/60	3.625	3.875	4.035	4.295	4.575		92.08	98.43	102.49	109.09	116.21	
31/62	3.750	4.000	4.160	4.420	4.700		95.25	101.60	105.66	112.27	119.38	
35/70	4.250	4.500	4.660	4.920	5.200		107.95	114.30	118.36	124.97	132.08	
36/72	4.375	4.625	4.785	5.045	5.325		111.13	117.48	121.54	128.14	135.26	
37/74	4.500	4.750	4.910	5.170	5.450		114.30	120.65	124.71	131.32	138.43	
40/80	4.875	5.125	5.285	5.545	5.825	0.370	123.83	130.18	134.24	140.84	147.96	9.40
43/86	5.250	5.500	5.660	5.920	6.200		133.35	139.70	143.76	150.37	157.48	
44/88	5.375	5.625	5.785	6.045	6.325		136.53	142.88	146.94	153.54	160.66	
49/98	6.000	6.250	6.410	6.670	6.950		152.40	158.75	162.81	169.42	176.53	
50/100	6.125	6.375	6.535	6.795	7.075		155.58	161.93	165.99	172.59	179.71	



**.125" [3.18 mm] Contact Centers, .610" [15.49 mm] Insulator Height,  
Wire Wrap & Dip Solder**

**SPECIFICATIONS**

- Accommodates .062" ± .008" [1.57 ± 0.20] PC Board
- Insulator Material available in PBT, PPS or PA9T
- 3 Amp Current Rating
- Insulator / Contact Specifications and Part Number Options See opposite page
- P/N 04-0004-000 for In Between Contact Polarizing Key See Page 204 (Sold Separately)
- Molded-in Key Available - Consult Factory

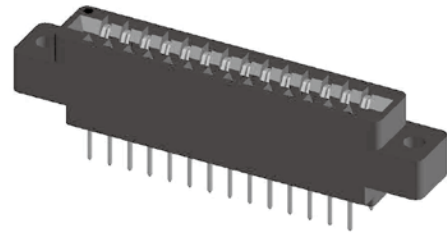

**TERMINATION TYPE**

**LOOP BELLOWS**

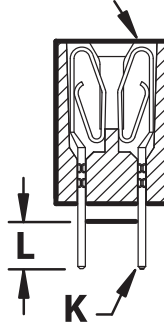

**LOOP BELLOWS**

TERMINATION CODE	MODIFICATION CODE	TYPE	POST CROSS SECTION K	POST LENGTH L	FITS MIN. HOLE SIZE	EXAMPLE PART NUMBER
R	H	Dip Solder	.025 [0.64] Round	.190 [4.83]	.033 [0.84]	<i>MPSL-0125-10-DR-1HK</i>
R	H(.165)	Dip Solder	.025 [0.64] Round	.165 [4.19]	.033 [0.84]	<i>MPSL-0125-10-DR-1HK(.165)</i>
W	H	Dip Solder	.025 [0.64] Square	.190 [4.83]	.040 [1.02]	<i>MPSL-0125-10-DW-1HK</i>
W	OMIT	Wire Wrap	.025 [0.64] Square	.560 [14.20]	.040 [1.02]	<i>MPSL-0125-10-DW-1K</i>

**MOUNTING STYLE**

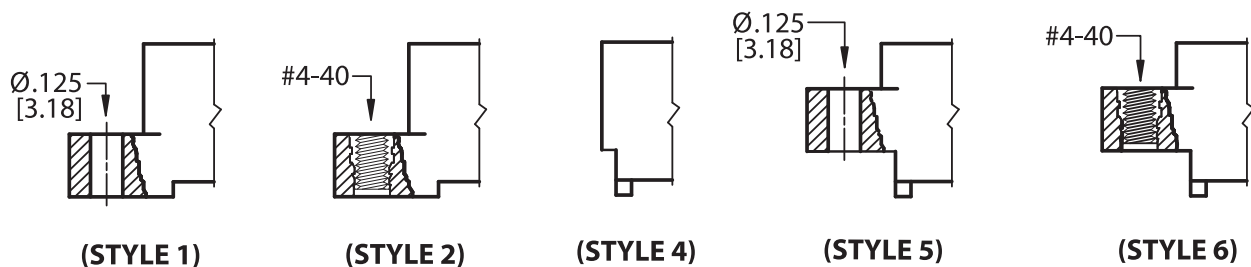

Micro Plastics



**PART NUMBER OPTIONS**

**MPSL - 0 125 - 10 - D W - 1 H K**

**PLATING - RoHS Compliant**

All Platings are Lead Free and have .000050" Nickel Underplate

**Contact Surface Termination**

\*MPSL = .000010" Gold .000100" Pure Tin, Matte

\*MPL = .000100" Overall Pure Tin, Matte

MP = .000010" Overall Gold

**\*Requires 'K' Modification Code**

**PLATING MODIFICATION CODE\*\***

K = Required on MPSL or MPL Plating  
Omit for MP Plating (Overall Gold)

**MODIFICATION CODE\*\***

(See Opposite Page)

H = Dip Solder .190[4.83] Tail Length  
(.025 Round or .025 Square)

H(.165) = Dip Solder .165[4.19] Tail Length  
(.025 Round Only)

**INSULATOR MATERIAL\*\***

0 = PBT

**CONTACT CENTERS**

125 = .125" [3.18mm]

**NUMBER OF POSITIONS**

Contacts Per Row (See Position Chart Below)

**READOUT**

D = Dual

**MOUNTING STYLE** (See Opposite Page)

1 = .125" Clearance Hole

2 = #4-40 Threaded Insert

4 = No Mounting

5 = Raised, .125" Clearance Hole

6 = Raised, #4-40 Threaded Insert

**TERMINATION TYPE** (See Opposite Page)

**LOOP BELLOWS**

R = .025[.64mm] Round

W = .025[.64mm] Square

**\*\* See Pages 160-161 for Specifications and other Variations**

**DIMENSIONS**

Dimensions in [ ] are in millimeters, all others are in inches.

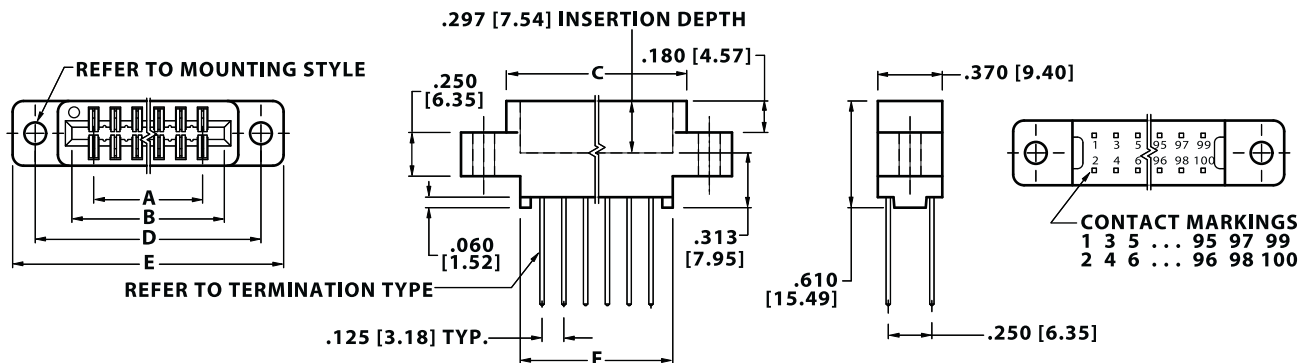

POSITIONS/ CONTACTS	INCHES						MILLIMETERS					
	A±.008	B±.008	C±.015	D±.010	E±.020	F±.015	A±0.20	B±0.20	C±0.38	D±0.25	E±0.51	F±0.38
06/12	0.625	0.875	1.035	1.295	1.555	0.875	15.88	22.23	26.29	32.89	39.50	22.23
10/20	1.125	1.375	1.535	1.795	2.055	1.375	28.58	34.93	38.99	45.59	52.20	34.93
14/28	1.625	1.875	2.035	2.295	2.555	1.875	41.28	47.63	51.69	58.29	64.90	47.63
15/30	1.750	2.000	2.160	2.420	2.680	2.000	44.45	50.80	54.86	61.47	68.07	50.80
18/36	2.125	2.375	2.535	2.795	3.055	2.375	53.98	60.33	64.39	70.99	77.60	60.33
22/44	2.625	2.875	3.035	3.295	3.555	2.875	66.68	73.03	77.09	83.69	90.30	73.03
24/48	2.875	3.125	3.285	3.545	3.805	3.125	73.03	79.38	83.44	90.04	96.65	79.38
28/56	3.375	3.625	3.785	4.045	4.305	3.625	85.73	92.08	96.14	102.74	109.35	92.08
30/60	3.625	3.875	4.035	4.295	4.555	3.875	92.08	98.43	102.49	109.09	115.70	98.43
31/62	3.750	4.000	4.160	4.420	4.680	4.000	95.25	101.60	105.66	112.27	118.87	101.60
32/64	3.875	4.125	4.285	4.545	4.805	4.125	98.43	104.78	108.84	115.44	122.05	104.78
35/70	4.250	4.500	4.660	4.920	5.180	4.500	107.95	114.30	118.36	124.97	131.57	114.30
36/72	4.375	4.625	4.785	5.045	5.305	4.625	111.13	117.48	121.54	128.14	134.75	117.48
40/80	4.875	5.125	5.285	5.545	5.805	5.125	123.83	130.18	134.24	140.84	147.45	130.18
43/86	5.250	5.500	5.660	5.920	6.180	5.500	133.35	139.70	143.76	150.37	156.97	139.70
44/88	5.375	5.625	5.785	6.045	6.305	5.625	136.53	142.88	146.94	153.54	160.15	142.88
49/98	6.000	6.250	6.410	6.670	6.930	6.250	152.40	158.75	162.81	169.42	176.02	158.75
50/100	6.125	6.375	6.535	6.795	7.055	6.375	155.58	161.93	165.99	172.59	179.20	161.93



**.125" [3.18 mm] Contact Centers, .550" [13.90 mm] Insulator Height,  
.025" [.64 mm] Square Card Extender**

**SPECIFICATIONS**

- Accommodates .062" ± .008" [1.57 ± 0.20] PC Board
- Insulator Material available in PBT, PPS or PA9T
- 3 Amp Current Rating
- Insulator / Contact Specifications and Part Number Options See opposite page
- P/N 04-0004-000 for In Between Contact Polarizing Key See Page 204 (Sold Separately)
- Molded-in Key Available - Consult Factory

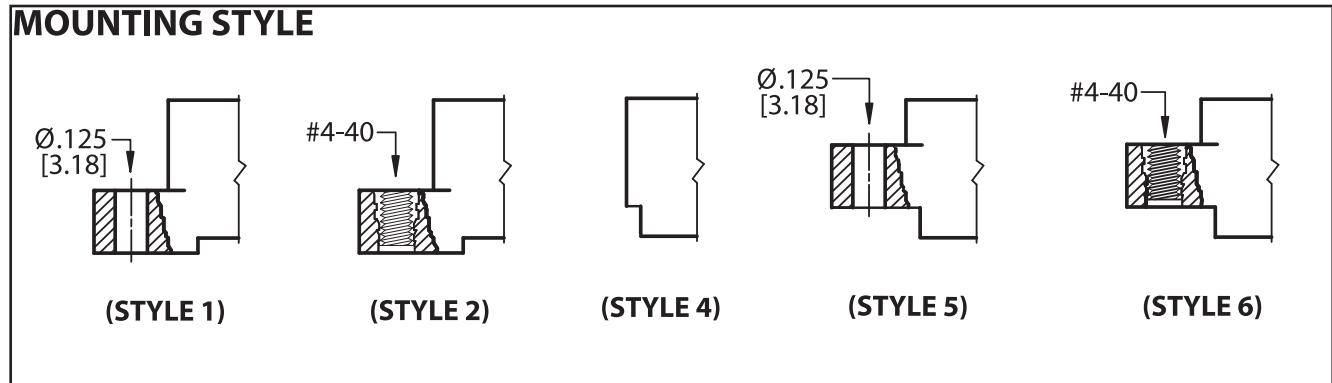
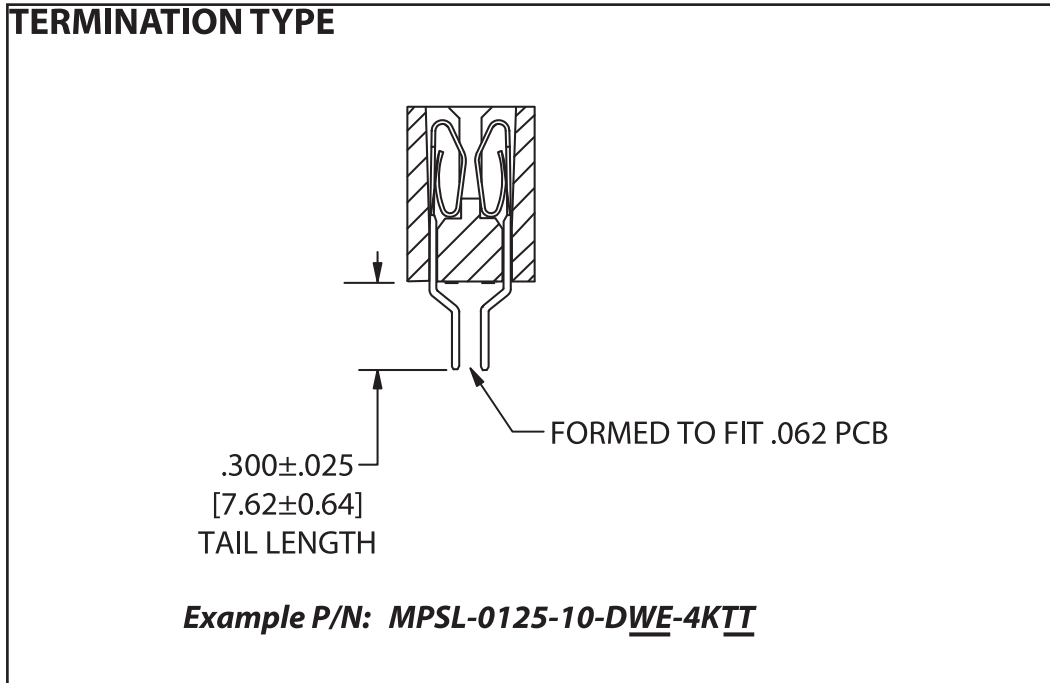
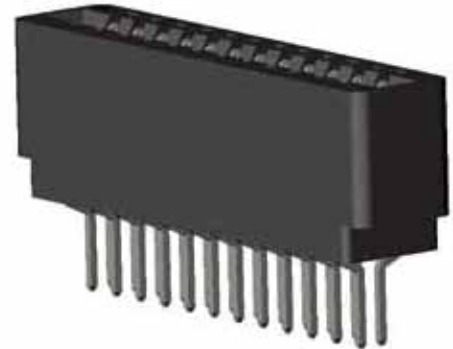

Micro Plastics



**.125" [3.18 mm] Contact Centers, .550" [13.90 mm] Insulator Height, .025" [.64 mm] Square Card Extender**

**PART NUMBER OPTIONS**

**MPSL - 0 125 - 10 - D WE - 4 K TT**

**PLATING - RoHS Compliant**  
All Platings are Lead Free and have .000050" Nickel Underplate

Contact Surface	Termination
*MPSL = .000010" Gold	.000100" Pure Tin, Matte
*MPL = .000100" Overall Pure Tin, Matte	
MP = .000010" Overall Gold	

\*Requires 'K' Modification Code

**INSULATOR MATERIAL\*\***  
0 = PBT

**CONTACT CENTERS**  
125 = .125" [3.18mm]

**NUMBER OF POSITIONS**  
Contacts Per Row (See Position Chart Below)

**READOUT**  
D = Dual

**MODIFICATION CODE\*\***  
TT = No Standoffs

**PLATING MODIFICATION CODE\*\***  
K = Required on MPSL or MPL Plating  
Omit for MP Plating (Overall Gold)

**MOUNTING STYLE** (See Opposite Page)  
1 = .125" Clearance Hole  
2 = #4-40 Threaded Insert  
4 = No Mounting  
5 = Raised, .125" Clearance Hole  
6 = Raised, #4-40 Threaded Insert

**TERMINATION TYPE** (See Opposite Page)  
WE = Card Extender

\*\* See Pages 160-161 for Specifications and other Variations

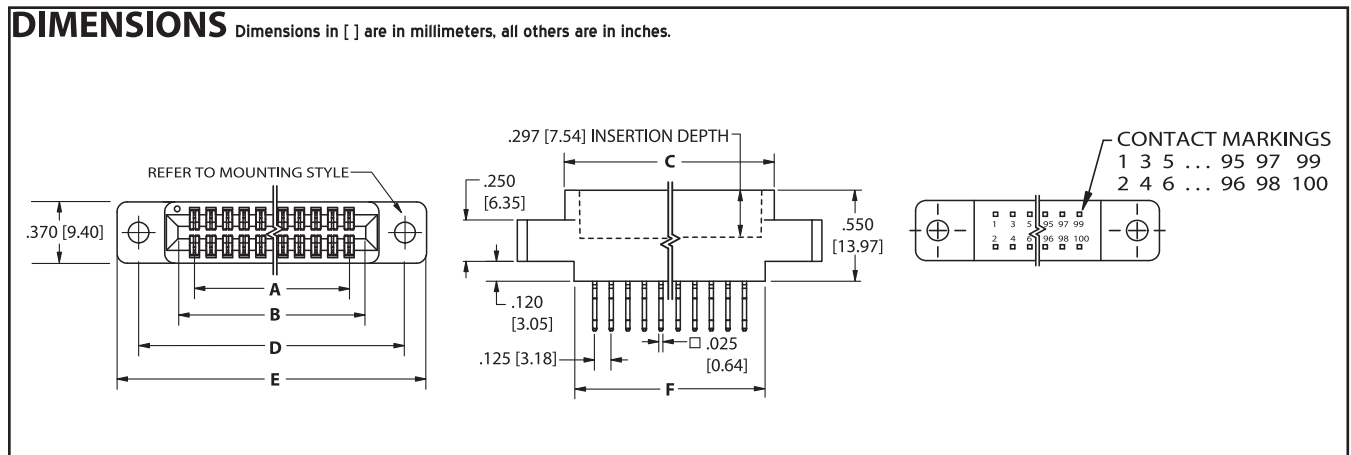

POSITIONS/ CONTACTS	INCHES						MILLIMETERS					
	A±.008	B±.008	C±.015	D±.010	E±.020	F±.015	A±0.20	B±0.20	C±0.38	D±0.25	E±0.51	F±0.38
06/12	0.625	0.875	1.035	1.295	1.555	0.875	15.88	22.23	26.29	32.89	39.50	22.23
10/20	1.125	1.375	1.535	1.795	2.055	1.375	28.58	34.93	38.99	45.59	52.20	34.93
14/28	1.625	1.875	2.035	2.295	2.555	1.875	41.28	47.63	51.69	58.29	64.90	47.63
15/30	1.750	2.000	2.160	2.420	2.680	2.000	44.45	50.80	54.86	61.47	68.07	50.80
18/36	2.125	2.375	2.535	2.795	3.055	2.375	53.98	60.33	64.39	70.99	77.60	60.33
22/44	2.625	2.875	3.035	3.295	3.555	2.875	66.68	73.03	77.09	83.69	90.30	73.03
24/48	2.875	3.125	3.285	3.545	3.805	3.125	73.03	79.38	83.44	90.04	96.65	79.38
28/56	3.375	3.625	3.785	4.045	4.305	3.625	85.73	92.08	96.14	102.74	109.35	92.08
30/60	3.625	3.875	4.035	4.295	4.555	3.875	92.08	98.43	102.49	109.09	115.70	98.43
31/62	3.750	4.000	4.160	4.420	4.680	4.000	95.25	101.60	105.66	112.27	118.87	101.60
32/64	3.875	4.125	4.285	4.545	4.805	4.125	98.43	104.78	108.84	115.44	122.05	104.78
35/70	4.250	4.500	4.660	4.920	5.180	4.500	107.95	114.30	118.36	124.97	131.57	114.30
36/72	4.375	4.625	4.785	5.045	5.305	4.625	111.13	117.48	121.54	128.14	134.75	117.48
40/80	4.875	5.125	5.285	5.545	5.805	5.125	123.83	130.18	134.24	140.84	147.45	130.18
43/86	5.250	5.500	5.660	5.920	6.180	5.500	133.35	139.70	143.76	150.37	156.97	139.70
44/88	5.375	5.625	5.785	6.045	6.305	5.625	136.53	142.88	146.94	153.54	160.15	142.88
49/98	6.000	6.250	6.410	6.670	6.930	6.250	152.40	158.75	162.81	169.42	176.02	158.75
50/100	6.125	6.375	6.535	6.795	7.055	6.375	155.58	161.93	165.99	172.59	179.20	161.93



**.125" [3.18 mm] Contact Centers, .610" [15.49 mm] Insulator Height, Right Angle**

**SPECIFICATIONS**

- Accommodates .062" ± .008" [1.57 ± 0.20] PC Board
- Insulator Material available in PBT, PPS or PA9T
- 3 Amp Current Rating
- Insulator / Contact Specifications and Part Number Options See opposite page
- P/N 04-0004-000 for In Between Contact Polarizing Key See Page 204 (Sold Separately)
- Molded-in Key Available - Consult Factory

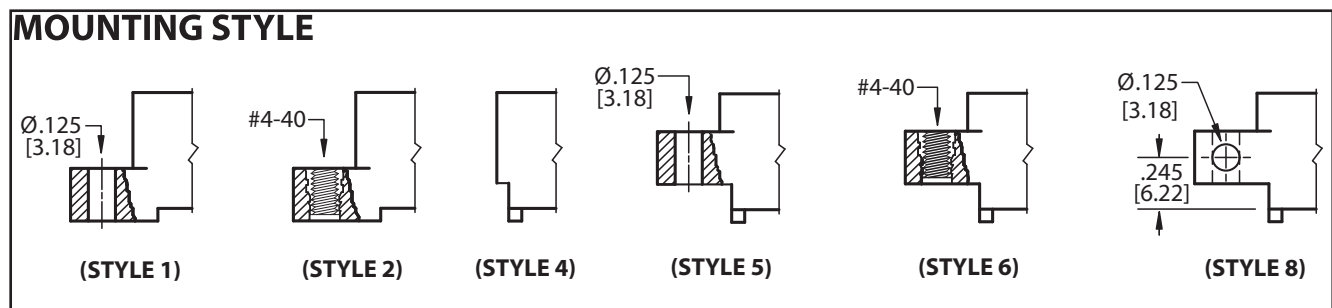
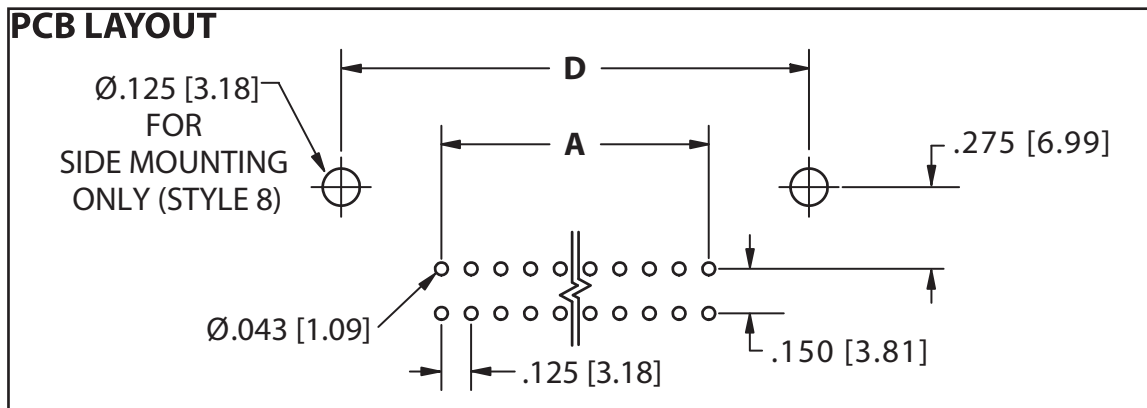
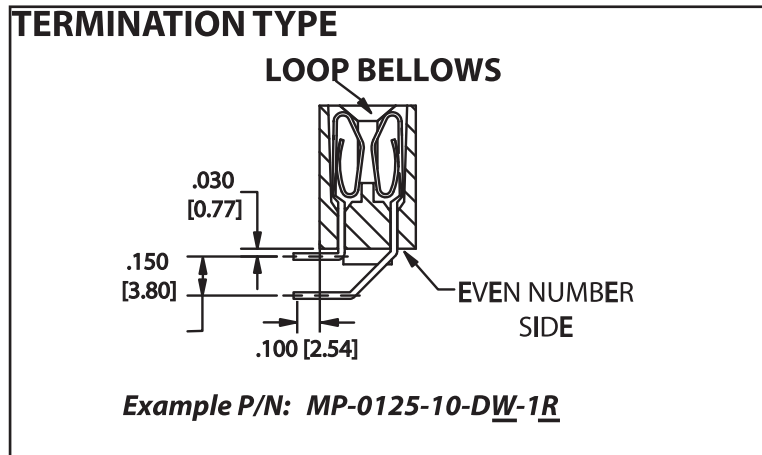
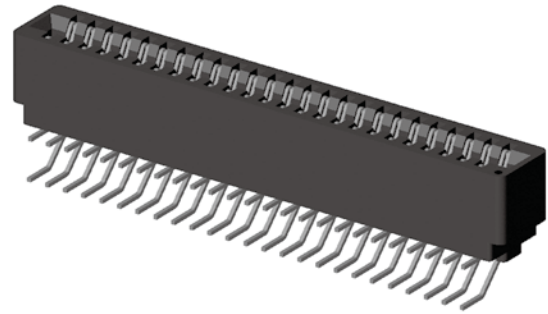



**.125" [3.18 mm] Contact Centers, .610" [15.49 mm] Insulator Height, Right Angle**

**PART NUMBER OPTIONS**

**MPSL - 0 125 - 10 - D W - 1 K R**

**PLATING - RoHS Compliant**

All Platings are Lead Free and have .000050" Nickel Underplate

**Contact Surface Termination**

- \*MPSL = .000010" Gold .000100" Pure Tin, Matte
- \*MPL = .000100" Overall Pure Tin, Matte
- MP = .000010" Overall Gold

\*Requires 'K' Modification Code

**INSULATOR MATERIAL\*\***

0 = PBT

**CONTACT CENTERS**

125 = .125" [3.18mm]

**NUMBER OF POSITIONS**

Contacts Per Row (See Position Chart Below)

**READOUT**

D = Dual

**MODIFICATION CODE\*\***

R = Right Angle

**PLATING MODIFICATION CODE\*\***

K = Required on MPSL or MPL Plating  
Omit for MP Plating (Overall Gold)

**MOUNTING STYLE** (See Opposite Page)

- 1 = .125" Clearance Hole
- 2 = #4-40 Threaded Insert
- 4 = No Mounting
- 5 = Raised, .125" Clearance Hole
- 6 = Raised, #4-40 Threaded Insert
- 8 = Raised, Side Mounting, .125" Clearance Hole

**TERMINATION TYPE** (See Opposite Page)

**LOOP BELLOWS**

W = .025 [.64] Square

**\*\* See Pages 160-161 for Specifications and other Variations**

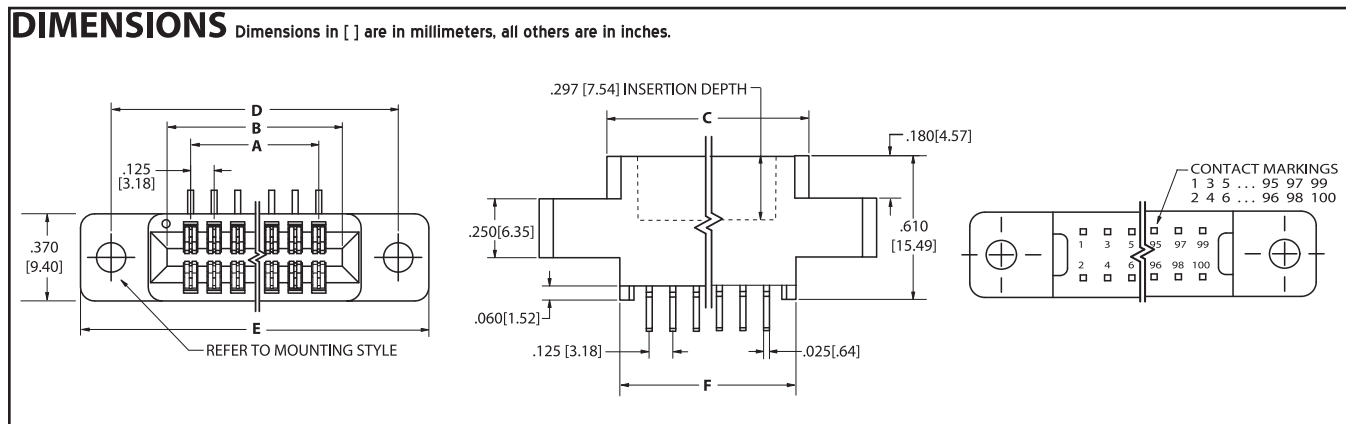

POSITIONS/ CONTACTS	INCHES						MILLIMETERS					
	A±.008	B±.008	C±.015	D±.010	E±.020	F±.015	A±0.20	B±0.20	C±0.38	D±0.25	E±0.51	F±0.38
06/12	0.625	0.875	1.035	1.295	1.555	0.875	15.88	22.23	26.29	32.89	39.50	22.23
10/20	1.125	1.375	1.535	1.795	2.055	1.375	28.58	34.93	38.99	45.59	52.20	34.93
14/28	1.625	1.875	2.035	2.295	2.555	1.875	41.28	47.63	51.69	58.29	64.90	47.63
15/30	1.750	2.000	2.160	2.420	2.680	2.000	44.45	50.80	54.86	61.47	68.07	50.80
18/36	2.125	2.375	2.535	2.795	3.055	2.375	53.98	60.33	64.39	70.99	77.60	60.33
22/44	2.625	2.875	3.035	3.295	3.555	2.875	66.68	73.03	77.09	83.69	90.30	73.03
24/48	2.875	3.125	3.285	3.545	3.805	3.125	73.03	79.38	83.44	90.04	96.65	79.38
28/56	3.375	3.625	3.785	4.045	4.305	3.625	85.73	92.08	96.14	102.74	109.35	92.08
30/60	3.625	3.875	4.035	4.295	4.555	3.875	92.08	98.43	102.49	109.09	115.70	98.43
31/62	3.750	4.000	4.160	4.420	4.680	4.000	95.25	101.60	105.66	112.27	118.87	101.60
32/64	3.875	4.125	4.285	4.545	4.805	4.125	98.43	104.78	108.84	115.44	122.05	104.78
35/70	4.250	4.500	4.660	4.920	5.180	4.500	107.95	114.30	118.36	124.97	131.57	114.30
36/72	4.375	4.625	4.785	5.045	5.305	4.625	111.13	117.48	121.54	128.14	134.75	117.48
40/80	4.875	5.125	5.285	5.545	5.805	5.125	123.83	130.18	134.24	140.84	147.45	130.18
43/86	5.250	5.500	5.660	5.920	6.180	5.500	133.35	139.70	143.76	150.37	156.97	139.70
44/88	5.375	5.625	5.785	6.045	6.305	5.625	136.53	142.88	146.94	153.54	160.15	142.88
49/98	6.000	6.250	6.410	6.670	6.930	6.250	152.40	158.75	162.81	169.42	176.02	158.75
50/100	6.125	6.375	6.535	6.795	7.055	6.375	155.58	161.93	165.99	172.59	179.20	161.93



**.150" [3.81 mm] Contact Centers, .550" [13.90 mm] Insulator Height,  
.025" [.64 mm] Square & .026" [.66 mm] Round Dip Solder**

**SPECIFICATIONS**

- Accommodates .062" ± .008" [1.57 ± 0.20] PC Board
- Insulator Material available in PBT, PPS or PA9T
- 3 Amp Current Rating
- Insulator / Contact Specifications and Part Number Options See opposite page
- P/N 04-0004-000 for In Between Contact Polarizing Key See Page 204 (Sold Separately)
- Molded-in Key Available - Consult Factory

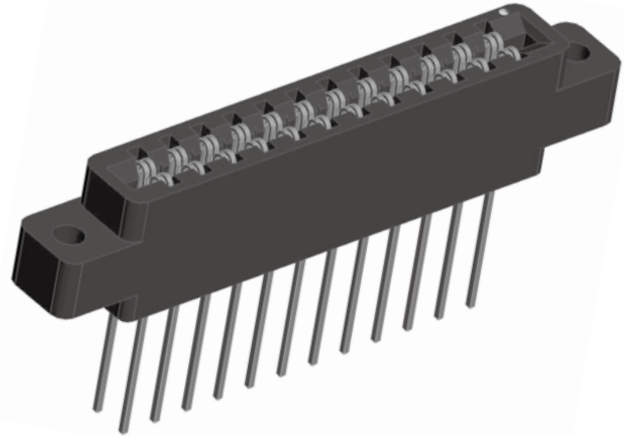

**TERMINATION TYPE**

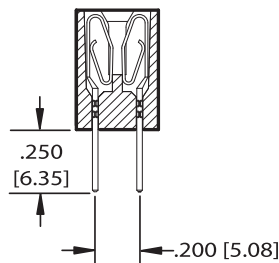

**.250 [6.35] TAIL LENGTH**

Termination Code	Modification Code	Termination Type	Fits Min. Hole Size	Example Part Number
W	H	.025[.64] Sq	.040[1.02]	<b><i>MPSL-0150-18-DW-1HK</i></b>
R	H	.025[.64] Round	.033[0.84]	<b><i>MPSL-0150-18-DR-1HK</i></b>

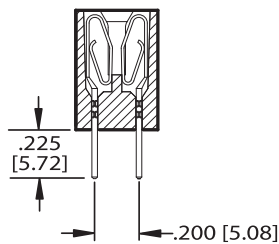

**.225 [5.72] TAIL LENGTH**

Termination Code	Modification Code	Termination Type	Fits Min. Hole Size	Example Part Number
R	H(.225)	.025[.64] Round	.033[0.84]	<b><i>MPSL-0150-18-DR-1HK(.225)</i></b>

**MOUNTING STYLE**

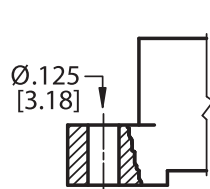

(STYLE 1)

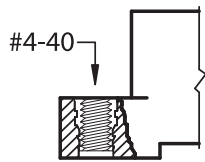

(STYLE 2)



(STYLE 4)

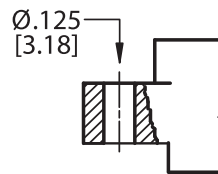

(STYLE 5)

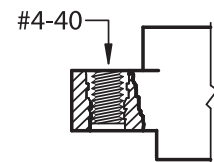

(STYLE 6)



**.150" [3.81 mm] Contact Centers, .550" [13.90 mm] Insulator Height, .025" [.64 mm] Square & .025" [.66 mm] Round Dip Solder**

**PART NUMBER OPTIONS**

**MPSL - 0 150 - 18 - D W - 1 H K**

**PLATING - RoHS Compliant**

All Platings are Lead Free and have .000050" Nickel Underplate

**Contact Surface Termination**

\*MPSL = .000010" Gold .000100" Pure Tin Matte

\*MPL = .000100" Overall Pure Tin, Matte

MP = .000010" Overall Gold

\* Requires 'K' Modification Code

**INSULATOR MATERIAL\*\***

0 = PBT

**CONTACT CENTERS**

150 = .150" [3.81mm]

**NUMBER OF POSITIONS**

Contacts Per Row (See Position Chart Below)

**READOUT**

D = Dual

**PLATING MODIFICATION CODE\*\***

K = Required on MPSL or MPL Plating  
Omit for MP Plating (Overall Gold)

**MODIFICATION CODE\*\***

(See Opposite Page)

H = Dip Solder .250[6.35] Tail Length  
(.025 Round or .025 Square)

H(.225) = Dip Solder .225[5.72] Tail Length  
(.025 Round Only)

**MOUNTING STYLE** (See Opposite Page)

- 1 = .125" Clearance Hole
- 2 = #4-40 Threaded Insert
- 4 = No Mounting
- 5 = Raised, .125" Clearance Hole
- 6 = Raised, #4-40 Threaded Insert

**TERMINATION TYPE** (See Opposite Page)

**LOOP BELLOWS**

- W = .025[.64mm] Square
- R = .025[.64mm] Round

**\*\* See Pages 160-161 for Specifications and other Variations**

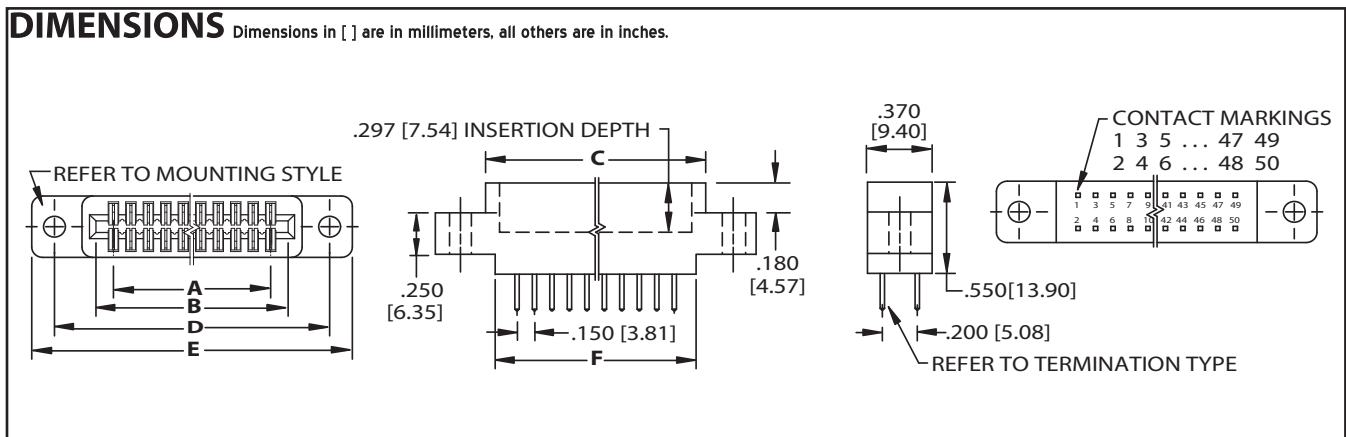

POSITIONS/ CONTACTS	INCHES						[MILLIMETERS]					
	A±.010	B±.010	C±.015	D±.015	E±.020	F±.015	A±0.25	B±0.25	C±0.38	D±0.38	E±0.51	F±0.20
18/36	2.550	2.850	2.990	3.300	3.550	2.840	64.77	72.39	75.95	83.82	90.17	72.14
25/50	3.600	3.900	4.040	-----	-----	3.890	91.44	99.06	102.62	-----	-----	98.81
26/52	3.750	4.050	4.190	4.500	4.750	4.040	95.25	102.87	106.43	114.30	120.65	102.62
28/56	4.050	4.350	4.490	4.800	5.050	4.340	102.87	110.49	114.05	121.92	128.27	110.24
32/64	4.650	4.950	5.090	5.400	5.650	4.940	118.11	125.73	129.29	137.16	143.51	125.48
50/100	7.350	7.650	7.800	-----	-----	7.640	186.69	194.31	198.12	-----	-----	194.06



**.156" [3.96 mm] Contact Centers, .431" [10.95 mm] Insulator Height,  
Dip Solder**

**SPECIFICATIONS**

- Accommodates .062" ± .008" [1.57 ± 0.20] PC Board
- Insulator Material available in PBT, PPS or PA9T
- 3 Amp Current Rating
- Insulator / Contact Specifications and Part Number Options See opposite page
- Row Spacing Available in .140" or .200" (Use Modification Code 'E9' or 'X9' for .200")
- P/N 04-0003-000 for In Between Contact Polarizing Key  
P/N 04-0002-000 for In Contact Polarizing Key  
See Page 204 (Sold Separately)
- Molded-in Key Available - Consult Factory

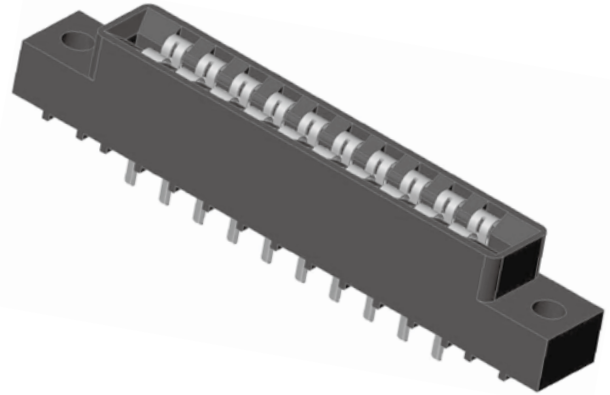

**TERMINATION TYPE**

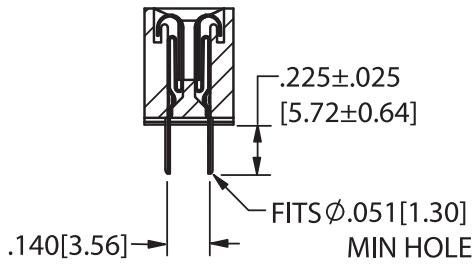

**DIP SOLDER (S)  
.140" ROW SPACING**

*Example P/N: MPSL-0156-10-DS-1K*

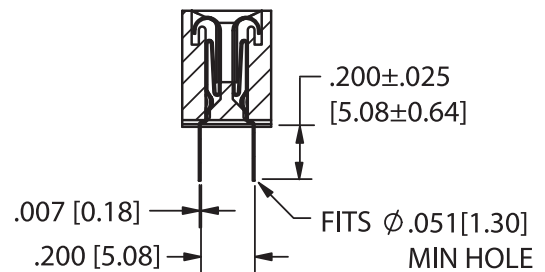

**DIP SOLDER (S)  
.200" ROW SPACING  
REQUIRES 'X9' MODIFICATION CODE**

*Example P/N: MPSL-0156-10-DS-1X9K*

**MOUNTING STYLE**

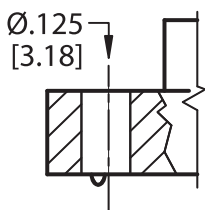

**(STYLE 1)**

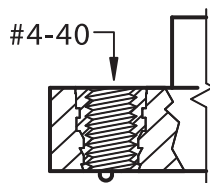

**(STYLE 2)**

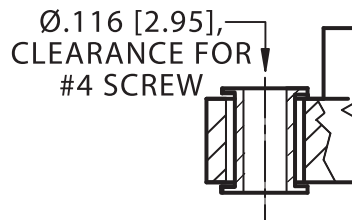

**(STYLE 3)**



**(STYLE 4)**

Micro Plastics



**.156" [3.96 mm] Contact Centers, .431" [10.95 mm] Insulator Height, Dip Solder**

**PART NUMBER OPTIONS**

**MPSL - 0 156 - 10 - D S - 1 K**

**PLATING - RoHS Compliant**

All Platings are Lead Free and have .000050" Nickel Underplate

**Contact Surface Termination**

- \*MPSL = .000010" Gold .000100" Pure Tin, Matte
- \*MPL = .000100" Overall Pure Tin, Matte
- MP = .000010" Overall Gold

\*Requires 'K' Modification Code

**INSULATOR MATERIAL\*\***

0 = PBT

**CONTACT CENTERS**

156 = .156" [3.96mm]

**NUMBER OF POSITIONS**

Contacts Per Row (See Position Chart Below)

**MODIFICATION CODE\*\***

- K = Required on MPSL or MPL Plating  
Omit for MP Plating (Overall Gold)
- E9, X9 = .200" Row Spacing

**MOUNTING STYLE** (See Opposite Page)

- 1 = .125" Clearance Hole
- 2 = #4-40 Threaded Insert
- 3 = Floating Bobbin
- 4 = No Mounting

**TERMINATION TYPE** (See Opposite Page)

S = Dip Solder

**READOUT**

D = Dual

\*\* See Pages 160-161 for Specifications and other Variations

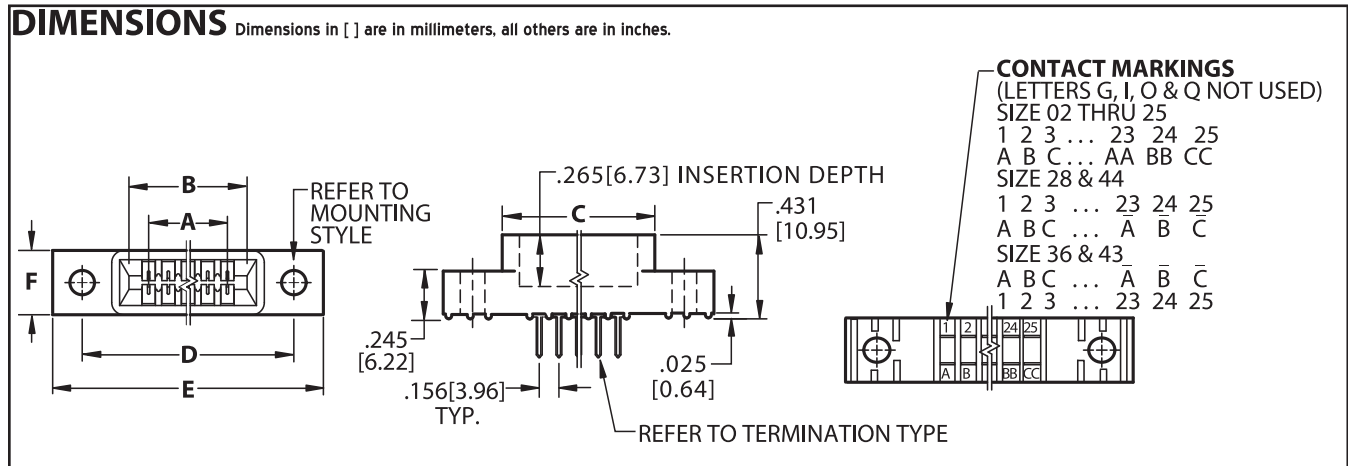

POSITIONS/ CONTACTS	INCHES					F±.005	[MILLIMETERS]					F±.013
	A±.008	B±.008	C±.015	D±.010	E MAX		A±0.20	B±0.20	C±0.38	D±0.25	E MAX	
02/04	0.156	0.476	0.596	'N' MOUNTING		0.325	3.96	12.09	15.14	'N' MOUNTING		8.26
03/06	0.312	0.632	0.752	'N' MOUNTING			7.92	16.05	19.10	'N' MOUNTING		
06/12	0.780	1.100	1.220	1.533	1.902		19.81	27.94	30.99	38.94	48.31	
08/16	1.092	1.412	1.532	1.845	2.214		27.74	35.86	38.91	46.86	56.24	
10/20	1.404	1.724	1.844	2.157	2.526		35.66	43.79	46.84	54.79	64.16	
11/22	1.560	1.880	2.000	2.313	2.682		39.62	47.75	50.80	58.75	68.12	
12/24	1.716	2.036	2.156	2.469	2.838		43.59	51.71	54.76	62.71	72.09	
15/30	2.184	2.504	2.624	2.937	3.306		55.47	63.60	66.65	74.60	83.97	
18/36	2.652	2.972	3.092	3.405	3.774		67.36	75.49	78.54	86.49	95.86	
22/44	3.276	3.596	3.716	4.029	4.398		83.21	91.34	94.39	102.34	111.71	
24/48	3.588	3.908	4.028	4.341	4.710		91.14	99.26	102.31	110.26	119.63	
25/50	3.744	4.064	4.184	4.497	4.866		95.10	103.23	106.27	114.22	123.60	
28/56	4.212	4.532	4.652	4.965	5.334		106.98	115.11	118.16	126.11	135.48	
36/72	5.460	5.780	5.900	6.213	6.582		138.68	146.81	149.86	157.81	167.18	
43/86	6.552	6.872	6.992	7.305	7.674		166.42	174.55	177.60	185.55	194.92	
44/88	6.708	7.028	7.148	7.461	7.830	170.38	178.51	181.56	189.51	198.88		



**.156" [3.96 mm] Contact Centers, .431" [10.95 mm] Insulator Height,  
Card Extender**

**SPECIFICATIONS**

- Accommodates .062" ± .008" [1.57 ± 0.20] PC Board
- Insulator Material available in PBT, PPS or PA9T
- 3 Amp Current Rating
- Insulator / Contact Specifications and Part Number Options See opposite page
- P/N 04-0003-000 for In Between Contact Polarizing Key
- P/N 04-0002-000 for In Contact Polarizing Key
- See Page 204 (Sold Separately)
- Molded-in Key Available - Consult Factory

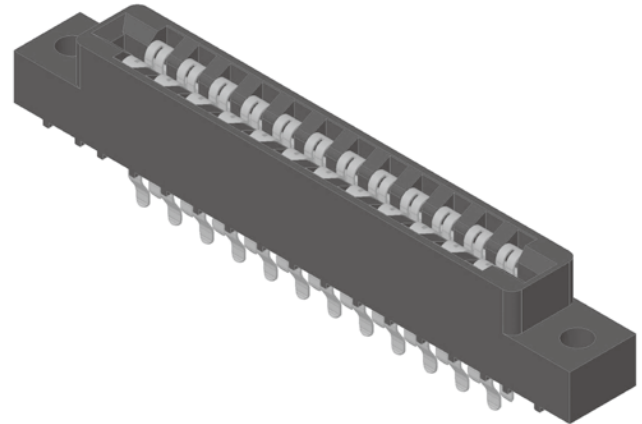

**TERMINATION TYPE**

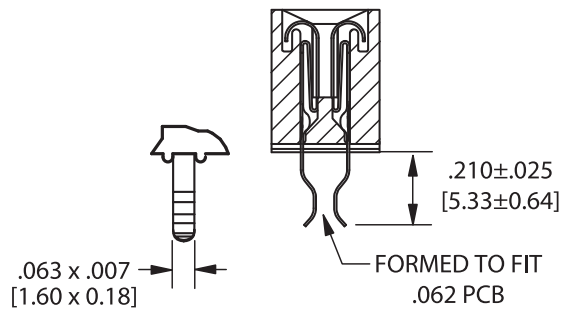

**CARD EXTENDER (SE)**

*Example P/N: MP~~S~~L-0156-10-D~~S~~E-1K*

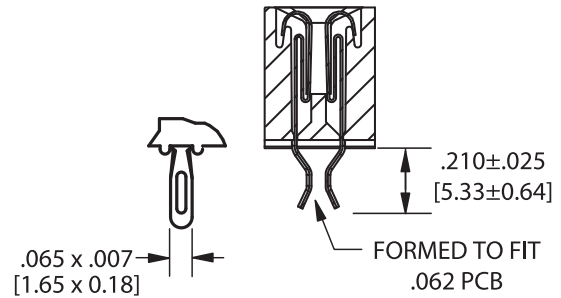

**ECONOMY EYELET  
CARD EXTENDER (PE)**

*Example P/N: EM~~P~~L-0156-10-D~~P~~E-1K*

**MOUNTING STYLE**

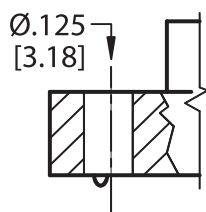

**(STYLE 1)**

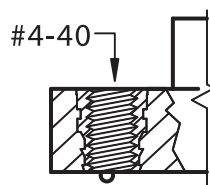

**(STYLE 2)**

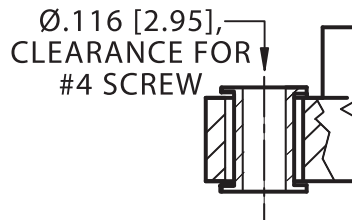

**(STYLE 3)**



**(STYLE 4)**



**.156" [3.96 mm] Contact Centers, .431" [10.95 mm] Insulator Height, Card Extender**

**PART NUMBER OPTIONS**

**MPSL - 0 156 - 10 - D SE - 1 K**

**PLATING - RoHS Compliant**

All Platings are Lead Free and have .000050" Nickel Underplate

**Contact Surface Termination**

\*MPSL = .000010" Gold .000100" Pure Tin Matte

\*MPL = .000100" Overall Pure Tin, Matte

MP = .000010" Overall Gold

**Platings that start with 'E' are for Economy Eyelet Only**

\*EMPSL = .000010" Gold .000100" Pure Tin Matte

\*EMPL = .000100" Overall Pure Tin, Matte

EMP = .000010" Overall Gold

**\* Requires 'K' Modification Code**

Other Plating and thicknesses available upon request

**INSULATOR MATERIAL\*\***

0 = PBT

**CONTACT CENTERS**

156 = .156" [3.96mm]

**NUMBER OF POSITIONS**

Contacts Per Row (See Position Chart Below)

**PLATING MODIFICATION CODE\*\***

K = Required on MPSL or MPL Plating

Omit for MP Plating (Overall Gold)

**MOUNTING STYLE (See Opposite Page)**

1 = .125" Clearance Hole

2 = #4-40 Threaded Insert

3 = Floating Bobbin

4 = No Mounting

**TERMINATION TYPE (See Opposite Page)**

SE = Card Extender

Requires Part Number to start with 'M'

PE = Economy Eyelet Card Extender

Requires Part Number to start with 'E'

**READOUT**

D = Dual

**\*\* See Pages 160-161 for Specifications and other Variations**

**DIMENSIONS** Dimensions in [ ] are in millimeters, all others are in inches.

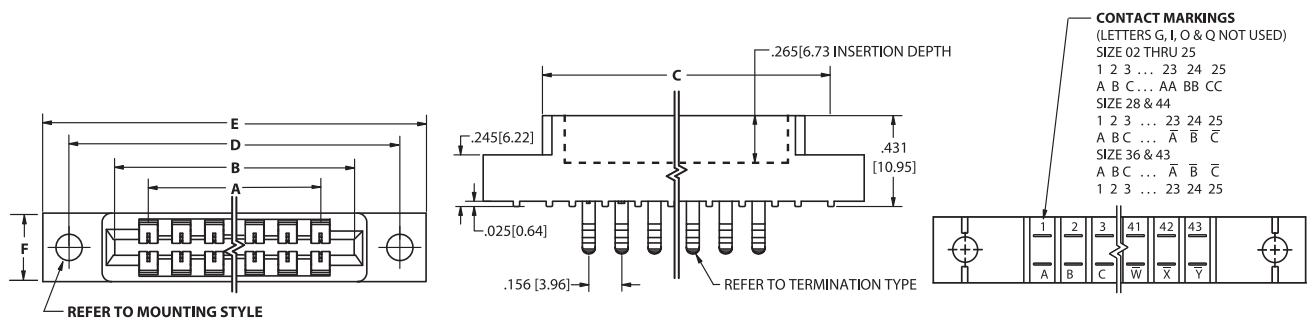

POSITIONS/ CONTACTS	INCHES						[MILLIMETERS]					
	A±.008	B±.008	C±.015	D±.010	E MAX	F±.005	A±0.20	B±0.20	C±0.38	D±0.25	E MAX	F±0.13
02/04	0.156	0.476	0.596	'N' MOUNTING		0.325	3.96	12.09	15.14	'N' MOUNTING		
03/06	0.312	0.632	0.752	'N' MOUNTING			7.92	16.05	19.10	'N' MOUNTING		
06/12	0.780	1.100	1.220	1.533	1.902		19.81	27.94	30.99	38.94	48.31	8.26
08/16	1.092	1.412	1.532	1.845	2.214		27.74	35.86	38.91	46.86	56.24	
10/20	1.404	1.724	1.844	2.157	2.526		35.66	43.79	46.84	54.79	64.16	
11/22	1.560	1.880	2.000	2.313	2.682		39.62	47.75	50.80	58.75	68.12	
12/24	1.716	2.036	2.156	2.469	2.838		43.59	51.71	54.76	62.71	72.09	
15/30	2.184	2.504	2.624	2.937	3.306		55.47	63.60	66.65	74.60	83.97	
18/36	2.652	2.972	3.092	3.405	3.774		67.36	75.49	78.54	86.49	95.86	
22/44	3.276	3.596	3.716	4.029	4.398		83.21	91.34	94.39	102.34	111.71	
24/48	3.588	3.908	4.028	4.341	4.710	91.14	99.26	102.31	110.26	119.63		
25/50	3.744	4.064	4.184	4.497	4.866	95.10	103.23	106.27	114.22	123.60		
28/56	4.212	4.532	4.652	4.965	5.334	106.98	115.11	118.16	126.11	135.48	11.13	
36/72	5.460	5.780	5.900	6.213	6.582	138.68	146.81	149.86	157.81	167.18		
43/86	6.552	6.872	6.992	7.305	7.674	0.500	166.42	174.55	177.60	185.55	194.92	12.70
44/88	6.708	7.028	7.148	7.461	7.830		170.38	178.51	181.56	189.51	198.88	



**.156" [3.96 mm] Contact Centers, .431" [10.95 mm] Insulator Height, Eyelet**

**SPECIFICATIONS**

- Accommodates .062" ± .008" [1.57 ± 0.20] PC Board
- Insulator Material available in PBT, PPS or PA9T
- 3 Amp Current Rating
- Insulator / Contact Specifications and Part Number Options See opposite page
- P/N 04-0003-000 for In Between Contact Polarizing Key
- P/N 04-0002-000 for In Contact Polarizing Key
- See Page 204 (Sold Separately)
- Molded-in Key Available - Consult Factory

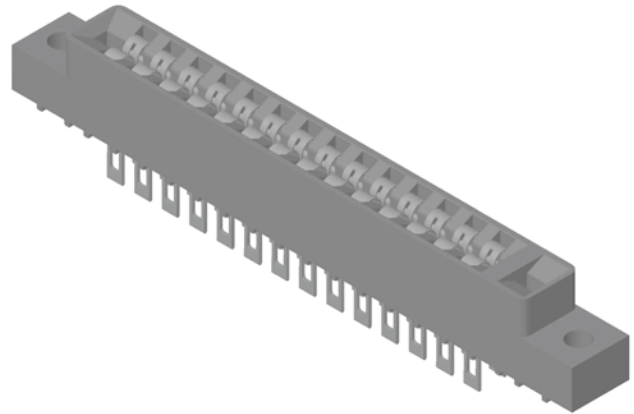

**TERMINATION TYPE**

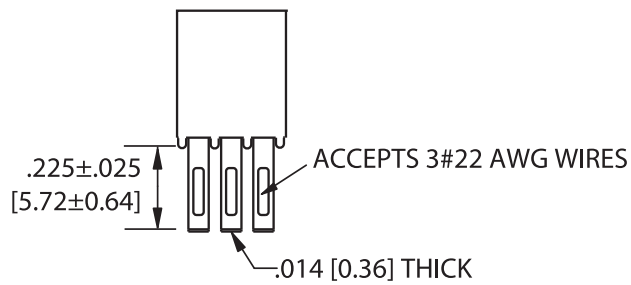

**EYELET (P)**

*Example P/N: MP-0156-10-DP-1*

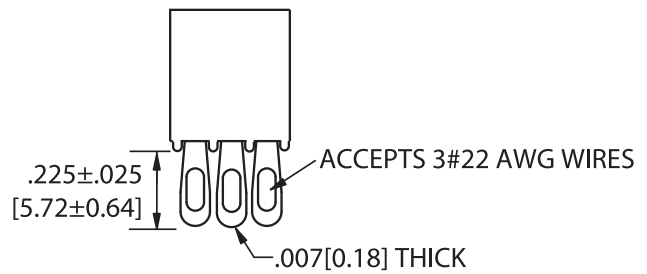

**ECONOMY EYELET (P)**

*Example P/N: EMPSL-0156-10-DP-1K*

**MOUNTING STYLE**

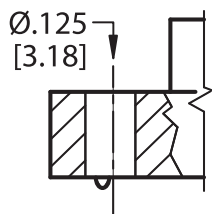

**(STYLE 1)**

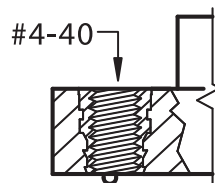

**(STYLE 2)**



**(STYLE 3)**



**(STYLE 4)**



**.156" [3.96 mm] Contact Centers, .431" [10.95 mm] Insulator Height, Eyelet**

**PART NUMBER OPTIONS**

**MPL - 0 156 - 10 - D P - 1 K**

**PLATING - RoHS Compliant**

All Platings are Lead Free and have .000050" Nickel Underplate

**Contact Surface Termination**

- \*MPL = .000100" Overall Pure Tin, Matte
- MP = .000010" Overall Gold

**Platings that start with 'E' are for Economy Eyelet Only**

- \*EMPSL = .000010" Gold .000100" Pure Tin Matte
- \*EMPL = .000100" Overall Pure Tin, Matte
- EMP = .000010" Overall Gold

**\* Requires 'K' Modification Code**

Other Plating and thicknesses available upon request

**INSULATOR MATERIAL\*\***

- 0 = PBT

**CONTACT CENTERS**

- 156 = .156" [3.96mm]

**NUMBER OF POSITIONS**

Contacts Per Row (See Position Chart Below)

**PLATING MODIFICATION CODE\*\***

- K = Required on Tin Plating Terminations
- Omit for MP and EMP Plating (Overall Gold)

**MOUNTING STYLE** (See Opposite Page)

- 1 = .125" Clearance Hole
- 2 = #4-40 Threaded Insert
- 3 = Floating Bobbin
- 4 = No Mounting

**TERMINATION TYPE** (See Opposite Page)

- P = Pierced Eyelet, .014" Thick

**MPL and MP Plating Only**

- P = Economy Eyelet, .007" Thick

**Requires Part Number to start with 'E'**

**READOUT**

- D = Dual

**\*\* See Pages 160-161 for Specifications and other Variations**

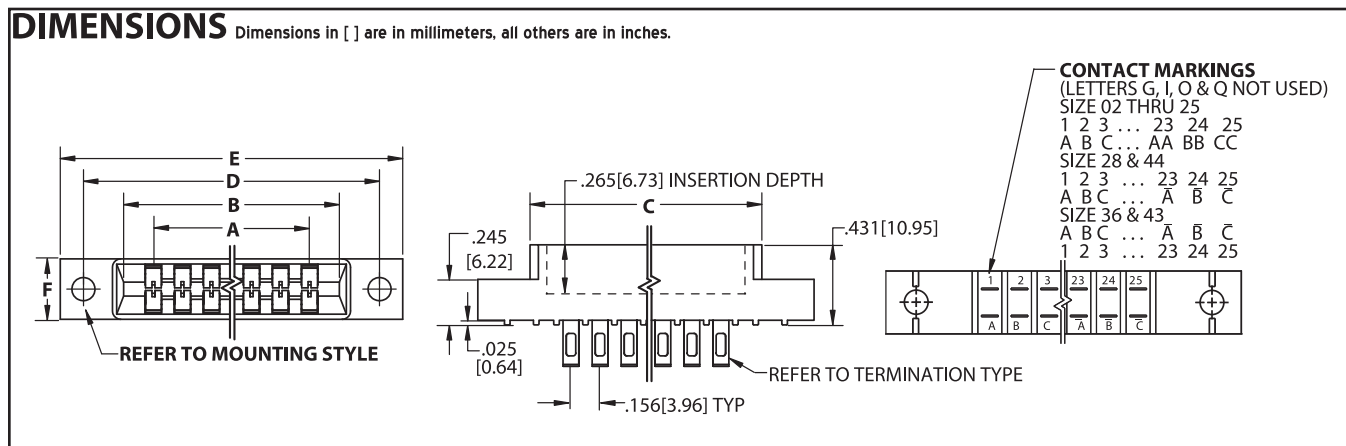

POSITIONS/ CONTACTS	INCHES					[MILLIMETERS]						
	A±.008	B±.008	C±.015	D±.010	E MAX	F±.005	A±0.20	B±0.20	C±0.38	D±0.25	E MAX	F±0.13
02/04	0.156	0.476	0.596	'N' MOUNTING		0.325	3.96	12.09	15.14	'N' MOUNTING		
03/06	0.312	0.632	0.752	'N' MOUNTING			7.92	16.05	19.10	'N' MOUNTING		
06/12	0.780	1.100	1.220	1.533	1.902		19.81	27.94	30.99	38.94	48.31	
08/16	1.092	1.412	1.532	1.845	2.214		27.74	35.86	38.91	46.86	56.24	
10/20	1.404	1.724	1.844	2.157	2.526		35.66	43.79	46.84	54.79	64.16	
11/22	1.560	1.880	2.000	2.313	2.682		39.62	47.75	50.80	58.75	68.12	
12/24	1.716	2.036	2.156	2.469	2.838		43.59	51.71	54.76	62.71	72.09	
15/30	2.184	2.504	2.624	2.937	3.306		55.47	63.60	66.65	74.60	83.97	
18/36	2.652	2.972	3.092	3.405	3.774		67.36	75.49	78.54	86.49	95.86	
22/44	3.276	3.596	3.716	4.029	4.398		83.21	91.34	94.39	102.34	111.71	
24/48	3.588	3.908	4.028	4.341	4.710	91.14	99.26	102.31	110.26	119.63		
25/50	3.744	4.064	4.184	4.497	4.866	95.10	103.23	106.27	114.22	123.60		
28/56	4.212	4.532	4.652	4.965	5.334	106.98	115.11	118.16	126.11	135.48		
36/72	5.460	5.780	5.900	6.213	6.582	138.68	146.81	149.86	157.81	167.18		
43/86	6.552	6.872	6.992	7.305	7.674	0.500	166.42	174.55	177.60	185.55	194.92	
44/88	6.708	7.028	7.148	7.461	7.830		170.38	178.51	181.56	189.51	198.88	



**.156" [3.96 mm] Contact Centers, .610" [15.49 mm] Insulator Height,  
Wire Wrap & Dip Solder**

**SPECIFICATIONS**

- Accommodates .062" ± .008" [1.57 ± 0.20] PC Board
- Insulator Material available in PBT, PPS or PA9T
- 3 Amp Current Rating
- Insulator / Contact Specifications and Part Number Options See opposite page
- P/N 04-0004-000 for In Between Contact Polarizing Key See Page 204 (Sold Separately)
- Molded-in Key Available - Consult Factory

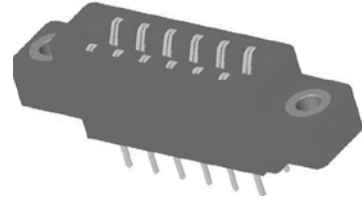

**TERMINATION TYPE**

**LOOP BELLOWS**

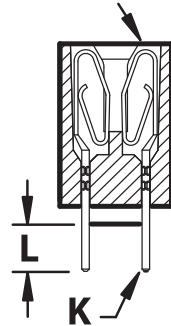

**LOOP BELLOWS**

TERMINATION CODE	MODIFICATION CODE	TYPE	POST CROSS SECTION K	POST LENGTH L	FITS MIN. HOLE SIZE	EXAMPLE PART NUMBER
R	H	Dip Solder	.025 [0.64] Round	.190 [4.83]	.033 [0.84]	<i>MPSL-0156-10-DR-1HK</i>
R	H(.165)	Dip Solder	.025 [0.64] Round	.165 [4.19]	.033 [0.84]	<i>MPSL-0156-10-DR-1HK(.165)</i>
W	H	Dip Solder	.025 [0.64] Square	.190 [4.83]	.040 [1.02]	<i>MPSL-0156-10-DW-1HK</i>
W	OMIT	Wire Wrap	.025 [0.64] Square	.560 [14.20]	.040 [1.02]	<i>MPSL-0156-10-DW-1K</i>

**MOUNTING STYLE**

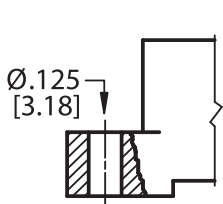

(STYLE 1)

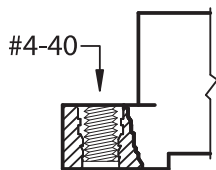

(STYLE 2)



(STYLE 4)

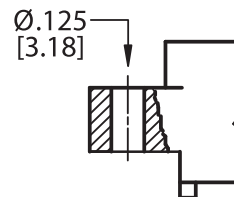

(STYLE 5)

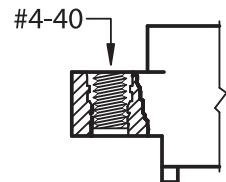

(STYLE 6)

Micro Plastics



**PART NUMBER OPTIONS**

**MPSL - 0 156 - 10 - D W - 1 H K**

**PLATING - RoHS Compliant**

All Platings are Lead Free and have .000050" Nickel Underplate

**Contact Surface Termination**

- \*MPSL = .000010" Gold .000100" Pure Tin, Matte
- \*MPL = .000100" Overall Pure Tin, Matte
- MP = .000010" Overall Gold

**\*Requires 'K' Modification Code**

**INSULATOR MATERIAL\*\***

0 = PBT

**CONTACT CENTERS**

156 = .156" [3.96mm]

**NUMBER OF POSITIONS**

Contacts Per Row (See Position Chart Below)

**READOUT**

D = Dual

**PLATING MODIFICATION CODE\*\***

K = Required on MPSL or MPL Plating  
Omit for MP Plating (Overall Gold)

**MODIFICATION CODE\*\***

(See Opposite Page)

H = Dip Solder .190[4.83] Tail Length  
(.025 Round or .025 Square)

H(.165) = Dip Solder .165[4.19] Tail Length  
(.025 Round Only)

**MOUNTING STYLE** (See Opposite Page)

- 1 = .125" Clearance Hole
- 2 = #4-40 Threaded Insert
- 4 = No Mounting
- 5 = Raised, .125" Clearance Hole
- 6 = Raised, #4-40 Threaded Insert

**TERMINATION TYPE** (See Opposite Page)

**LOOP BELLOWS**

R = .025[.64mm] Round

W = .025[.64mm] Square

**\*\* See Pages 160-161 for Specifications and other Variations**

**DIMENSIONS**

Dimensions in [ ] are in millimeters, all others are in inches.

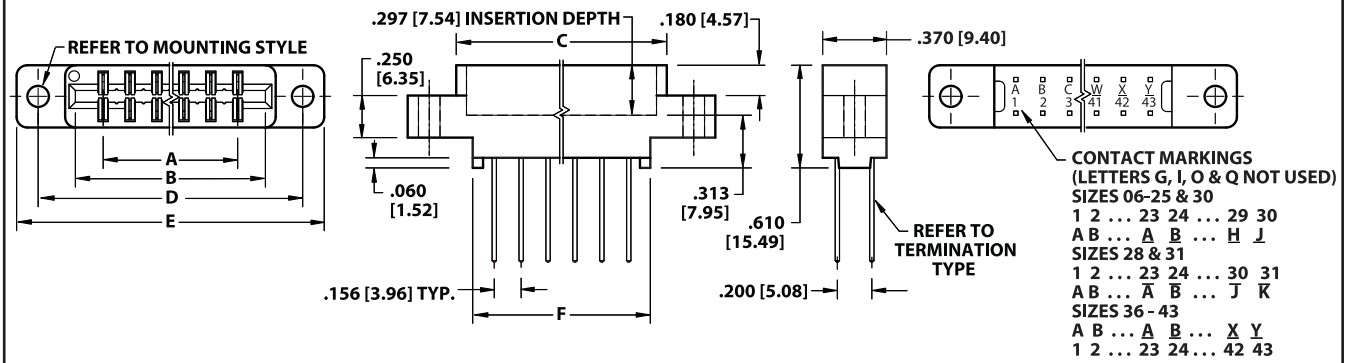

POSITIONS/ CONTACTS	INCHES						[MILLIMETERS]					
	A±.008	B±.008	C±.015	D±.010	E±.020	F±.015	A±0.20	B±0.20	C±0.38	D±0.25	E±0.51	F±0.38
06/12	0.780	1.102	1.221	1.534	1.784	1.030	19.81	27.99	31.01	38.96	45.31	26.16
08/16	1.092	1.414	1.533	1.846	2.096	1.342	27.74	35.92	38.94	46.89	53.24	34.09
10/20	1.404	1.726	1.845	2.158	2.408	1.654	35.66	43.84	46.86	54.81	61.16	42.01
12/24	1.716	2.038	2.157	2.470	2.720	1.966	43.59	51.77	54.79	62.74	69.09	49.94
15/30	2.184	2.506	2.625	2.938	3.188	2.434	55.47	63.65	66.68	74.63	80.98	61.82
18/36	2.652	2.974	3.093	3.406	3.656	2.902	67.36	75.54	78.56	86.51	92.86	73.71
20/40*	2.964	3.286	3.405	3.718	3.968	3.214	75.29	83.46	86.49	94.44	100.79	81.64
22/44	3.276	3.598	3.717	4.030	4.280	3.526	83.21	91.39	94.41	102.36	108.71	89.56
24/48	3.588	3.910	4.029	4.342	4.592	3.838	91.14	99.31	102.34	110.29	116.64	97.49
25/50	3.744	4.066	4.185	4.498	4.748	3.994	95.10	103.28	106.30	114.25	120.60	101.45
28/56	4.212	4.534	4.653	4.966	5.216	4.462	106.98	115.16	118.19	126.14	132.49	113.33
30/60	4.524	4.846	4.965	5.278	5.528	4.774	114.91	123.09	126.11	134.06	140.41	121.26
31/62	4.680	5.002	5.121	5.434	5.684	4.930	118.87	127.05	130.07	138.02	144.37	125.22
36/72	5.460	5.782	5.901	6.214	6.464	5.710	138.68	146.86	149.89	157.84	164.19	145.03
40/80	6.084	6.406	6.525	6.838	7.088	6.334	154.53	162.71	165.74	173.69	180.04	160.88
43/86	6.552	6.874	6.993	7.306	7.556	6.802	166.42	174.60	177.62	185.57	191.92	172.77

\* Consult Factory for availability.



**.156" [3.96 mm] Contact Centers, .550" [13.97 mm] Insulator Height,  
.025" [.64 mm] Square Card Extender**

**SPECIFICATIONS**

- Accommodates .062" ± .008" [1.57 ± 0.20] PC Board
- Insulator Material available in PBT, PPS or PA9T
- 3 Amp Current Rating
- Insulator / Contact Specifications and Part Number Options See opposite page
- P/N 04-0004-000 for In Between Contact Polarizing Key See Page 204 (Sold Separately)
- Molded-in Key Available - Consult Factory

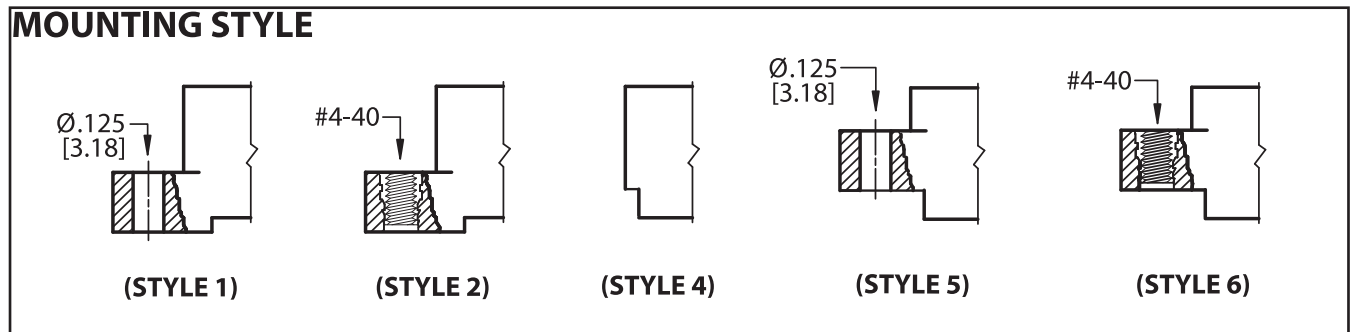
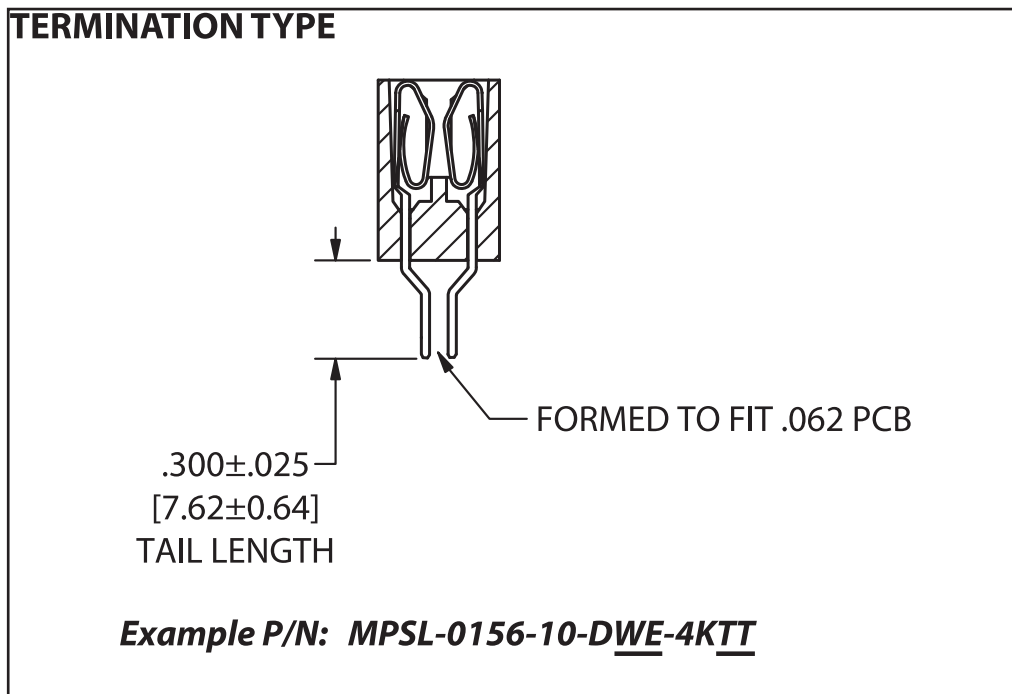
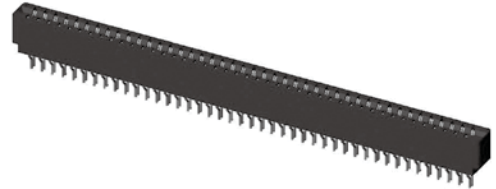

Micro Plastics



**.156" [3.96 mm] Contact Centers, .550" [13.97 mm] Insulator Height, .025" [0.64 mm] Square Card Extender**

**PART NUMBER OPTIONS**

**MPSL - 0 156 - 10 - D WE - 4 K TT**

**PLATING - RoHS Compliant**  
All Platings are Lead Free and have .000050" Nickel Underplate

<b>Contact Surface</b>	<b>Termination</b>
*MPSL = .000010" Gold	.000100" Pure Tin, Matte
*MPL = .000100" Overall Pure Tin, Matte	
MP = .000010" Overall Gold	

\*Requires 'K' Modification Code

**INSULATOR MATERIAL\*\***  
0 = PBT

**CONTACT CENTERS**  
156 = .156" [3.96mm]

**NUMBER OF POSITIONS**  
Contacts Per Row (See Position Chart Below)

**MODIFICATION CODE\*\***  
TT = No Standoffs

**PLATING MODIFICATION CODE\*\***  
K = Required on MPSL or MPL Plating  
Omit for MP Plating (Overall Gold)

**MOUNTING STYLE** (See Opposite Page)  
1 = .125" Clearance Hole  
2 = #4-40 Threaded Insert  
4 = No Mounting  
5 = Raised, .125" Clearance Hole  
6 = Raised, #4-40 Threaded Insert

**TERMINATION TYPE** (See Opposite Page)  
WE = Card Extender

**READOUT**  
D = Dual

**\*\* See Pages 160-161 for Specifications and other Variations**

**DIMENSIONS** Dimensions in [ ] are in millimeters, all others are in inches.

REFER TO MOUNTING STYLE

.370 [9.40]

.250 [6.35]

.120 [3.05]

.156 [3.96]

.025 [0.64]

.297 [7.54] INSERTION DEPTH

.550 [13.97]

CONTACT MARKINGS  
(LETTERS G, I, O & Q NOT USE)  
SIZES 06-25 & 30  
1 2 ... 23 24 ... 29 30  
A B ... A B ... H J  
SIZES 28 & 31  
1 2 ... 23 24 ... 30 31  
A B ... A B ... J K  
SIZES 36-43  
A B ... A B ... X Y  
1 2 ... 23 24 ... 42 43

POSITIONS/ CONTACTS	INCHES						[MILLIMETERS]					
	A±.008	B±.008	C±.015	D±.010	E±.020	F±.015	A±0.20	B±0.20	C±0.38	D±0.25	E±0.51	F±0.38
06/12	0.780	1.102	1.221	1.534	1.784	1.030	19.81	27.99	31.01	38.96	45.31	26.16
08/16	1.092	1.414	1.533	1.846	2.096	1.342	27.74	35.92	38.94	46.89	53.24	34.09
10/20	1.404	1.726	1.845	2.158	2.408	1.654	35.66	43.84	46.86	54.81	61.16	42.01
12/24	1.716	2.038	2.157	2.470	2.720	1.966	43.59	51.77	54.79	62.74	69.09	49.94
15/30	2.184	2.506	2.625	2.938	3.188	2.434	55.47	63.65	66.68	74.63	80.98	61.82
18/36	2.652	2.974	3.093	3.406	3.656	2.902	67.36	75.54	78.56	86.51	92.86	73.71
20/40*	2.964	3.286	3.405	3.718	3.968	3.214	75.29	83.46	86.49	94.44	100.79	81.64
22/44	3.276	3.598	3.717	4.030	4.280	3.526	83.21	91.39	94.41	102.36	108.71	89.56
24/48	3.588	3.910	4.029	4.342	4.592	3.838	91.14	99.31	102.34	110.29	116.64	97.49
25/50	3.744	4.066	4.185	4.498	4.748	3.994	95.10	103.28	106.30	114.25	120.60	101.45
28/56	4.212	4.534	4.653	4.966	5.216	4.462	106.98	115.16	118.19	126.14	132.49	113.33
30/60	4.524	4.846	4.965	5.278	5.528	4.774	114.91	123.09	126.11	134.06	140.41	121.26
31/62	4.680	5.002	5.121	5.434	5.684	4.930	118.87	127.05	130.07	138.02	144.37	125.22
36/72	5.460	5.782	5.901	6.214	6.464	5.710	138.68	146.86	149.89	157.84	164.19	145.03
40/80	6.084	6.406	6.525	6.838	7.088	6.334	154.53	162.71	165.74	173.69	180.04	160.88
43/86	6.552	6.874	6.993	7.306	7.556	6.802	166.42	174.60	177.62	185.57	191.92	172.77

\* Consult Factory for availability.



**.156" [3.96 mm] Contact Centers, .610" [15.49 mm] Insulator Height, Right Angle**

**SPECIFICATIONS**

- Accommodates .062" ± .008" [1.57 ± 0.20] PC Board
- Insulator Material available in PBT, PPS or PA9T
- 3 Amp Current Rating
- Insulator / Contact Specifications and Part Number Options See opposite page
- P/N 04-0004-000 for In Between Contact Polarizing Key See Page 204 (Sold Separately)
- Molded-in Key Available - Consult Factory

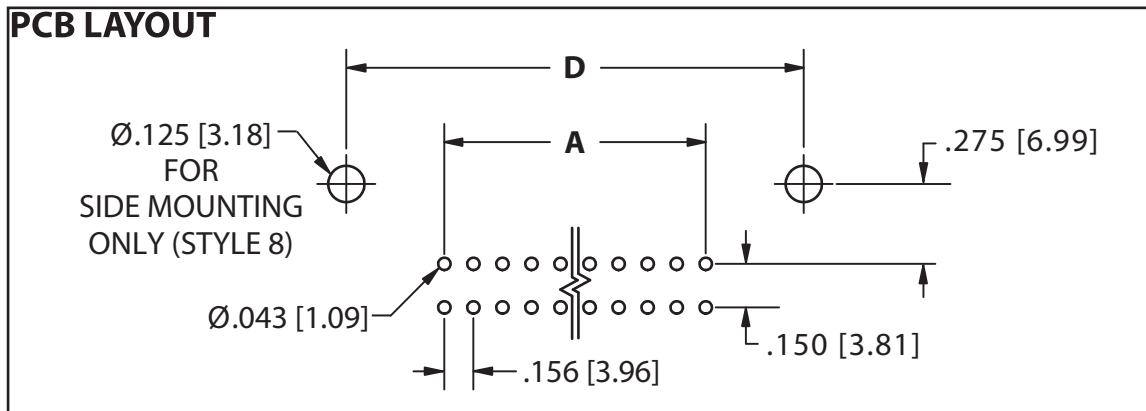
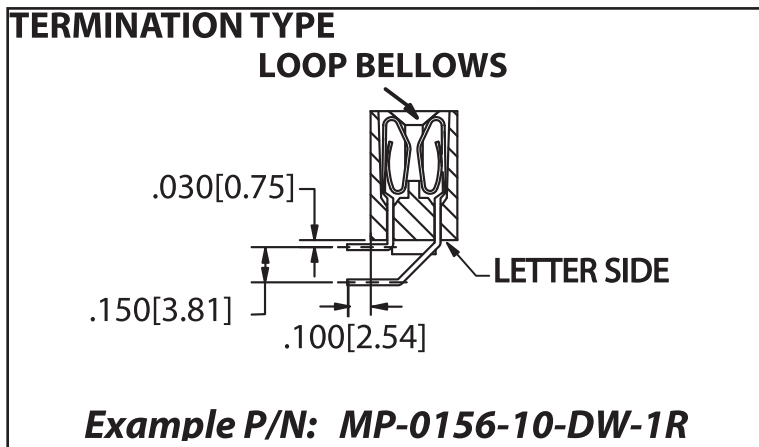
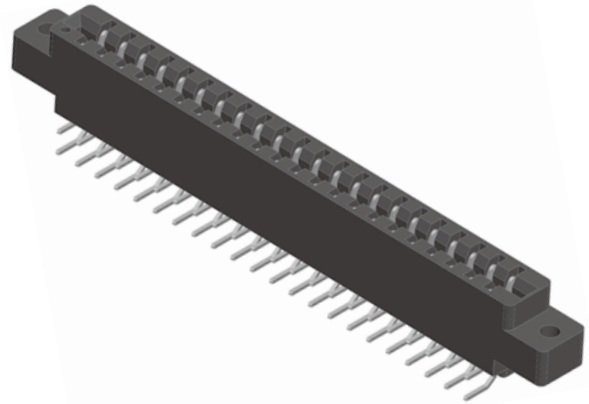

**MOUNTING STYLE**

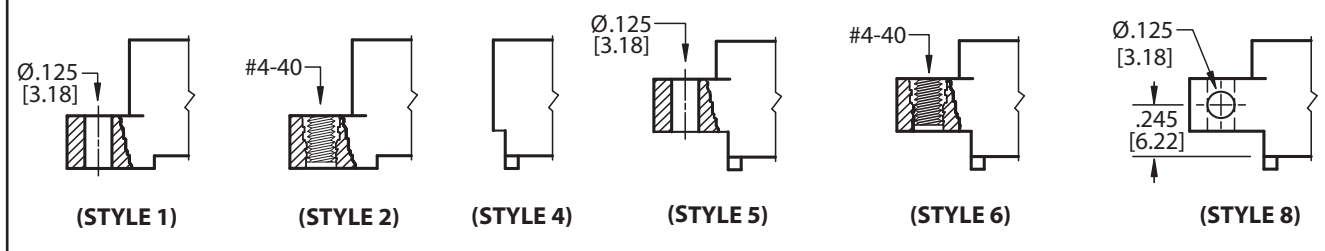

Micro Plastics



**.156" [3.96 mm] Contact Centers, .610" [15.49 mm] Insulator Height, Right Angle**

**PART NUMBER OPTIONS**

**MPSL - 0 156 - 10 - D W - 1 K R**

**PLATING - RoHS Compliant**

All Platings are Lead Free and have .000050" Nickel Underplate

**Contact Surface Termination**

- \*MPSL = .000010" Gold .000100" Pure Tin, Matte
- \*MPL = .000100" Overall Pure Tin, Matte
- MP = .000010" Overall Gold

\*Requires 'K' Modification Code

**INSULATOR MATERIAL\*\***

0 = PBT

**CONTACT CENTERS**

156 = .156" [3.96mm]

**NUMBER OF POSITIONS**

Contacts Per Row (See Position Chart Below)

**READOUT**

D = Dual

**MODIFICATION CODE\*\***

R = Right Angle

**PLATING MODIFICATION CODE\*\***

K = Required on MPSL or MPL Plating  
Omit for MP Plating (Overall Gold)

**MOUNTING STYLE (See Opposite Page)**

- 1 = .125" Clearance Hole
- 2 = #4-40 Threaded Insert
- 4 = No Mounting
- 5 = Raised, .125" Clearance Hole
- 6 = Raised, #4-40 Threaded Insert
- 8 = Raised, Side Mounting, .125" Clearance Hole

**TERMINATION TYPE**

**LOOP BELLOWS**

W = .025 [.64] Square

**\*\* See Pages 160-161 for Specifications and other Variations**

**DIMENSIONS**

Dimensions in [ ] are in millimeters, all others are in inches.

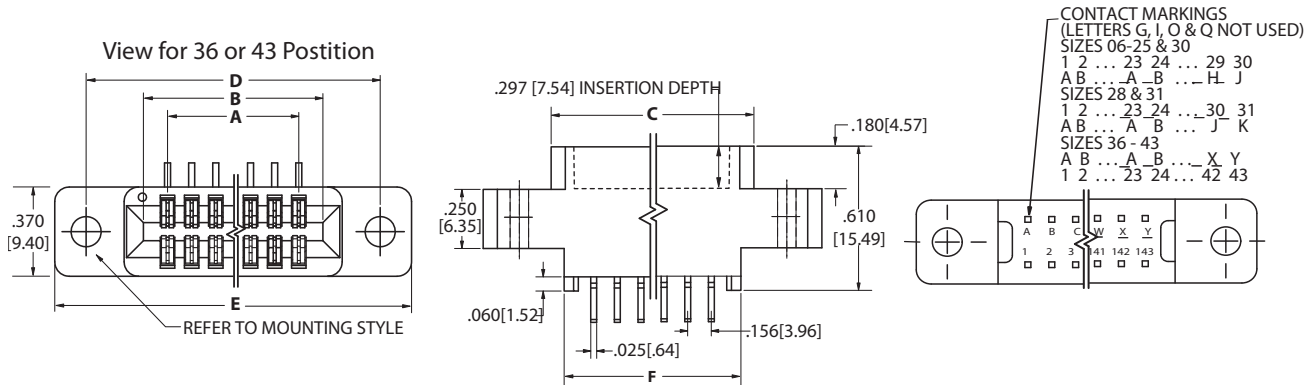

POSITIONS/ CONTACTS	INCHES						[MILLIMETERS]					
	A±.008	B±.008	C±.015	D±.010	E±.020	F±.015	A±0.20	B±0.20	C±0.38	D±0.25	E±0.51	F±0.38
06/12	0.780	1.102	1.221	1.534	1.784	1.030	19.81	27.99	31.01	38.96	45.31	26.16
08/16	1.092	1.414	1.533	1.846	2.096	1.342	27.74	35.92	38.94	46.89	53.24	34.09
10/20	1.404	1.726	1.845	2.158	2.408	1.654	35.66	43.84	46.86	54.81	61.16	42.01
12/24	1.716	2.038	2.157	2.470	2.720	1.966	43.59	51.77	54.79	62.74	69.09	49.94
15/30	2.184	2.506	2.625	2.938	3.188	2.434	55.47	63.65	66.68	74.63	80.98	61.82
18/36	2.652	2.974	3.093	3.406	3.656	2.902	67.36	75.54	78.56	86.51	92.86	73.71
20/40*	2.964	3.286	3.405	3.718	3.968	3.214	75.29	83.46	86.49	94.44	100.79	81.64
22/44	3.276	3.598	3.717	4.030	4.280	3.526	83.21	91.39	94.41	102.36	108.71	89.56
24/48	3.588	3.910	4.029	4.342	4.592	3.838	91.14	99.31	102.34	110.29	116.64	97.49
25/50	3.744	4.066	4.185	4.498	4.748	3.994	95.10	103.28	106.30	114.25	120.60	101.45
28/56	4.212	4.534	4.653	4.966	5.216	4.462	106.98	115.16	118.19	126.14	132.49	113.33
30/60	4.524	4.846	4.965	5.278	5.528	4.774	114.91	123.09	126.11	134.06	140.41	121.26
31/62	4.680	5.002	5.121	5.434	5.684	4.930	118.87	127.05	130.07	138.02	144.37	125.22
36/72	5.460	5.782	5.901	6.214	6.464	5.710	138.68	146.86	149.89	157.84	164.19	145.03
40/80	6.084	6.406	6.525	6.838	7.088	6.334	154.53	162.71	165.74	173.69	180.04	160.88
43/86	6.552	6.874	6.993	7.306	7.556	6.802	166.42	174.60	177.62	185.57	191.92	172.77

\* Consult Factory for availability.



**.156" [3.96 mm] Contact Centers, .720" [18.29 mm] Insulator Height,  
.045" [1.14 mm] Square Wire Wrap**

**SPECIFICATIONS**

- Accommodates .062" ± .008" [1.57 ± 0.20] PC Board
- Insulator Material available in PBT
- 5 Amp Current Rating
- Insulator / Contact Specifications and Part Number Options See opposite page
- Molded-in Key Available - Consult Factory

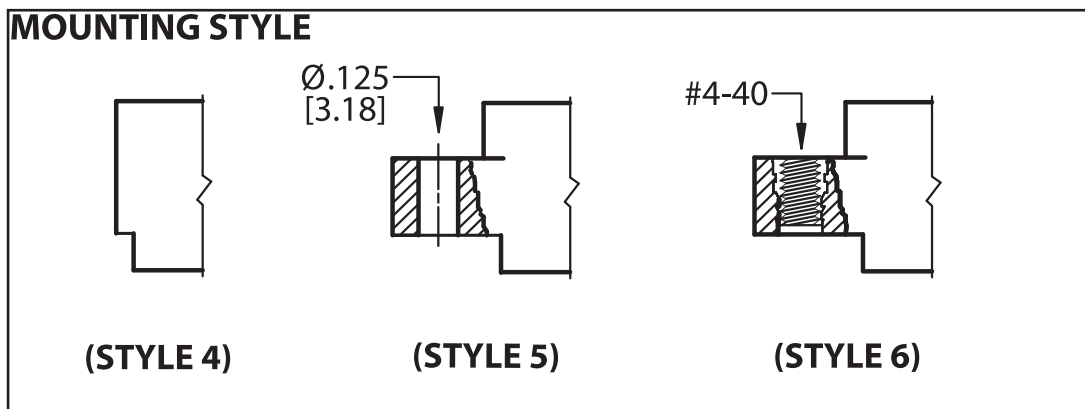
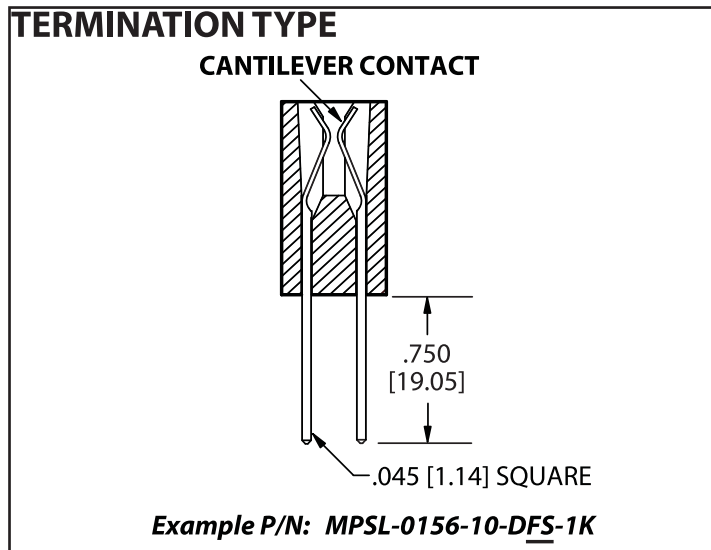
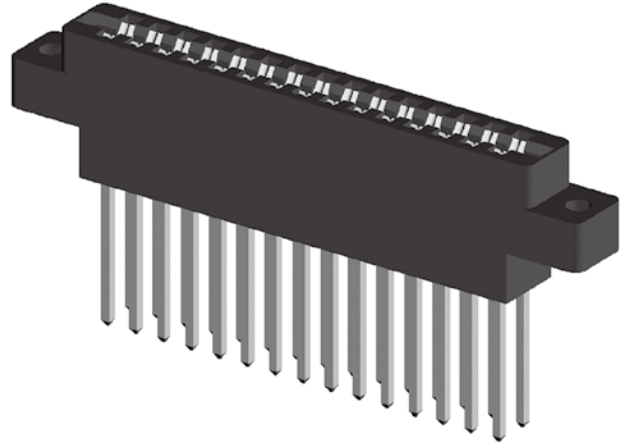

Micro Plastics



**.156" [3.96 mm] Contact Centers, .720" [18.29 mm] Insulator Height, .045" [1.14 mm] Square Wire Wrap**

**PART NUMBER OPTIONS**

**MPSL - 0 156 - 10 - D FS - 4 K**

**PLATING - RoHS Compliant**  
All Platings are Lead Free and have .000050" Nickel Underplate  
**Contact Surface**      **Termination**  
\*MPSL = .000010" Gold      .000100" Pure Tin, Matte  
\*MPL = .000100" Overall Pure Tin, Matte  
MP = .000010" Overall Gold  
**\*Requires 'K' Modification Code**

**INSULATOR MATERIAL\*\***  
0 = PBT

**CONTACT CENTERS**  
156 = .156" [3.96mm]

**NUMBER OF POSITIONS**  
Contacts Per Row (See Position Chart Below)

**MODIFICATION CODE\*\***  
**PLATING MODIFICATION CODE\*\***  
K = Required on MPSL or MPL Plating\*  
Omit for MP Plating (Overall Gold)

**MOUNTING STYLE** (See Opposite Page)  
4 = No Mounting  
5 = Raised, .125" Clearance Hole  
6 = Raised, #4-40 Threaded Insert

**TERMINATION TYPE** (See Opposite Page)  
FS = .045 Square Contacts

**READOUT**  
D = Dual

**\*\* See Pages 160-161 for Specifications and other Variations**

**DIMENSIONS** Dimensions in [ ] are in millimeters, all others are in inches.

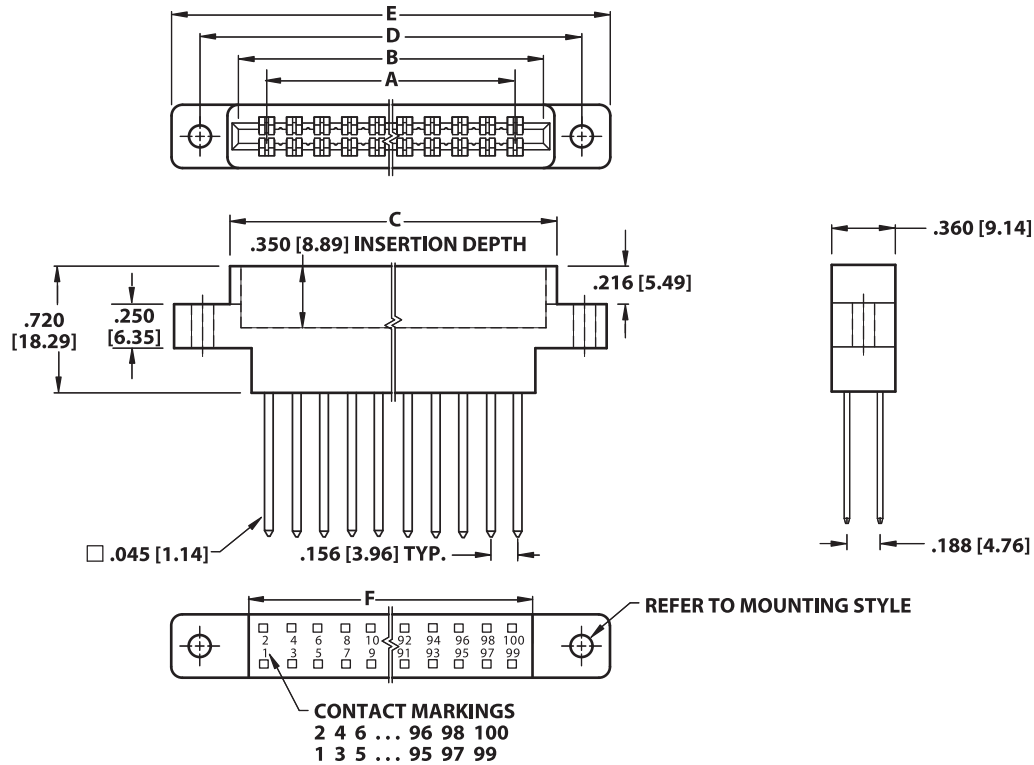

POSITIONS/ CONTACTS	INCHES						[MILLIMETERS]					
	A±.008	B±.008	C±.015	D±.010	E±.020	F±.015	A±0.20	B±0.20	C±0.38	D±0.25	E±0.51	F±0.38
10/20	1.404	1.724	1.848	2.158	2.408	1.604	35.66	43.79	46.94	54.81	61.16	40.74
12/24	1.716	2.036	2.160	2.470	2.720	1.916	43.59	51.71	54.86	62.74	69.09	48.67
15/30	2.184	2.504	2.628	2.938	3.188	2.384	55.47	63.60	66.75	74.63	80.98	60.55
18/36	2.652	2.972	3.096	3.406	3.656	2.852	67.36	75.49	78.64	86.51	92.86	72.44
22/44	3.276	3.596	3.720	4.030	4.280	3.476	83.21	91.34	94.49	102.36	108.71	88.29
25/50	3.744	4.064	4.188	4.498	4.748	3.944	95.10	103.23	106.38	114.25	120.60	100.18
28/56	4.212	4.532	4.656	4.966	5.216	4.412	106.98	115.11	118.26	126.14	132.49	112.06
30/60	4.524	4.844	4.968	5.278	5.528	4.724	114.91	123.04	126.19	134.06	140.41	119.99
36/72	5.460	5.780	5.904	6.214	6.464	5.660	138.68	146.81	149.96	157.84	164.19	143.76
43/86	6.552	6.872	6.996	7.306	7.556	6.752	166.42	174.55	177.70	185.57	191.92	171.50



**Polarizing Keys  
In Between Contact & In Contact**

**ALL KEYS ORDERED SEPARATELY**

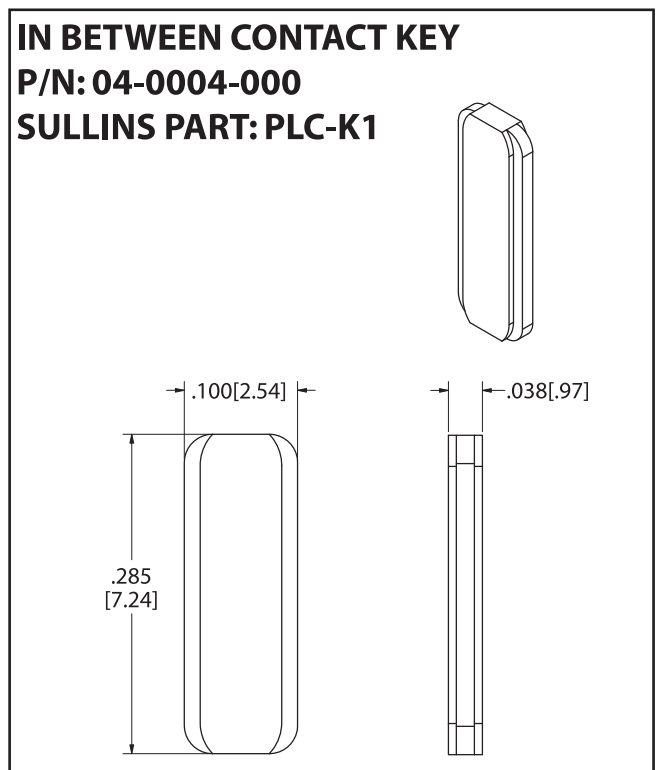
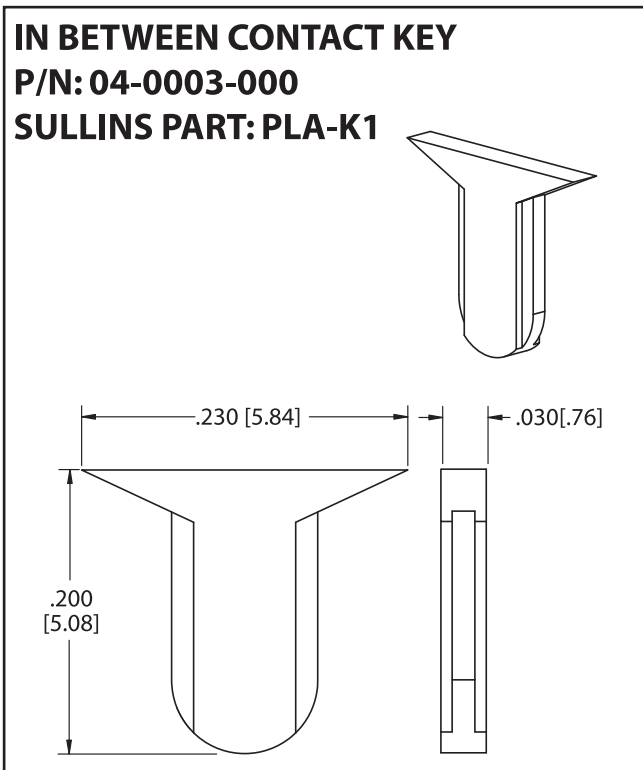
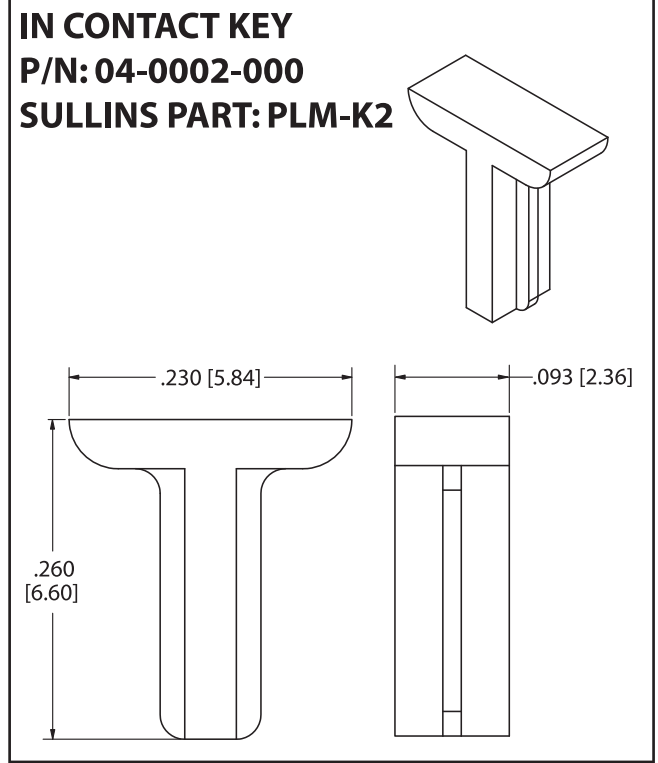
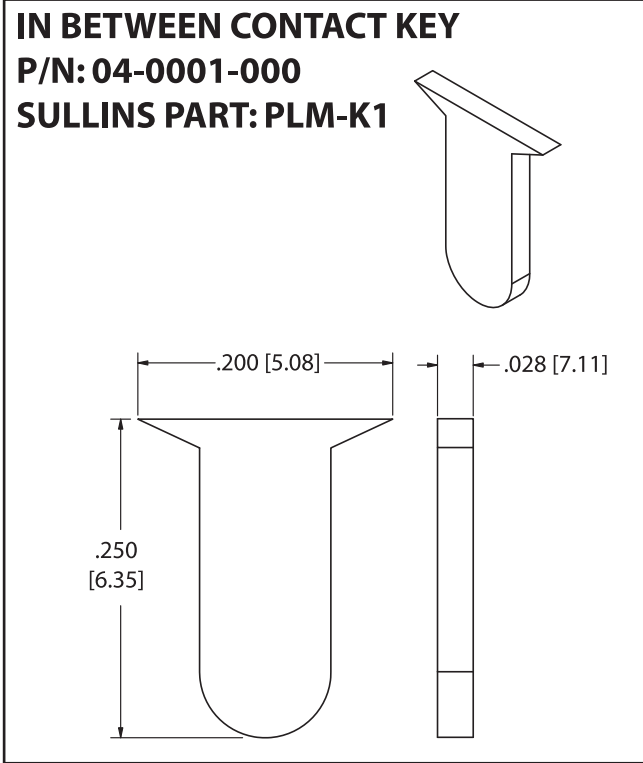

Micro Plastics



**HOW TO LOCATE YOUR P/N:**

Simply use your part number to find the correct pages containing specifications about your connector in this catalog. The underscore sign ( \_ ) is a variable represents design variations in the part number coding.

**EXAMPLE:** to find p/n **EBA10DCAS** go to **A** **DCA** , pages 64-65  
For Micro Plastics P/N's (beginning with EMP or MP) go to last page in index.

**SULLINS CARD EDGE & HEADERS**

PART NUMBER	Page	PART NUMBER	Page	PART NUMBER	Page
__ A __ CA _	64-65	__ B __ DHA _	24-25	__ B91DHF _-S621	26-27
__ A __ CB _	64-65	__ B __ DHB _	24-26	__ B91DHH _-S578	26-27
__ A __ CC _	64-65	__ B __ DHF _	22-23	__ B91DHH _-S621	26-27
__ A __ CK _	64-65	__ B __ DHH _	22-23	__ B91DHL _-S578	26-27
__ A __ DCK _-S288	64-65	__ B __ DHL _	22-23	__ B91DHL _-S621	26-27
__ A __ CM _	64-65	__ B __ DHN _	22-23	__ B91DHN _-S578	26-27
__ A __ DCM _-S288	64-65	__ B __ DHR _	22-23	__ B91DHN _-S621	26-27
__ A __ CS _	64-65			__ B91DHR _-S578	26-27
__ A __ DCS _-S288	64-65	__ B56DHA _-S621	28-29	__ B91DHR _-S621	26-27
__ A __ CT _	64-65	__ B56DHB _-S621	28-29	__ B92DHA _-S250	32-33
__ A __ DCT _-S288	64-65	__ B56DHF _-S578	26-27	__ B92DHA _-S329	32-33
__ A __ CW _	64-65	__ B56DHF _-S621	26-27	__ B92DHB _-S250	32-33
		__ B56DHH _-S578	26-27	__ B92DHB _-S329	32-33
__ A __ RA _	62-63	__ B56DHH _-S621	26-27	__ B92DHF _-S250	30-31
__ A __ RA _-S734	62-63	__ B56DHL _-S578	26-27	__ B92DHF _-S329	30-31
__ A __ RE _	62-63	__ B56DHL _-S621	26-27	__ B92DHF _-S330	30-31
__ A __ DRE _-S13	62-63	__ B56DHN _-S578	26-27	__ B92DHF _-S378	30-31
__ A __ RE _-S734	62-63	__ B56DHN _-S621	26-27	__ B92DHH _-S250	30-31
__ A __ RJ _	62-63	__ B56DHR _-S578	26-27	__ B92DHH _-S329	30-31
__ A __ RJ _-S734	62-63	__ B56DHR _-S621	26-27	__ B92DHH _-S330	30-31
__ A __ RM _	64-65	__ B60DHA _-S621	32-33	__ B92DHH _-S378	30-31
__ A __ RM _-S273	66-67	__ B60DHA _-S793	32-33	__ B92DHL _-S250	30-31
__ A __ DRM _-S288	64-65	__ B60DHB _-S621	32-33	__ B92DHL _-S329	30-31
__ A __ RM _-S664	66-67	__ B60DHB _-S793	32-33	__ B92DHL _-S330	30-31
__ A __ RS _	64-65	__ B60DHF _-S578	30-31	__ B92DHL _-S378	30-31
__ A __ RS _-S273	66-67	__ B60DHF _-S621	30-31		
__ A __ DRS _-S288	64-65	__ B60DHH _-S578	30-31	__ B92DHN _-S250	30-31
__ A __ RS _-S664	66-67	__ B60DHH _-S621	30-31	__ B92DHN _-S329	30-31
__ A __ RT _	62-63			__ B92DHN _-S330	30-31
__ A __ DRT _-S13	62-63	__ B60DHL _-S578	30-31	__ B92DHN _-S378	30-31
__ A __ RT _-S734	62-63	__ B60DHL _-S621	30-31	__ B92DHR _-S250	30-31
__ A __ RX _	62-63	__ B60DHN _-S578	30-31	__ B92DHR _-S329	30-31
__ A __ RX _-S734	62-63	__ B60DHN _-S621	30-31	__ B92DHR _-S330	30-31
__ A __ RY _	62-63	__ B60DHR _-S578	30-31	__ B92DHR _-S378	30-31
__ A __ DRY _-S13	62-63	__ B60DHR _-S621	30-31		
__ A __ RY _-S734	62-63	__ B66DHA _-S621	28-29	__ B106DHA _-S621	28-29
		__ B66DHB _-S621	28-29	__ B106DHB _-S621	28-29
__ A __ TA _	64-65	__ B66DHF _-S578	26-27	__ B106DHF _-S578	26-27
__ A __ TA _-S273	66-67	__ B66DHF _-S621	26-27	__ B106DHF _-S621	26-27
__ A __ TA _-S664	66-67	__ B66DHH _-S578	26-27	__ B106DHH _-S578	26-27
__ A __ TB _	64-65	__ B66DHH _-S621	26-27	__ B106DHH _-S621	26-27
__ A __ TB _-S273	66-67	__ B66DHL _-S578	26-27	__ B106DHL _-S578	26-27
__ A __ TB _-S664	66-67	__ B66DHL _-S621	26-27	__ B106DHL _-S621	26-27
__ A __ TE _	62-63	__ B66DHN _-S578	26-27	__ B106DHN _-S578	26-27
__ A __ TE _-S734	62-63	__ B66DHN _-S621	26-27	__ B106DHN _-S621	26-27
__ A __ TK _	64-65	__ B66DHR _-S578	26-27	__ B106DHR _-S578	26-27
__ A __ DTK _-S288	64-65	__ B66DHR _-S621	26-27	__ B106DHR _-S621	26-27
__ A __ TM _	64-65	__ B91DHA _-S621	28-29	__ B __ DKB _	36-37
__ A __ TM _-S273	66-66	__ B91DHB _-S621	28-29	__ B __ DKB _-S1075	36-37
__ A __ TM _-S664	66-67	__ B91DHF _-S578	26-27	__ B __ DKB _-S1076	36-37



PART NUMBER	Page	PART NUMBER	Page	PART NUMBER	Page
__ B __ DKB __ -S1176	36-37	__ C 0 __ DBEN-M71RC	112-113	__ C __ DFI __	108-109
__ B __ DLR __	34-35	__ C 0 __ DBHN-M71RC	112-113	__ C __ DFJ __	108-109
__ B __ DLT __	34-35	__ C 0 __ DBIN-M71RC	112-113	__ C __ DGA __	108-109
__ B __ DLR __ -S1176	34-35	__ C 0 __ DBJN-M71RC	112-113	__ C __ DGA __ -M71	108-109
__ B __ DLT __ -S1176	34-35		50-51	__ C __ DGB __	108-109
__ B __ DYF __	22-23	__ C __ CA __	50-51	__ C __ DGB __ -M71	108-109
__ B __ DYH __	22-23	__ C __ DCA __ -S189	56-57	__ C __ DGE __	108-109
__ B __ DYR __	22-23	__ C __ CA __ -S371	56-57	__ C __ DGE __ -M71	108-109
__ B __ DYY __	24-25	__ C __ CA __ -S605	58-59	__ C __ DGF __	108-109
		__ C __ DCA __ -S757	50-51	__ C __ DGF __ -M71	108-109
__ C __ DAA __	108-109	__ C __ CB __	50-51		
__ C __ DAB __	108-109	__ C __ DCB __ -S189	56-57	__ C 0 __ DFA __ -RC	110-111
__ C __ DAB __ -M30	108-109	__ C __ CB __ -S371	56-57	__ C 0 __ DFB __ -RC	110-111
__ C __ DAC __	108-109	__ C __ CB __ -S605	50-51	__ C 0 __ DFC __ -RC	110-111
__ C __ DAD __	108-109	__ C __ CC __	50-51	__ C 0 __ DFD __ -RC	110-111
__ C __ DAE __	108-109	__ C __ DCC __ -S189	56-57	__ C 0 __ DFE __ -RC	110-111
__ C __ DAF __	108-109	__ C __ CC __ -S371	56-57	__ C 0 __ DFF __ -RC	110-111
__ C __ DAG __	108-109	__ C __ CC __ -S605	50-51	__ C 0 __ DFG __ -RC	110-111
__ C __ DAH __	108-109	__ C __ CK __	50-51	__ C 0 __ DFH __ -RC	110-111
__ C __ DAI __	108-109	__ C __ DCK __ -S288	50-51	__ C 0 __ DFG __ -RC	110-111
__ C __ DAJ __	108-109	__ C __ CM __	50-51	__ C 0 __ DFI __ -RC	110-111
__ C __ DAK __	108-109	__ C __ DCM __ -S288	56-57	__ C 0 __ DFJ __ -RC	110-111
		__ C __ CM __ -S371	56-57	__ C 0 __ DFO __ -RC	110-111
__ C __ DBA __ -M71	108-109	__ C __ CM __ -S420	50-51	__ C 0 __ DFQ __ -RC	110-111
__ C __ DBB __	108-109	__ C __ DCS __	58-59	__ C 0 __ DFR __ -RC	110-111
__ C __ DBB __ -M71	108-109	__ C __ DCS __ -S36	50-51		
__ C __ DBC __	108-109	__ C __ DCS __ -S288	56-57	__ C __ DJB __	80-81
__ C __ DBC __ -M71	108-109	__ C __ CS __ -S371	56-57	__ C __ DJB __ -S1136	80-81
__ C __ DBD __	108-109	__ C __ CS __ -S420	56-57	__ C __ DJC __	80-81
__ C __ DBD __ -M71	108-109	__ C __ CS __ -S518	56-57	__ C __ DJC __ -S1136	80-81
__ C __ DBE __	108-109	__ C __ CS __ -S524	58-59	__ C __ DJF __	80-81
__ C __ DBE __ -M71	108-109	__ C __ DCS __ -S527	50-51	__ C __ DJF __ -S1136	80-81
__ C __ DBH __	108-109	__ C __ CT __	50-51	__ C __ DJG __	80-81
__ C __ DBH __ -M71	108-109	__ C __ DCT __ -S288	56-57	__ C __ DJG __ -S1136	80-81
__ C __ DBI __	108-109	__ C __ CT __ -S371	56-57	__ C __ DJW __	80-81
__ C __ DBI __ -M71	108-109	__ C __ CT __ -S420	56-57	__ C __ DJW __ -S1136	80-81
__ C __ DBJ __	108-109	__ C __ CT __ -S518	56-57	__ C __ DJX __	80-81
__ C __ DBJ __ -M71	108-109	__ C __ CT __ -S524	50-51	__ C __ DJX __ -S1136	80-81
__ C 0 __ DAAN-RC	110-111	__ C __ CW __	56-57	__ C __ DJY __	80-81
__ C 0 __ DABN-RC	110-111	__ C __ CW __ -S371	56-57	__ C __ DJY __ -S1136	80-81
__ C 0 __ DABN-M30RC	110-111	__ C __ CW __ -S420	56-57	__ C __ DJZ __	80-81
__ C 0 __ DACN-RC	110-111	__ C __ CW __ -S518	56-57	__ C __ DJZ __ -S1136	80-81
__ C 0 __ DADN-RC	110-111	__ C __ CW __ -S524	46-47	__ C __ KA __	50-51
__ C 0 __ DAEN-RC	110-111			__ C __ DKA __ -S189	50-51
__ C 0 __ DAFN-RC	110-111	__ C __ DET __	46-47	__ C __ DKA __ -S1191	52-53
__ C 0 __ DAGN-RC	110-111	__ C __ DEY __	108-109	__ C __ DKA __ -S1243	52-53
__ C 0 __ DAHN-RC	110-111	__ C __ DFA __	108-109	__ C __ KD __	50-51
__ C 0 __ DAIN-RC	110-111	__ C __ DFB __	108-109	__ C __ DKD __ -S1191	52-53
__ C 0 __ DAJN-RC	110-111	__ C __ DFC __	108-109	__ C __ DKD __ -S1243	52-53
__ C 0 __ DAKN-RC	110-111	__ C __ DFD __	108-109	__ C __ KE __	50-51
__ C 0 __ DBAN-M71RC	112-113	__ C __ DFE __	108-109	__ C __ DKE __ -S189	50-51
__ C 0 __ DBBN-M71RC	112-113	__ C __ DFF __	108-109	__ C __ DKE __ -S1191	52-53
__ C 0 __ DBCN-M71RC	112-113	__ C __ DFG __	108-109	__ C __ DKE __ -S1243	52-53
__ C 0 __ DBDN-M71RC	112-113	__ C __ DFH __	108-109	__ C __ KJ __	50-51



PART NUMBER	Page
__ C __ DKJ __-S189	50-51
__ C __ DKJ __-S1191	52-53
__ C __ DKJ __-S1243	52-53
__ C __ KM __	50-51
__ C __ DKM __-S1191	52-53
__ C __ DKM __-S1243	52-53
__ C __ DKN __	50-51
__ C __ DKN __-S1191	52-53
__ C __ DKN __-S1243	52-53
__ C __ DKR __	50-51
__ C __ DKR __-S1191	52-53
__ C __ DKR __-S1243	52-53
__ C __ KS __	50-51
__ C __ DKS __-S1191	50-51
__ C __ DKS __-S1243	52-53
__ C __ KU __	52-53
__ C __ DKU __-S189	50-51
__ C __ DKU __-S1191	52-53
__ C __ DKU __-S1243	52-53
__ C __ DPB __	60-61
__ C __ DPD __	60-61
__ C __ DPE __	60-61
__ C __ DPF __	60-61
__ C __ DPG __	60-61
__ C __ DPJ __	60-61
__ C __ DPM __	60-61
__ C __ DPN __	60-61
__ C __ DPP __	60-61
__ C __ DPR __	60-61
__ C __ DPS __	60-61
__ C __ DPU __	60-61
__ C __ FSL __	40-41
__ C __ RA __	46-47
__ C __ RA __-S93	48-49
__ C __ RA __-S734	46-47
__ C __ RE __	46-47
__ C __ DRE __-S13	46-47
__ C __ RE __-S93	48-49
__ C __ RE __-S734	46-47
__ C __ RM __	50-51
__ C __ RM __-S273	54-55
__ C __ DRM __-S288	50-51
__ C __ RM __-S371	56-57
__ C __ RM __-S420	56-57
__ C __ RM __-S664	54-55
__ C __ RS __	50-51
__ C __ RS __-S273	54-55
__ C __ DRS __-S288	50-51
__ C __ RS __-S371	56-57
__ C __ RS __-S420	56-57
__ C __ RS __-S518	56-57
__ C __ RS __-S524	56-57
__ C __ RS __-S664	54-55
__ C __ RT __	46-47
__ C __ DRT __-S13	46-48
__ C __ RT __-S93	48-49
__ C __ RT __-S734	46-47
__ C __ RX __	46-47
__ C __ RX __-S734	46-47

PART NUMBER	Page
__ C __ RY __	46-47
__ C __ DRY __-S13	46-47
__ C __ RY __-S93	48-49
__ C __ RY __-S734	46-47
__ C __ TA __	50-51
__ C __ DTA __-S189	50-52
__ C __ TA __-S273	54-55
__ C __ TA __-S371	56-57
__ C __ TA __-S605	56-57
__ C __ TA __-S664	54-55
__ C __ TB __	50-51
__ C __ DTB __-S189	50-52
__ C __ TB __-S273	54-55
__ C __ TB __-S371	56-57
__ C __ TB __-S605	56-57
__ C __ TB __-S664	54-55
__ C __ TE __	46-47
__ C __ TE __-S734	46-47
__ C __ TK __	50-51
__ C __ DTK __-S288	50-51
__ C __ TK __-S371	56-57
__ C __ TK __-S420	56-57
__ C __ TK __-S518	56-57
__ C __ TK __-S524	56-57
__ C __ TM __	50-51
__ C __ DTM __-S189	50-52
__ C __ TM __-S273	54-55
__ C __ TM __-S371	56-57
__ C __ TM __-S605	56-57
__ C __ TM __-S664	54-55
__ C __ DZA __	108-109
__ C __ DZB __	108-109
__ C __ DZC __	108-109
__ C __ DZD __	108-109
__ C __ DZI __	108-109
__ C __ DZJ __	108-109
__ C __ DZO __	108-109
__ C __ DZQ __	108-109
__ C __ DZR __	108-109
__ C __ DZS __-M30	108-109
__ C __ DZT __-M30	108-109
__ C 0 __ DZAN-RC	110-111
__ C 0 __ DZBN-RC	110-111
__ C 0 __ DZCN-RC	110-111
__ C 0 __ DZDN-RC	110-111
__ C 0 __ DZIN-RC	110-111
__ C 0 __ DZJN-RC	110-111
__ C 0 __ DZON-RC	110-111
__ C 0 __ DZQN-RC	110-111
__ C 0 __ DZRN-RC	110-111
__ C 0 __ DZSN-M30RC	112-113
__ C 0 __ DZTN-M30RC	112-113
__ C __ MMA __	42-43
__ C __ MMA __-S189	42-43
__ C __ MMB __	42-43
__ C __ MMB __-S189	42-43
__ C __ MMD __	42-43
__ C __ MMD __-S189	42-43
__ C __ MMJ __	42-43

PART NUMBER	Page
__ C __ MMJ __-S189	42-43
__ C __ MMK __	42-43
__ C __ MMK __-S189	42-43
__ C __ MMM __	42-43
__ C __ MMN __	42-43
__ C __ MMR __	42-43
__ C __ MMS __	42-43
__ C __ MMV __	42-43
__ C __ MMV __-S189	42-43
__ C __ MMW __	42-43
__ C __ SAA __	108-109
__ C __ SAB __	108-109
__ C __ SAB __-M30	108-109
__ C __ SAC __	108-109
__ C __ SAD __	108-109
__ C __ SAE __	108-109
__ C __ SAF __	108-109
__ C __ SAG __	108-109
__ C __ SAH __	108-109
__ C __ SAI __	108-109
__ C __ SAJ __	108-109
__ C __ SAK __	108-109
__ C __ SBA __	108-109
__ C __ SBA __-M71	108-109
__ C __ SBB __	108-109
__ C __ SBB __-M71	108-109
__ C __ SBC __	108-109
__ C __ SBC __-M71	108-109
__ C __ SBD __	108-109
__ C __ SBD __-M71	108-109
__ C __ SBE __	108-109
__ C __ SBE __-M71	108-109
__ C __ SBF __	108-109
__ C __ SBF __-M71	108-109
__ C __ SBG __	108-109
__ C __ SBG __-M71	108-109
__ C __ SBH __	108-109
__ C __ SBH __-M71	108-109
__ C __ SBI __	108-109
__ C __ SBI __-M71	108-109
__ C __ SBJ __	108-109
__ C __ SBJ __-M71	108-109
__ C __ SBS __-M89	108-109
__ C __ SDA __	108-109
__ C __ SDA __-M71	108-109
__ C __ SFA __	108-109
__ C __ SFB __	108-109
__ C __ SFB __-M30	108-109
__ C __ SFC __	108-109
__ C __ SFD __	108-109
__ C __ SFE __	108-109
__ C __ SFF __	108-109
__ C __ SFG __	108-109
__ C __ SFH __	108-109
__ C __ SFI __	108-109
__ C __ SFJ __	108-109
__ C __ SGA __	108-109
__ C __ SGA __-M71	108-109
__ C __ SGB __	108-109



PART NUMBER	Page	PART NUMBER	Page	PART NUMBER	Page
__ C __ SGB _-M71	108-109	__ J __ MC _	68-69	__ M __ DR _ -S288	74-75
__ C __ SGC _	108-109	__ J __ SC _	68-69	__ M __ RP _	70-71
__ C __ SGC _-M71	108-109	__ K __ DKB _	38-38	__ M __ RP _-S37, S92	72-73
__ C __ SGD _	108-109	__ K __ DKB _-S107_	38-39	__ M __ RS _	74-75
__ C __ SGD _-M71	108-109	__ M __ CA _	74-75	__ M __ R _ -S273, S664	76-77
__ C __ SGE _	108-109	__ M __ DCA _-S189	74-75	__ M __ RT _	70-71
__ C __ SGE _-M71	108-109	__ M __ CB _	74-75	__ M __ DRT _-S13	70-71
__ C __ SGF _	108-109	__ M __ DCB _-S189	74-75	__ M __ RT _-S37, S92	72-73
__ C __ SGF _-M71	108-109	__ M __ CC _	74-75	__ M __ RU _	70-71
__ C __ SGS _-M89	108-109	__ M __ DCC _-S189	74-75	__ M __ RU _-S37, S92	72-73
__ C __ SZA _	108-109	__ M __ CK _	74-75	__ M __ RX _	70-71
__ C __ SZB _	108-109	__ M __ DCK _-S288	74-75	__ M __ RX _-S37, S92	72-73
__ C __ SZC _	108-109	__ M __ CM _	74-75	__ M __ RY _	70-71
__ C __ SZC _-M89	108-109	__ M __ DCM _-S288	74-75	__ M __ DRY _-S13	70-71
__ C __ SZD _	108-109	__ M __ CS _	74-75	__ M __ RY _-S37, S92	72-73
__ C __ SZI _	108-109	__ M __ DCS _-S288	74-75	__ M __ SA _	70-71
__ C __ SZJ _	108-109	__ M __ CT _	74-75	__ M __ SA _-S37, S92	72-73
__ C __ SZO _	108-109	__ M __ DCT _-S288	74-75	__ M __ SE _	70-71
__ C __ SZQ _	108-109	__ M __ CW _	74-75	__ M __ DSE _-S13	70-71
__ C __ SZR _	108-109	__ M __ DCW _-S288	74-75	__ M __ SE _-S37, S92	72-73
__ C __ SZ _-M30	108-109	EC M __ DJ_N	82-83	__ M __ DSU _	70-71
__ C __ SZU _-M89	108-109	ECM __ DJ_N-S1136	82-83	__ M __ DSU _-S37, S92	72-73
__ C 0 __ SA_N-RC	110-111	__ M __ KA _	74-75	__ M __ DSX _	70-71
__ C 0 __ SABN-M30RC	112-113	__ M __ DKA _-S189	74-75	__ M __ DSX _-S37, S92	72-73
__ C 0 __ SB_N-RC	112-113	__ M __ KD _	74-75	__ M __ TA _	74-75
__ C 0 __ SB_N-M71RC	112-113	__ M __ KE _	74-75	__ M __ DTA _-S189	74-75
__ C 0 __ SBS _-M89RC	112-113	__ M __ DKE _-S189	74-75	__ M __ TA _-S273, S664	76-77
__ C 0 __ SD_N-RC	112-113	__ M __ KJ _	74-75	__ M __ TB _	74-75
__ C 0 __ SD_N-M71RC	112-113	__ M __ DKJ _-S189	74-75	__ M __ DTB _-S189	74-75
__ C 0 __ SF_N-RC	110-111	__ M __ KK _	78-79	__ M __ TB _-S273, S664	76-77
__ C 0 __ SFBN-M30RC	112-113	__ M __ KL _	78-79	__ M __ TK _	74-75
__ C 0 __ SG_N-RC	112-113	__ M __ KM _	74-75	__ M __ DTK _-S288	74-75
__ C 0 __ SG_N-M71RC	112-113	__ M __ DKN _	74-75	__ M __ TM _	74-75
__ C 0 __ SGSN-M89RC	112-113	__ M __ DKR _	74-75	__ M __ DTM _-S189	74-75
__ C 0 __ SZ_N-RC	110-111	__ M __ KS _	74-75	__ M __ TM _-S273, S664	76-77
__ C 0 __ SZCN-M89RC	112-113	__ M __ KU _	74-75	__ M __ WW _	78-79
__ C 0 __ SZ_N-M30RC	112-113	__ M __ DKU _-S189	74-75	__ M __ MMA _	44-45
__ C 0 __ SZUN-M89RC	112-113	__ M __ RA _	70-71	__ M __ MMA _-S189	44-45
__ E __ DHA _	10-11	__ M __ RA _-S37	72-73	__ M __ MMB _	44-45
__ E __ DHAN-T9_10	16-17	__ M __ RA _-S92	72-73	__ M __ MMB _-S189	44-45
__ E __ DHB _	10-11	__ M __ RE _	70-71	__ M __ MMD _	44-45
__ E __ DHF _	8-9	__ M __ RE _-S37	72-73	__ M __ MMD _-S189	44-45
__ E __ DHFN-T951	18-19	__ M __ RE _-S92	72-73	__ M __ MMJ _	44-45
__ E __ DHH _	8-9	__ M __ RF _	70-71	__ M __ MMJ _-S189	44-45
__ E __ DHHN-T9_1	12-13	__ M __ RK _	70-71	__ M __ MMK _	44-45
__ E82DHHN-T9_	20-21	__ M __ DRK _-S13	70-71	__ M __ MMK _-S189	44-45
__ E __ DHR _	8-9	__ M __ RK _-S37, S92	72-73	__ M __ MMM _	44-45
__ E __ DHR _-T941	14-15	__ M __ RM _	74-75	__ M __ MMN _	44-45



PART NUMBER	Page
__ M __ MMR _	44-45
__ M __ MMS _	44-45
__ M __ MMV _	44-45
__ M __ MMV _-S189	44-45
__ M __ MMW _	44-45
GRPB __ 1VW_N-RC	90-91
GRPB __ 2MWCN-RC	90-91
GRPB __ 2VWQ_-RC	90-91
GRPB __ 2VWVN-RC	90-91
LPPB __ 1NFFN-RC	92-93
LPPB __ 1NFSC-RC	92-93
LPPB __ 1NGCN-RC	92-93
LPPB __ 2CFFN-RC	92-93
LPPB __ 2NFSP-RC	92-93
LPPB __ 2NFSS-RC	92-93
_ P _C __ 1LF_N-RC	114-115
_ P _C __ 1LGBN-RC	114-115
_ P _C __ 2LFBN-RC	114-115
_ P _C __ 2LJB _-RC	114-115
NP _C __ 1KFX _-RC	114-115
NP _C __ 2KFM _-RC	114-115
PP _C __ 2LFHN-M __ RC	114-115
NPB02DVFN-RC	122
NPB02SVAN-RC	122
NPB02SVFN-RC	122
NPC02SX_N-RC	124-125
NPN02SX_N-RC	123

PART NUMBER	Page
NPPN __ 1BF_N-RC	102-103
NPPN __ 1FGGN-RC	102-103
NPPN __ 2AF_N-RC	102-103
NPPN __ 2FFK _-RC	102-103
NPPN __ 2FJFN-RC	102-103
NPPN __ 2GFN _-RC	102-103
NPPN __ 4EFCN-RC	100-101
NRPN __ 1PAEN-RC	100-101
NRPN __ 1PARN-RC	100-101
NRPN __ 2MAM _-RC	100-101
NRPN __ 2PAEN-RC	100-101
NRPN __ 2PARN-RC	100-101
NRPN __ 4RCCN-RC	100-101
PLA-K1	204
PLC-K1	205
PLM-K2	206
QPC02 SERIES	112-113
SBH11-NBPC	118
SBH21-NBPN-D __	106
SBH31-NBPN-D __ -RA-BK	96
SBH41-NBPN-D __ -RA-BK	98
SBH51-LPPE	88-89
SDS100 SERIES	138-139
SDS101 SERIES	140-141
SDS103 SERIES	142-143
SDS104 SERIES	144-145
SDS107 SERIES	146-149
SDS108 SERIES	150-151
SDS155 SERIES	152-153
SDS160 SERIES	154-155
SDS223 SERIES	156-157
SDS224 SERIES	158-159

PART NUMBER	Page
SFH11-P __ C	118
SFH21-PP _N	107
SFH210-PP _C	120
SFH213-PP _N	118
SFH31-NP _B	97
SFH41-PP _B	99
SFH413-PP _B	99
SFM210- LP _E	86
SFM230-NPPB	94-95
SFM230-NPPN	104
SFM315- LP _E	86
SFM710	116
SIP110-PP _C	121
SMH1 __ - LP _E	84-85
SPC02	124-125
SPN02	123
SWH201	116
SWH204	120
SWH25X	122
SWR201	118
SWR204	121
SWR25X	123
SWT201	116
SWT204	120
SWT25X	122





Micro Plastics Part Number	Page
04-0001-000	204
04-0002-000	204
04-0003-000	204
04-0004-000	204
EMP- _ 156- _ _ _ -DP- _ _ _	194-195
EMP- _ 156- _ _ _ -DPE- _ _ _	192-193
EMPL- _ 156- _ _ _ -DP- _ K _	194-195
EMPL- _ 156- _ _ _ -DPE- _ K _	192-193
EMPSL- _ 156- _ _ _ -DP- _ K _	194-195
EMPSL- _ 156- _ _ _ -DPE- _ K _	192-193
MP- _ 100- _ _ _ -DP- _ _ _	166-167
MP- _ 100- _ _ _ -DR- _ _ _	168-169
MP- _ 100- _ _ _ -DS- _ _ _	162-163
MP- _ 100- _ _ _ -DS- _ X9 _	162-163
MP- _ 100- _ _ _ -DSE- _ _ _	164-165
MP- _ 100- _ _ _ -DW- _ _ _	168-169
MP- _ 100- _ _ _ -DW- _ R _	172-173
MP- _ 100- _ _ _ -DWE- _ _ _	170-171
MP- _ 100-18/31-DR- _ _ _	174-175
MP- _ 100-18/31-DW- _ _ _	174-175
MP- _ 125- _ _ _ -DP- _ _ _	180-181
MP- _ 125- _ _ _ -DR- _ _ _	182-183
MP- _ 125- _ _ _ -DS- _ _ _	176-177
MP- _ 125- _ _ _ -DS- _ X9 _	176-177
MP- _ 125- _ _ _ -DSE- _ _ _	178-179
MP- _ 125- _ _ _ -DW- _ _ _	182-183
MP- _ 125- _ _ _ -DW- _ R _	186-187
MP- _ 125- _ _ _ -DWE- _ _ _	184-185
MP- _ 150- _ _ _ -DR- _ _ _	188-189
MP- _ 150- _ _ _ -DW- _ _ _	188-189
MP- _ 156- _ _ _ -DFS- _ _ _	202-203
MP- _ 156- _ _ _ -DP- _ _ _	194-195
MP- _ 156- _ _ _ -DR- _ _ _	196-197
MP- _ 156- _ _ _ -DS- _ _ _	190-191
MP- _ 156- _ _ _ -DS- _ X9 _	190-191
MP- _ 156- _ _ _ -DSE- _ _ _	192-193
MP- _ 156- _ _ _ -DW- _ _ _	196-197
MP- _ 156- _ _ _ -DW- _ R _	200-201
MP- _ 156- _ _ _ -DWE- _ _ _	198-199
MPL- _ 100- _ _ _ -DP- _ K _	166-167
MPL- _ 100- _ _ _ -DR- _ K _	168-169
MPL- _ 100- _ _ _ -DS- _ K _	162-163
MPL- _ 100- _ _ _ -DS- _ X9K _	162-163
MPL- _ 100- _ _ _ -DSE- _ K _	164-165
MPL- _ 100- _ _ _ -DW- _ K _	168-169
MPL- _ 100- _ _ _ -DW- _ KR _	172-173
MPL- _ 100- _ _ _ -DWE- _ K _	170-171
MPL- _ 100-18/31-DR- _ K _	174-175
MPL- _ 100-18/31-DW- _ K _	174-175

Micro Plastics Part Number	Page
MPL- _ 125- _ _ _ -DP- _ K _	180-181
MPL- _ 125- _ _ _ -DR- _ K _	182-183
MPL- _ 125- _ _ _ -DS- _ K _	176-177
MPL- _ 125- _ _ _ -DS- _ X9K _	176-177
MPL- _ 125- _ _ _ -DSE- _ K _	178-179
MPL- _ 125- _ _ _ -DW- _ K _	182-183
MPL- _ 125- _ _ _ -DW- _ KR _	186-187
MPL- _ 125- _ _ _ -DWE- _ K _	138-139
MPL- _ 150- _ _ _ -DR- _ K _	188-189
MPL- _ 150- _ _ _ -DW- _ K _	188-189
MPL- _ 156- _ _ _ -DFS- _ K _	202-203
MPL- _ 156- _ _ _ -DP- _ K _	194-195
MPL- _ 156- _ _ _ -DR- _ K _	196-197
MPL- _ 156- _ _ _ -DS- _ K _	190-191
MPL- _ 156- _ _ _ -DS- _ X9K _	190-191
MPL- _ 156- _ _ _ -DSE- _ K _	192-193
MPL- _ 156- _ _ _ -DW- _ K _	196-197
MPL- _ 156- _ _ _ -DW- _ KR _	200-201
MPL- _ 156- _ _ _ -DWE- _ K _	198-199
MPSL- _ 100- _ _ _ -DR- _ K _	168-169
MPSL- _ 100- _ _ _ -DS- _ K _	162-163
MPSL- _ 100- _ _ _ -DS- _ X9K _	162-163
MPSL- _ 100- _ _ _ -DSE- _ K _	164-165
MPSL- _ 100- _ _ _ -DW- _ K _	168-169
MPSL- _ 100- _ _ _ -DW- _ KR _	172-173
MPSL- _ 100- _ _ _ -DWE- _ K _	170-171
MPSL- _ 100-18/31-DR- _ K _	174-175
MPSL- _ 100-18/31-DW- _ K _	174-175
MPSL- _ 125- _ _ _ -DR- _ K _	182-183
MPSL- _ 125- _ _ _ -DS- _ K _	176-177
MPSL- _ 125- _ _ _ -DS- _ X9K _	176-177
MPSL- _ 125- _ _ _ -DSE- _ K _	178-179
MPSL- _ 125- _ _ _ -DW- _ K _	182-183
MPSL- _ 125- _ _ _ -DW- _ KR _	186-187
MPSL- _ 125- _ _ _ -DWE- _ K _	138-139
MPSL- _ 150- _ _ _ -DR- _ K _	188-189
MPSL- _ 150- _ _ _ -DW- _ K _	188-189
MPSL- _ 156- _ _ _ -DFS- _ K _	202-203
MPSL- _ 156- _ _ _ -DR- _ K _	196-197
MPSL- _ 156- _ _ _ -DS- _ X9K _	190-191
MPSL- _ 156- _ _ _ -DS- _ K _	190-191
MPSL- _ 156- _ _ _ -DSE- _ K _	192-193
MPSL- _ 156- _ _ _ -DW- _ K _	196-197
MPSL- _ 156- _ _ _ -DW- _ KR _	200-201
MPSL- _ 156- _ _ _ -DWE- _ K _	198-199



## About Sullins

### Designed for Innovation Since 1971

Sullins Connector Solutions is the leader in developing and delivering reliable, cutting-edge connectors for diverse applications and industries worldwide. Headquartered in San Marcos, California, and privately held, Sullins provides the largest selection of 100% RoHS, UL/CUL approved edgecards and headers in the industry. Our high-level, high-density and high-temperature connectors are specifically designed for mission-critical applications used by leading manufacturers and developers all over the world.

### Micro Plastics, Inc. is Now Sullins

Sullins acquired Micro Plastics, Inc. in 2004 to offer customers a broader range of innovative connectors and customer-driven services.

### Commitment to Quality and Speed

Sullins is committed to using quality, RoHS compliant parts to produce reliable, high quality connectors. Our completely streamlined, in-house manufacturing facility allows us to deliver orders within 5 days or less.\*

### No Order is Too Small

Sullins accommodates all types of orders, large or small. We'll even accept orders as small as 10 connectors.

### Global Sales and Service

Sullins has partnered with a network of strategically located distributors for more efficient international sales and service. Visit us at [www.sullinscorp.com](http://www.sullinscorp.com) or email [info@sullinscorp.com](mailto:info@sullinscorp.com) for more information.

\* While our average delivery time is within five business days, some connector designs with more customized specifications may require additional time to complete.

©2013 Sullins Connector Solutions



Order Samples & Products:  
[www.sullinscorp.com](http://www.sullinscorp.com)  
[info@sullinscorp.com](mailto:info@sullinscorp.com)  
888.774.3100 toll-free

**USA HQ** | 801 E Mission Rd, San Marcos, CA 92069, USA  
+1-760-744-0125 | fax +1-760-744-6081

**Taiwan** | 10F, NO 268, Fuxing S. Rd., Sec. 2, Taipei, Taiwan  
+886-2-2738-7377 | fax +886-2-2738-3586





# SULLINS

CONNECTOR SOLUTIONS

We take the time to understand your application and industry, then help you find the right connector to bring your innovations to life. Even if we have to build it from scratch to your exact specifications. And deliver it faster than our competitors.

Any Application, Any Industry.  
*Sullins Finds the Perfect Fit.*

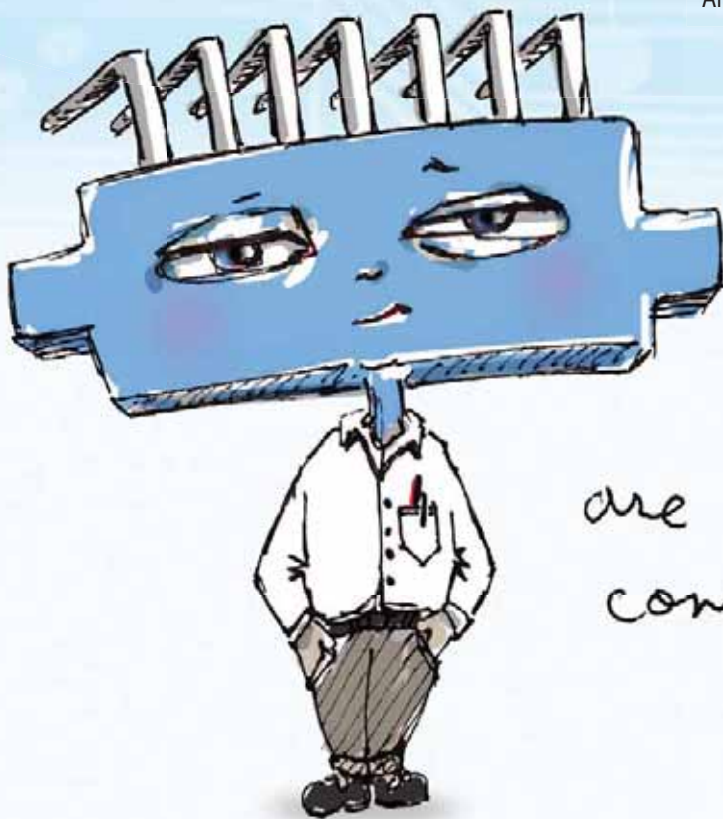

*are you a  
connectorhead?*



Order Samples & Products:  
[www.sullincorp.com](http://www.sullincorp.com)  
[info@sullincorp.com](mailto:info@sullincorp.com)  
888.774.3100 toll-free

**USA HQ** | 801 E Mission Rd, San Marcos, CA 92069, USA  
+1-760-744-0125 | fax +1-760-744-6081

**Taiwan** | 10F, NO 268, Fuxing S. Rd., Sec. 2, Taipei, Taiwan  
+886-2-2738-7377 | fax +886-2-2738-3586

