

NUVOTON CODECS And Electret Microphones

Operating voltage ranges continue to decrease with newer devices. Particularly in cell phones and VoIP telephones, the surrounding components often need to change as well. The older devices operated at a nominal 5 VDC and were often powered by four cells. The new devices released by Nuvoton have nominal operating voltages of 3.0 VDC or 3.3 VDC.

Because of the battery requirements changing, the microphone circuits must change also.

An electret microphone is the most cost effective omnidirectional microphone you can buy. Electret microphones can be very sensitive, very durable, extremely compact in size and have low power requirements. Electret microphones are used in many applications where small and inexpensive microphones with good performance characteristics are required. Most lavalier (tie clip) microphones, consumer video camera microphones and computer sound card microphones are electret microphones.

The electret is a modified version of the classic capacitor (or condenser) microphone. It exploits changes in capacitance due to mechanical vibrations to produce voltage variations proportional to the sound waves. Whereas the condenser microphone needs an applied (phantom) voltage, the electret has a built-in charge. The few volts needed are to power the internal FET buffer, not to create an electric field.

A typical electret capsule is a two terminal device (there are also 3 pin capsules.) It appears as a current source when biased between 1 and 9 volts, routinely consuming less than half a milliamp. This power is used by a very small FET preamplifier built into the microphone capsule. This preamplifier converts the very high impedance source of the electret element itself to a lower impedance for the following amplifier. (It is because of this amplifier that it is important to know the electrets are polarity sensitive and accidental reversal can result in very poor audio performance.)

The load resistor defines the impedance and can be matched to the low noise amplifier intended. This is usually a 1-10k Ω resistor. The lower limit is defined by amplifier voltage noise and the upper limit by interference pickup (and amplifier current noise). Suitable resistance values are typically in the range of 1-10 K Ω . In many cases, the microphone is powered from 1.5V-5V power source through a resistor of a few kilohms.

Although normal electret microphones have a wide overall operating range, they have a standard voltage at which all their parameters are specified. In the past, with the higher supply voltages, this was less critical. Now, the standard voltage of the electret microphones is dropping to match the new IC components. Thus, the relative levels recorded into the chips will decrease unless component changes are made.

For example, the electret microphones featured in a recent Panasonic catalog have standard and -3 dB voltages as illustrated below:

MODEL #	Std. Op. Voltage	-3 dB Voltage
WM-034B	4.5V	3.0V
WM-038A	4.5V	2.0V
WM-54B	2.5V	2.0V
WM-034L	2.5V	
WM-063	2.0V	1.5V
WM-034D	1.5V	1.0V
WM-52B	1.5V	1.1V
WM-034F	1.5V	1.0V

Table 1.

Nuvoton Applications normally suggests a 2-terminal differential microphone circuit as standard. This is because it allows the common mode rejection of the microphone amplifier to suppress any digital noise on the power and ground lines. Thus, the digital noise will not be amplified by the microphone amplifier. The only precaution is that the metal case of the microphone cannot contact ground.

An example differential microphone circuit, illustrated in Fig. 1, consists of three resistors and three capacitors. R_f and C_f provide decoupling from the main supply line in order to provide clean DC to the microphone. This is important, for the electret microphone has a very low output (typically 2 to 20 mV) that must be amplified to provide proper levels.

The two resistors, labeled R_d , are the differential load resistors that balance the microphone input to the input pins of the CODEC input amplifier. They also limit the DC current, and thus the available voltage, across the electret microphone. Capacitors C_b are DC blocking capacitors to prevent an interaction between the bias on the microphone and the bias on the microphone input pins of the CODEC.

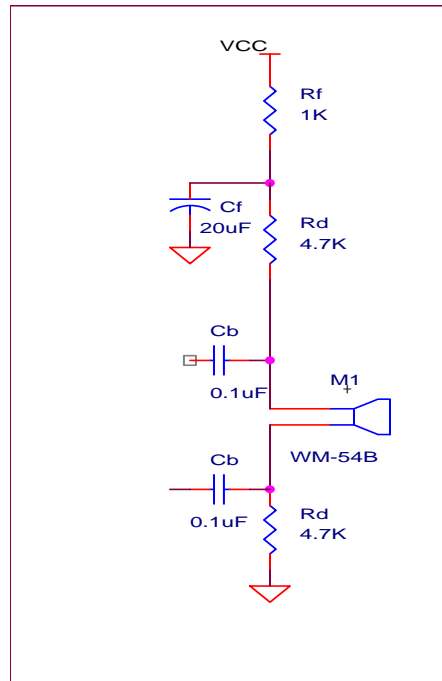

Figure 1.

With 5 VDC chips the application circuits typically used $R_f = 1K\Omega$ and $R_d = 10K\Omega$. The Panasonic WM-034B, or Radio Shack 270-090, microphones with standard voltages of 4.5V ended up with approximately 2.25V across them. They were operating with only 50% of the “standard” voltage so they were already at their -3 dB point for sensitivity.

Interestingly, directly substituting the WM-54B (Standard voltage 2.5V) into the same circuit resulted in only 948 mV across the microphone. The lower voltage microphone was actually operating at only 38% of its standard voltage. The sensitivity was worse than before.

Because of the impedance differences and the current limiting of the microphones, the results are not easily predicted. For example, the WM-54B (2.5V) situation was fixed by reducing the R_d resistors to $4.7K\Omega$. This resulted in 3.126V across the microphone, with a 5 VDC supply. This was definitely above the standard voltage and provided adequate sensitivity.

When dropping down to 4.5 or 3.0 VDC supplies the resistor values need to be changed again. Lower “standard” voltage microphones are selected in order to maintain correct audio sensitivity. Note in Table 1 that the standard voltages range from 4.5V down to 1.5V.



The following measurements were made using the WM-54B microphone with a “Standard” voltage of 2.5V.

Configuration A optimized for 5 VDC (Rf = 1K, Rd = 4.7K)

Supply Volts	MIC Volts	MIC Current
5.0	3.20	172
4.5	2.71	169
3.0	1.47	146
2.7	1.25	140

Configuration B (Rf = 1K, Rd = 2.7K)

Supply Volts	MIC Volts	MIC Current
5.0	3.85	177
4.5	3.40	168
3.0	2.07	148
2.7	1.77	143

Configuration C optimized for 3 VDC (Rf = 1K, Rd = 1.8K)

Supply Volts	MIC Volts	MIC Current
5.0	4.24	182
4.5	3.75	178
3.0	2.34	160
2.7	2.06	154

Configuration D (Rf = 470, Rd = 4.7K)

Supply Volts	MIC Volts	MIC Current
5.0	3.27	175
4.5	2.76	170
3.0	1.53	146
2.7	1.29	140



Note that Configuration A satisfies the 5 VDC supply situations with the microphone voltage above 2.5V at both 5.0 and 4.5 VDC.

Configuration B is fine for 5.0 and 4.5 VDC but is at the -3 dB voltage at 3.0 VDC. At 2.7 VDC the microphone voltage is down to one-half of its standard voltage.

Configuration C looks good from a DC standpoint at all the voltages. It is above 2.5V for all but the 2.7V supply, where it is only down 3 dB in sensitivity.

Subjective listening tests indicated that the electret microphones and the CODEC input circuit are both quite flexible. The only noticeable difference was at 2.9 volts. Here a slight loudness difference between Configuration A and Configuration C was noticed.

Configuration D was an attempt to raise the load impedance while dropping the decoupling resistor value. The result was not satisfactory from a DC standpoint, only exceeding the 2.5V when supplied by 5.0 and 4.5 VDC. At a 3 VDC supply the voltage is not sufficient to even reach the -3 dB voltage for the WM-54B. Even Configuration B is better, as the microphone is at the -3 dB voltage when the supply is 3 VDC.

Another microphone issue that is often overlooked is the sound cavity. The design of this cavity can easily provide several more dB of gain. This passive gain requires no increased electrical power. It also does not degrade the SNR of the microphone amplifier. Many microphone manufacturers will provide a rubber "boot" that will improve the gain slightly. Using this "boot" and mounting the microphone in a cavity will definitely improve the audio output level. The best example of this is the legacy telephone handset. It was originally designed for a large carbon microphone cartridge. However, when replaced by electret microphones there was now a nice "sound cavity" which reinforced the waves into the microphone element.

In conclusion, even a simple microphone circuit may not be as simple as we expect. The first consideration is to be sure that the microphone has a low enough "standard" voltage. Then be sure that your combination of resistors lets the microphone have enough current to reach the standard voltage at the lowest expected V_{cc} . The microphones are quite flexible and the increased voltage at the highest expected V_{cc} will not change any performance. For the 3 VDC W681310 with the WM-54B microphone, Configuration C seems the best choice.

Important Notice

Nuvoton products are not designed, intended, authorized or warranted for use as components in systems or equipment intended for surgical implantation, atomic energy control instruments, airplane or spaceship instruments, transportation instruments, traffic signal instruments, combustion control instruments, or for other applications intended to support or sustain life. Furthermore, Nuvoton products are not intended for applications wherein failure of Nuvoton products could result or lead to a situation wherein personal injury, death or severe property or environmental damage could occur.



Nuvoton customers using or selling these products for use in such applications do so at their own risk and agree to fully indemnify Nuvoton for any damages resulting from such improper use or sales.