

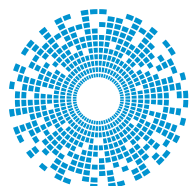

Product Highlights



bel POWER SOLUTIONS & PROTECTION

a bel group

belpowersolutions.com

About Bel

Bel is a publicly traded company that has been operated by the same family for over 65 years. Our history of organic growth and acquisitions have broadened our product portfolio. This has established Bel as a world leader with a diverse offering of power, protection and interconnect products. We design and manufacture these products which are primarily used in the networking, telecommunications, computing, military, aerospace, transportation and broadcasting industries.

Bel's portfolio of products also finds application in the automotive, medical and consumer electronics markets.

About Bel Power Solutions

Bel Power Solutions provides intelligent, efficient and reliable power conversion devices. We support global customers and local markets with strategically located manufacturing and R&D facilities. We continue to focus on the growth of our business with strategic customers and distributors. Applications of our power conversion devices range from board-mount power to system-level architectures for servers, storage, networking, industrial and telecommunications industries.

Table of Contents

Front-End Products

PFE/PET Series High Efficiency	3
FNP/FCP 300-1800W Series	3
Rack Power and Open Compute Products	4

AC-DC Products

Open Frame	5
Bulk Power	5
Modular	6
Linear Regulators	6

DC-DC Board-Mount Products

Isolated Bricks and Filters	7
Analog Point of Loads	8
Power Management & Digital Power System	9
Digital Power	10

Ruggedized Melcher Products

Wide Input Cassettes	11
Compact Cassettes	11
Rugged DC-DC Board Mount	12
Switching Regulator	12
DIN-Rail	13
CompactPCI	13

Power Conversion for eMobility

DNC Series: DC-DC Converter Product Overview	14
INV Series: DC-AC Inverter Product Overview	14
INVCHG Series: Bi-Directional Inverter Charger	14

Custom Solutions

Modified Standard and Value-Add Solutions	15
Turnkey Solutions	15

Front-End Products

With industry-leading power density and efficiency, our broad range of hot-swappable front-end products provide advanced thermal management and robust feature sets.

PFE/PET Series High Efficiency FNP/FCP 300-1800W Series

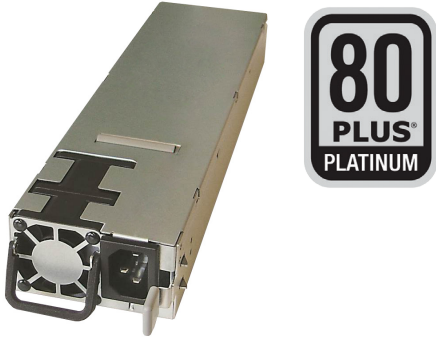

Product Highlights

- 600 to 3000 Watts
- 12Vdc Output
- AC and DC Inputs
- Platinum Efficiency (94%)
- Up to 43W/in³
- 1U Form Factor
- Forward & Reverse Airflow
- Digital Current Share
- PMBus Communication

Model	Output Power	Dimensions (mm) w/o connector (L x W x H)
AC Input		
PFE600-12-054xA	600W	321.5 x 54.5 x 40
PET750-12-050xA	750W	300 x 50.5 x 40
PET800-12-074xA	800W	185 x 73.5 x 39
PFE850-12-054xA	850W	321.5 x 54.5 x 40
PFE1100-12-054xA	1100W	321.5 x 54.5 x 40
PET1300-12-054xA	1300W	321.5 x 54.5 x 40
PFE1300-48-054NA	1300W	321.5 x 54.5 x 40
PET1600-12-074NA	1600W	265 x 73.5 x 40
PET2000-12-074NA	2000W	265 x 73.5 x 40
PFE3000-12-069RA	3000W	555 x 69 x 42
DC Input		
PFE1100-12-054xD	1100W	321.5 x 54.5 x 40

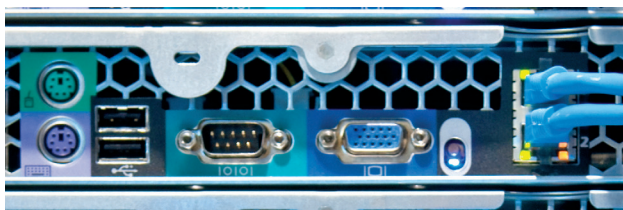

Product Highlights

- 300 to 1800 Watts
- 3 Form Factors:
 - 1U, 84mm Form Factor
 - 1U, 102mm Form Factor
 - 1U, 141mm Form Factor
- AC and DC inputs
- Forward & Reverse Airflow
- Analog Droop Current Share
- I²C Bus Communication

Variety of mounting styles for numerous applications

Model	Output Power	Dimensions (mm) w/o connector (L x W x H)
AC Input		
FNP300-1012G	300W	215.9 x 101.6 x 40.1
FCP-400-12G	400W	215.9 x 101.6 x 40.1
FNP600-12G	600W	298.2 x 85.8 x 40.6
FNP850-12G	850W	298.2 x 85.8 x 40.6
FNP850-12RG	850W	298.2 x 85.8 x 40.6
FNP1500-12G	1500W	279.4 x 141.2 x 40.5
FNP300-1024G	300W	215.9 x 101.6 x 40.1
FNP300-1048G	300W	215.9 x 101.6 x 40.1
FNP600-48G	600W	298.2 x 85.8 x 40.6
FNP1000-48G	1000W	298.2 x 85.8 x 40.6
FNP1500-48G	1500W	279.4 x 141.2 x 40.5
FNP1800-48G	1800W	279.4 x 141.2 x 40.5
DC Input		
FND300-1012G	300W	215.9 x 101.6 x 41.9
FND850-12RG	850W	315.1 x 85.8 x 40.6
FND850-12DRG	850W	315.1 x 85.8 x 40.6

Rack Power and Open Compute Products



Product Highlights

- Up to 18kW per Rack
- Racks may be Paralleled
- AC Inlet in Front on FNR
- AC Inlet in Back on FXR
- Analog Droop Current Share
- I²C Bus Communication
- I²C to USB Interface

Rack	PSU Series	Max # of Supplies	V _{OUT}	Vstdby	Power (W)
FNR-5-12G	FNP600/850	5	12V	12V @ 2.5A	4250
FNR-3-12G	FNP1500-12G	3	12V	12V @ 1.5A	4500
FXR-3-32G	FXP1500-32G	3	32V	12V @ 1.5A	4500
FNR-5-48G	FNP600/100	5	48V	12V @ 2.5A	5000
FNR-3-48G	FNP1500/1800	3	48V	12V @ 1.5A	5400
FXR-3-48G	FXP1500/1800	3	48V	12V @ 1.5A	5400
SPSPFE3-02G	PFEE3000	6	12V	12V	18,000
SPSPFE3-03G	PFEE3000	6	12V	12V	18,000
SPAFCBK-08G	SPAFCBK-07G	7	12V	NA	4,900
SPAFCBK-12G	SPAFCBK-11G	3	12V	NA	9,900

V2 Shelf (SPAFCBK-12G)

- Holds Three SPAFCBK-11G PSU's
- Form Factor: 139 x 534.5 x 650mm
- Three-phase 200/277Vac Input
- Single Bus Bar System (530A)
- Redundant Configuration (2+1)
- Power Modules and Batteries in the Same Shelf
- High Efficiency PSU Exceeds Titanium Efficiency Levels at Most Load Points

18kW Shelf (SPSPFE3-0XG)

- Holds up to Six PFE3000-12-069 PSU's
- Form Factor: 46.5 x 436 x 650mm
- Three-phase, 400/480Vac Input (-02G) or Three-phase 208Vac Input (-03G)
- 3 Sets of Output Blades
- Redundant Configurations (3+3 or 5+1)
- I²C PMBus, Optional Ethernet Capability
- High Efficiency PSU Exceeds Titanium Efficiency Levels at Most Load Points



AC-DC Products

Broad offering of standard and modified standard products to cover a wide variety of industrial and medical applications.

Open Frame

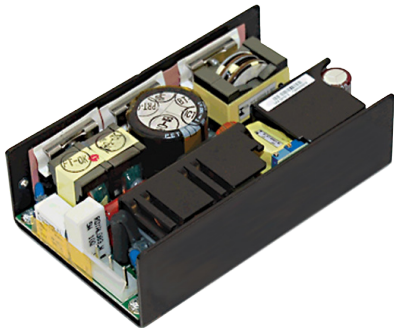

Product Highlights

- A Wide Variety of Single and Multiple Output Models
Up to 600 watts
- 90-264Vac Input
- ABC and MBC Low-Profile Series Offer High Power Density and Efficiency Up to 94%
- Commercial to EN60950
- Fan Output, 12Vdc @ 0.5A Standard
- EMI Level B
- -20°C to 70°C Operation
- Cover Kits Available on Some Models

Series	V _{IN}	V _{OUT}	Power (W)
ABC	90 - 264	5 - 48	40 - 600
MBC*	90 - 264	5 - 48	40 - 600
MAP	85 - 264	5 - 30	40 - 130
MPB	90 - 264	3.3 - 48	125 - 150
MPU	85 - 264	3.15 - 13.2	150 - 200
PFC	85 - 264	3.3 - 48	250 - 500

*Medical to EN60601-1, 3rd Edition with 2 x Means of Patient Protection (MOPP) Isolation

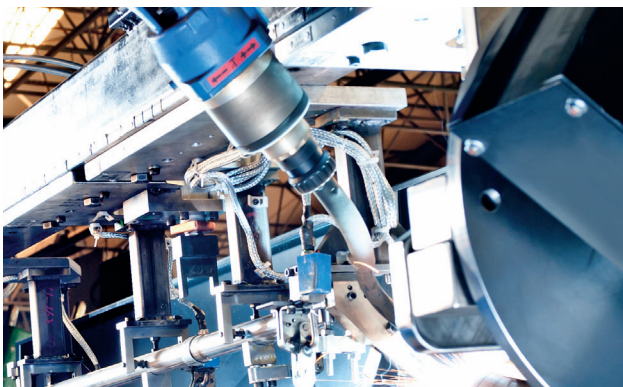

Bulk Power



Product Highlights

- Scalable Output Power (up to 21kW)
- 3 Phase and 1 Phase Inputs
- Extra-wide Output Voltage Trim (20-57 Vdc)
- Remote Output Adjustment and Monitoring
- Scalable Output Power to 21kW

Series	V _{IN}	V _{OUT}	Power (W)
BPEU2488	90 - 264 VAC (1P)	50Vdc @ 20A 28Vdc @ 6A	1300
BPEU2413	185 - 264 VAC (1P) 175 - 240 VAC (3P)	2x 50Vdc @ 12A 50Vdc @ 2A 4Vdc @ 1.5A 5Vdc @ 1A	1400
BPEU5352	185 - 264 VAC (1P)	45Vdc @ 31A 27Vdc @ 8.9A	1700
BPEU5452	185 - 264 VAC (1P) 175 - 240 VAC (3P)	40 - 51Vdc @ 40A	2000
BPEU2000	185 - 264 VAC (1P)	40 - 50Vdc* @ 40A 12Vdc @ 0.5A	2000
BPEU2452	185 - 264 VAC (1P)	48V @ 40A 12.5V @ 1A	2000
BPEU2489	185 - 264 VAC (1P)	+50V @ 32A +24V @ 1.5A	2000
BPEU2451	185 - 264 VAC (1P)	2x 30 - 50*Vdc @ 40A 24Vdc @ 3.5A	3000
BPEU3000	185 - 264 VAC (1P) 170 - 242 VAC (3P)	4x 50V @ 23.5A 48V @ 2.5A 5V @ 0.5A	3000
BPEU3003	185 - 264 VAC (1P) 175 - 242 VAC (3P)	48V @ 60A 48V @ 2.5A 24V @ 1.2A	3000
TCP3500	180 - 528, 3ph	18 - 65Vdc adj	3500
TXP3500	180 - 528, 3ph	0 - 65Vdc adj	3500
FXC7000	220 - 480, 3ph	48Vdc	6000 or 7000
FXP7000	220 or 480, 3ph	32 or 48	6000 or 7000

Modular



Product Highlights

- LPM/LMM 409 up to 900W and 8 Outputs
- LPM/LMM 616 up to 1600W and 12 Outputs
- AC Input up to 440Hz via Terminal Block
- LMM 2X MOPP and 3rd Edition Medical approvals
- Radiated and Conducted Emissions - Class B
- Full Load Operation from -20°C to 50°C

LPM/LMM: Output Modules

Designation	Outputs	Voltage	Output 1 Max Power	Current (max)
E	1	2.5V to 5.3V	265W	53A (61.2A)
F	1	5.2V to 15V	265W	22A (25.5A)
G	1	14V to 30V	265W	11A (12.7A)
H	1	29V to 44V	265W	7.4A (8.5A)
J	1	43V to 54V	265W	5.5A (6.4A)
K	1	1.5V to 15V	90W	6A (7A)
L	1	1.5V to 32V	90W	3A (3.6A)
M	2	1.5V to 15V	90W	6A (7A)
N	2	1.5V to 32V	90W	3A (3.6A)



Visit our online configuration tool: lpm.belpowersolutions.com

Linear Regulators

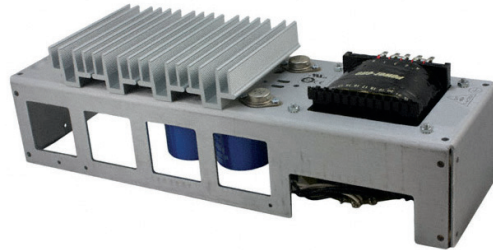

Product Highlights

- Low Output Noise
- Very Broad Offering
- Single, Dual and Triple Output Models
- Approved to IEC 60950-1
- MTBF Over 300 k Hrs.
- Low Output Ripple
- Industry Standard Sizes
- OVP Options Available

Series	V _{IN}	V _{OUT}	Power (W)
Single Output			
F	100 - 264	5 - 28	192 - 288
G	100 - 264	5	175
Hx	100 - 264	5 - 28	7.5 - 192
Dual Output			
Hxx	100 - 264	5 - 24	9.6 - 150
Triple Output			
Hxxx	100 - 264	5 - 15	16 - 150
CP131	100 - 264	5 - 15	51 - 85

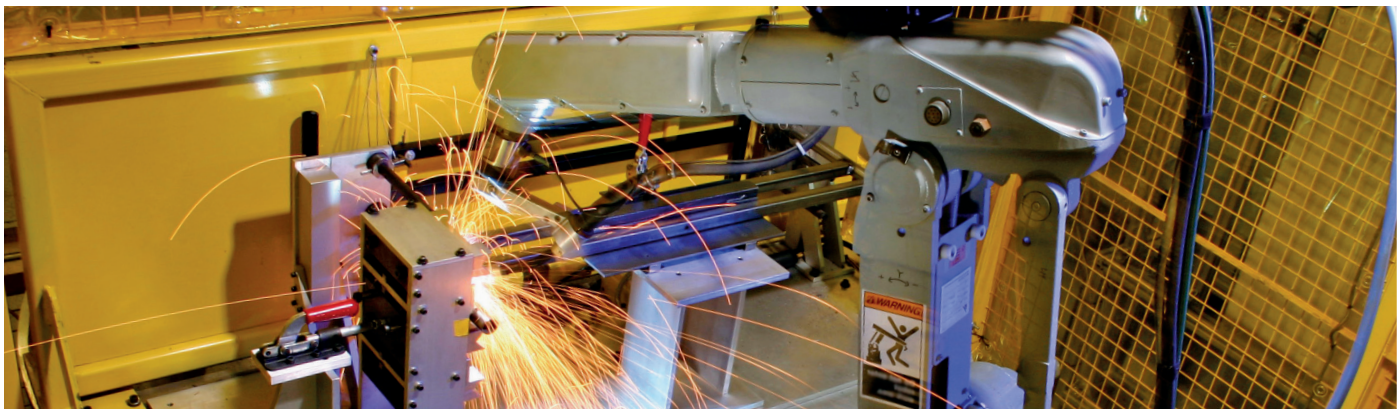

DC-DC Board-Mount Products

Offering a comprehensive range of high power density, board-level DC-DC converters. Including industry standard sixteenth to half brick isolated brick converters, analog POLs and feature-rich digital power solutions that seamlessly integrate power conversion and management.

Isolated Bricks and Filters

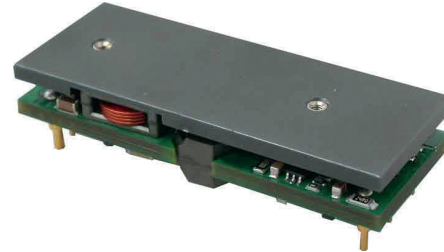

Product Highlights

- Sixteenth Brick to Half Brick Form Factors
- Wide (4:1) and Narrow (2:1) Input Ranges
- Through Hole (THT) and Surface Mount (SMT) Options
- Output Voltages from 0.5Vdc to 15Vdc
- High Power Density

Single Output

Model	Mount	V _{in}	V _{out}	Max Power
1/16 Brick (0.9"x1.3")				
ORSB/ SRSB	SMT, THT	36-75	1.2, 1.5, 1.8, 2.5, 3.3, 5.0, 12.0	100W
UIS	THT	18-75	3.3, 5.0, 12.0	72W
1/8 Brick (0.896"x2.3")				
ORCY	THT	18-36	1.8, 3.3, 12.0	120W
ORCY	THT	36-75	1.2, 1.5, 1.8, 2.5, 3.3, 5.0, 12.0	300W
UIE	THT	18-75	3.3, 5.0, 12.0	120W
1/4 Brick (1.45"x2.3")				
ORQB	THT	18-36	5.0, 12.0	240W
ORQB	THT	36-75	1.2, 2.5, 3.3, 5.0, 12.0	600W
UIQ	THT	18-75	3.3, 5.0, 12.0	240W
1/2 Brick				
ORHB	THT	9-36	15.0	100W
ORHB	THT	36-75	1.2, 1.5, 1.8, 2.5, 3.3, 5.0, 12.0	600W

Dual Output Isolated Bricks

Two independently regulated outputs.

Model	Mount	V _{in}	V _{OUT1}	V _{OUT2}	I _{OUT1}	I _{OUT2}
1/4 Brick (1.45"x2.3")						
QD/ ORQB	SMT, TH	36-75	1.0 1.2 1.6 1.8 2.0 2.5 3.3 12	1.5 1.8 2.5 3.3 3.4 5.0 -12	2.7A 10A 12A 13A 15A 18A 25A	1.5A 5A 7A 8A 10A 12A 15A

Regulated Bus Converters (RBC)

- Industry Standard Pin-Outs
- Excellent Thermal Performance
- Direct Current Sharing

RBC Modules

Model	V _{in}	V _{OUT}	Max I _{OUT}	Max Power
1/16 Brick (0.9"x1.3")				
ARSB-D5S10L	45 - 56V	10.6V	24A	250W
1/8 Brick (0.896"x2.3")				
ORRE-32S10R	38 - 55V	8.2V	36A	300W
ORCY-Q0S10L	45 - 56V	9.7V	41	400W
ARCY-F0S10L	45 - 56V	10.4V	48A	500W
1/4 Brick (1.45"x2.3")				
ORRQ-45M11R	51 - 55V	9.7V	51A	480W
ORQB-S0S12L	45 - 56V	10.4V	60A	600W
ORQB-E0S10L	51 - 56V	9.6V	85A	810W
ORQB-S0M11L	48.6 - 60V	11.2V	62.5A	700W
ORQB-F5S11L	38 - 56V	10.6V	52A	550W
ARQB-X0S10L	45 - 56V	10V	100A	1000W

Input Filters

The F and FC Series of input filters minimize the conducted and radiated emissions generated by switch mode DC-DC converters and allow them to meet string cut FCC and EN5022 Class B conducted emissions requirements.

Model	Rated Voltage	Current (max)	Board THT	Dimensions
F2410-G	0 - 45V	10A	Mount SMT	1.00x .750 x 0.26
F4804A-G	0 - 45V	4A	Mount SMT	1.20 x .815 x 0.38
F4810-G	0 - 80V	10A	Mount SMT	1.20 x .815 x 0.38
FC100V5A-G	0 - 100V	5A	Board THT	1.00 x 1.00 x 0.40
FC100V6A-G	0 - 100V	6A	Board THT	1.00 x 1.00 x 0.40
FC100V10A-G	0 - 100V	10A	Board THT	2.00 x 1.00 x 0.44
FC100V20A	0 - 100V	20A	Board THT	2.05 x 1.65 x 0.46

DC-DC Board-Mount Products

Analog Point of Loads

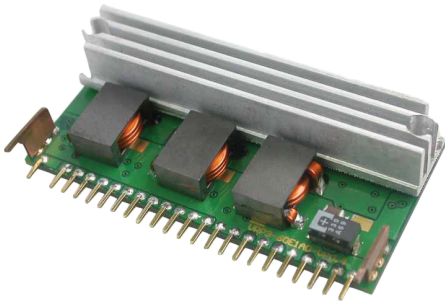

Analog Point of Loads

- Exceptional Thermal Performance in High Temperatures
- Ultra High Efficiency, Slim Profiles and Highly-Regulated Programmable Output Voltages
- Tightly Regulated Programmable Output Voltages
- Exceptional Thermal Performance in Environments Up to 85°C, Programmable Output Voltages
- Industry-Standard Through-Hole SIP, Exceptional Thermal Performance, Programmable Output Voltages

Series	Input Voltage Range	Output Voltage Range	Output Current Range
YEV	4.25V - 13.8V	0.59V - 5.1V	3A - 20A
YH	5V - 13.8V	0.6V - 3.63V	up to 40A
YM	3V - 14V	0.7525V - 5.5V	up to 5A
YS	3.0V - 5.5V or 9.6V - 14V	0.7525V - 5.5V	10A - 16A
YNV	3.0V - 5.5V or 9.6V - 14V	0.7525V - 5.5V	5A, 10A, 16A
YV	5.0V - 13.8V or 10V - 14V	0.6V - 1.98V	up to 60A
VRAx	4.5V - 13.8V	0.59V - 5.1V	up to 10A
ORPx	4.5V - 13.8V	0.591V - 5V	up to 50A
VRPx	4.5V - 13.8V	0.591V - 5.1V	up to 90A

SRPE Product Highlights

- Vertical Surface Mount Configuration
- Compensation-Less COT Control

Part Number	Input Voltage	Output Voltage	Max Output Current
SRPE-02E1A0	5.5 - 13.2V	0.6 - 5.5V	1.5A
SRPE-03E1A0	5.5 - 13.2V	0.6 - 5.5V	3A
SRPE-06E1A0	5.5 - 13.2V	0.6 - 5.5V	6A
SRPE-12E1A0	5.5 - 13.2V	0.6 - 5.5V	12A
SRPE-20E1A0	4.5 - 13.2V	0.6 - 2.0V	20A
SRPE-30E1A0	4.5 - 13.2V	0.6 - 2.0V	30A
SRPE-50E1A0	7.5 - 13.2V	0.6 - 2.0V	50A



Voltage Regulator Module (VRM)

- Meet the Stringent Dynamic Response and High Current Requirements Posed by Today's Microprocessor Applications
- Compatible to Intel VRM Specification, VRM8.5 through VRM12.x
- Input 12V or Wide Ranges
- Output Currents from 30A to 165A

VRM Spec	Input Voltage	Output Voltage	Max Output Current
VRM8.5	10.3 - 13.2V	1.05 - 1.825V	30A
VRM9.x	3 - 15V	1.05 - 1.85	81A
VRM10.x	10.3 - 13.2V	0.8 - 2.5V	150A
VRM11.x	4.5 - 13.2V	0.5 - 1.6V	120A
VRM12.x	6.5 - 13.8V	0.6 - 1.52V Dual	Dual 165A/25A
AMD	10.8 - 13.2V	0.83 - 1.4V	30A

Tunable Loop™ Product Highlights

- Max Input Voltage 3V – 14.4V
- Max Output Current 2A – 50A
- Max Output Power 10W – 100W
- Remote On/Off
- Adjustable Output Voltage
- Over Current and Over Temperature Protection
- Output Voltage Sequencing Option
- PMBus Enabled Versions



Series	Input Voltage Range	Output Voltage Range	Output Current Range
SLIN	2.4 - 14V	0.59 - 5.5V	2A - 50A
SLAN	3 - 14.4V	0.6 - 5.5V	3A - 40A
SLDN	3 - 14.4V	0.45 - 5.5V	3A - 40A
SLIM	3 - 14.4V	0.45 - 5.5V	6A - 12A*
SLDM	3 - 14.4V	0.45 - 5.5V	6A - 12A*

*Ultra thin modules with a maximum height of 0.11"

DC-DC Board-Mount Products

Digital Power System

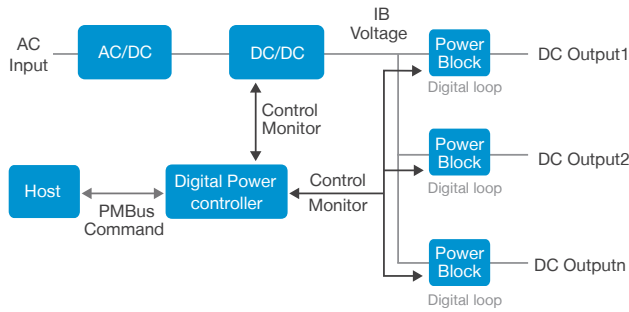

Digital Power System



TRKB-80D62ER

Digital Power System Controller

- DSP Engine with Bel's Firmware
- Digital PID Loop
- Controls Up to 6 Power Blocks and 2VRM
- Sequencing and Timing Logic
- Fault Detection and Action
- Monitoring and Reporting
- PMBus Compatible

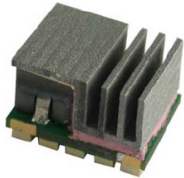

Power Blocks

- Max Input Voltage up to 14V
- Max Output Current up to 130A
- High Power in a Small Footprint
- High Efficiency

Part Number	Input Voltage	Nominal Output Voltage	Max Output Current
VRPL-06G1A0	8 - 14V	0.8 - 3.3V	6A
SRPL-06G1A0	8 - 14V	0.8 - 3.3V	6A
SRBB-20A1A0	7 - 13.2V	0.8 - 5.0V	20A
VRPL-20G1A0	8 - 14V	0.8 - 3.3V	20A
SRPL-20G1A0	8 - 14V	0.8 - 3.3V	20A
SRBL-30A1A0	7 - 13.2V	0.8 - 5.0V	30A
VRPL-30G1A0	8 - 14V	0.8 - 3.3V	30A
SRPL-30G1A0	8 - 14V	0.8 - 3.3V	30A
SRBL-60A1AC	8 - 13.2V	0.6V - 3.3V	60A
SRBL-C3A1AC	8 - 13.2V	0.6V - 3.3V	130A

Power Management



On-Board Power Management IC

- DSP Engine with Bel's Firmware
- Sequencing Up and Down Logic Control
- Fault Detection and Reporting
- Voltage Margining via Closed Loop Trim
- Analog Input Monitoring
- Configurable Through Serial Interface/PMBus
- Power-down Data Log for Identifying Fault Conditions
- SMD; 44/64/100 Pin TQFP

Part Number	Input Voltage	Control & Monitor POL Number	Monitor VRM Number	Monitor Analog Input Number
TRKF-44D62ER	3.3V	4	0	2
TRKF-64D82ER	3.3V	8	2	2
TRKF-10DC4ER	3.3V	12	4	3

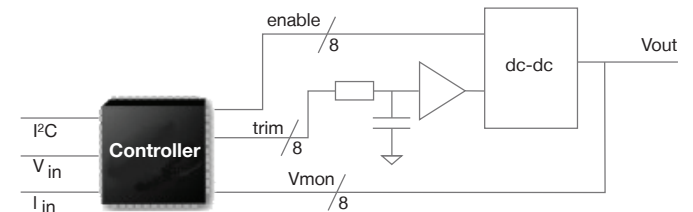

Digital Power

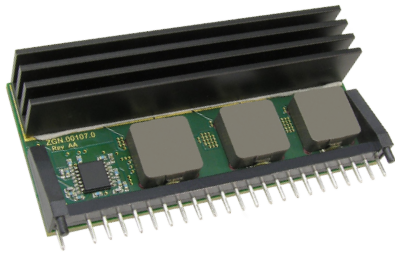

Digital Point of Loads

- Output Voltage Range of 0.7V to 5.5V
- Margining
- Enhanced Thermal Performance
- Switching Frequency 500 kHz - 1.0 MHz
- Duty Cycle Limit to 98%
- Turn-on and Turn-off Slew Rates: 0.1V...8.3 V/msec
- Turn-on Delay: 0...255 msec
- Turn-off Delay: 0...63 msec
- Load Regulation (Optimal Voltage Positioning)
- Auto Configuration of Feedback Loop
- Compensation (PID)
- Interleave (Phase Shift)
- OCP, UVP, OVP, and PG Thresholds and Types

Part Number	Mounting Type	Position	Output Current	Power (W)
DP7007G	SMT	Horizontal	7A	38.5
DP7010G	SMT	Horizontal	10A	55
DP7015G	SMT	Horizontal	15A	82.5
DP7115G	SMT	Vertical	15A	82.5
DP7120G	SMT	Vertical	20A	110
DP7130G	SMT	Vertical	30A	165
DP8105G	THT	Vertical	5A	27.5
DP8110G	THT	Vertical	10A	55
DP8120G	THT	Vertical	20A	110
DP8140G	THT	Vertical	40A	220
DP8160G	THT	Vertical	60A	330

Benefits of d-pwer™

- No External Components are Required
- Fully Programmable Using GUI, I²C Bus or Pin-Strapping
- Configuration Settings are Stored in DPM's NV Memory
- dPOLs Do Not Have NV for Increased Reliability
- dPOLs are Fully Operational with Hardwired Default Settings
- V, I, T are Constantly Reported for Each dPOL
- Can be Accessed via I²C Bus

Digital Power Manager

- Programming, Synchronization, Control, and Monitoring of up to 32 Independent dPOLs
 - DM73XX - 9mm x 9mm 64-pin QFP Package
- Communication with Host System via I²C Interface
 - Data Conversion Between I²C and POLs
 - Communicates with POLs via the SD Line, which is Isolated from the System I²C
- Storage and Protection of Information
 - Stores Configuration Data in Non-Volatile Memory
 - Protects Data Integrity with CRC, Readback, etc.
- Supervisory Functions
 - IBV UV and OV Protection with Programmable Thresholds
 - Communication with the AC/DC Front End, DC/DC Bus Converter, Optional Crowbar, and Other System Devices via Hardware Interfaces
 - 1KB of User Memory, Runtime Counter, etc.

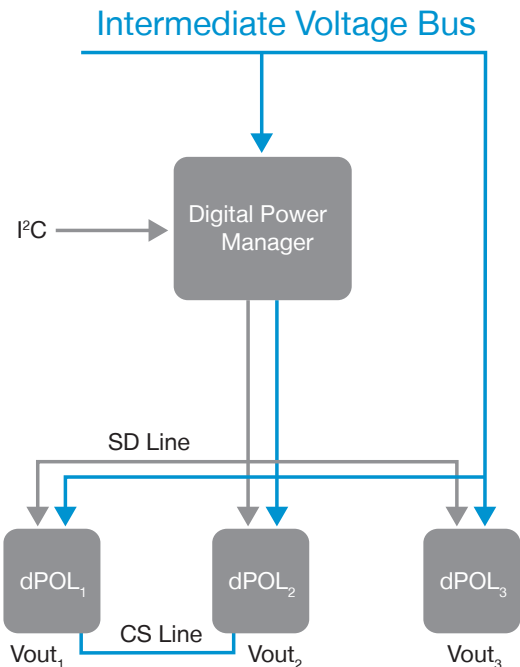

Ruggedized Melcher Products

Rugged, reliable power solutions designed to perform when failure is not an option.



MELCHER
The Power Partners.
a bel power solutions brand

Wide Input Cassettes



Product Highlights

- Ultra Wide Inputs for 12 – 220V Batteries
- Conformally Coated
- Tested and Approved for Railway
- Immune to Extreme Harsh Environmental Conditions
- Convection Cooled for Ta -40°C to +71°C No Derating (to 85°C with Derating)
- Full I/O Protection and Filters

Accessories:

Mating Female Connectors, Including Retention Devices
Baseplates (Chassis/Wall Mount), Heatsinks
DIN-Rail Mounting Kits
Front Panels, Rack Systems
Temperature Sensors for Battery Charging

Series	V _{IN}	V _{OUT}	Power (W)
AM, AS, AK	8 - 35Vdc	1 - 48V	50, 100, 150
BM, BS, BK	14 - 70Vdc	1 - 48V	50, 100, 150
CM, CS, CK*	28 - 140Vdc	1 - 48V	50, 100, 150
DM, DS, DK	44 - 220Vdc	1 - 48V	50, 100, 150
EM, ES, EK	67 - 385Vdc	1 - 48V	50, 100, 150
FM, FS, FK	20 - 100Vdc	1 - 48V	50, 100, 150
LM, LS, LK	85 - 264Vac (47- 440Hz) 88 - 372Vdc	1 - 48V	50, 100, 150
HRL, HR, HRP	12 - 168Vdc	5 - 110V	144 - 288

* Outputs configurable in parallel or series.

Compact Cassettes



Product Highlights

- Reduced Ambient Temperature
- Tested and Approved for Railway
- Immune to Extreme Harsh Environmental Conditions
- Convection Cooled for Ta -40°C to +71°C
- No Derating, Higher Power at 50°C
- Full I/O Protection and Filters

Accessories:

Mating Female Connectors, Including Retention Devices
Baseplates (Chassis/Wall Mount), Heatsinks
DIN-Rail Mounting Kits
Front Panels, Rack Systems
Temperature Sensors for Battery Charging

Series	V _{IN}	V _{OUT}	Power (W)
BQ, BP	14.4 - 36Vdc	3.3 - 96V	80 - 190
CQ, CP	33.6 - 75Vdc	3.3 - 96V	80 - 190
DQ, DP	43 - 108Vdc	3.3 - 96V	80 - 190
EQ, EP	65 - 150Vdc	3.3 - 96V	80 - 190
GQ, GP	21.6 - 54Vdc	3.3 - 96V	80 - 190
HP*	12 - 168Vdc	3.3 - 110V	100 - 150

* Outputs configurable in parallel or series.



Rugged DC-DC Board-Mount



Product Highlights

- Wide Input Voltage Ranges
- Efficiency up to 93.5%
- Wide Operating Temperature Ranges with ability to startup at -40°C or below and no Derating to 70°C
- Isolated Converters with Magnetic Feedback
- I/O Test Voltages up to 3kVac
- Low Output Ripple and Excellent Dynamic Response
- Meet or Exceed National and International Railway Standards with Little or No External Components, in Compliance with EN50155 and EN50121
- Variety of Mounting Styles for Numerous Applications

Series	V _{IN}	V _{OUT}	IOUT (A)
IMX4	4.7 - 121	3.3 - 48	1.2A
IMX7	8.4 - 150	3.3 - 48	2.1A
IMX15/IMY15	8.4 - 150	3.3 - 48	4.5A
IMX35	9 - 150	5 - 60	7A
IMX70/IMY70	12 - 154	5 - 48	16A
IBX15	15.4 - 154	50 - 160	N/A
ORQB	9 - 36	12	13A
ORQB	14 - 154	5	3A
ASQ24*	18 - 36	1.5 - 15	15A
ASQ28*	18 - 36	1.5 - 5	15A
ASQ48*	36 - 75	1.5 - 5	15A

* Startup at -55°C Operating temperature up to 100°C baseplate

Switching Regulator



Product Highlights

- Inputs up to 40V, 80V, or 144V
- Buck Converter – No I/O Isolation
- Outputs 3.3V up to 48V (Vo >Vin min)
- Output Ratings from 50W to 720W
- Output Trim 0% to 108%
- Efficiency up to 96%
- -40°C to +71°C, No Derating or Air Flow
- Full Metal Jacket, Rack/Chassis Mount
- Proven Design

Series	V _{IN}	V _{OUT} *	IOUT (A)
PSR, PSA*	Vo + - 40Vdc		1 - 5
PSB*	Vo + - 80Vdc	1 - 48V	3 - 8
PSC*	Vo + - 144Vdc	(All outputs are adjustable from 0 to 108% via ext. resistor)	6 - 12
PSL**	(= 2 - 10V depending on part and vin range)		6 - 12
PSS**			6 - 12
PSK**			12 - 25

* PCB or Chassis mounting
**Rack or Chassis mounting



DIN-Rail



Product Highlights

- Excellent Immunity to Environmental Conditions
- Wide Temperature Range
- Universal Vac Input Range and Additional Vdc Input
- Single and Dual Outputs
- Compact Design (O Series)
- Rectifier and Battery Charger Versions
- Class 1 Equipment
- Immunity to IEC/EN 61000-4-2,3,4,5,6,8,11

DIN-Rail Mounting Kits Available

Series	V _{IN}	V _{OUT} *	Power (W)
LOK	85 - 264Vac	5 - 60	26-50
	90 - 250Vdc		
LME1601-6PG	85 - 264Vac	24 - 30	26-50
	120 - 250Vdc		
LWR	85 - 264Vac	12 - 48	125
LWN (W Series)	90 - 350Vdc	12 - 48	250
EWR (W Series)	66 - 150Vdc	27	120
EWN (W Series)	66 - 150Vdc	27	240
LXR	85 - 264Vac	24 - 48	375
LXN	90 - 350Vdc	24 - 48	500

* Single and Multiple Outputs Available

CompactPCI®



Product Highlights

- Wide Range DC or AC Input with PFC
- Up To 550W Output Power in 3U and 6U Configurations
- 4 High Current Outputs (5V/3.3V/±12V) with Flexible Load Distribution
- Very High Efficiency and Power Density
- Integrated Oring FETs/Diodes for True Redundancy
- Inhibit and Enable Inputs
- Remote Sense Lines
- Single-Wire Current Share Function for 3 Outputs
- Hot-Swap Capability
- Overtemperature, Overvoltage, Overcurrent, and Overpower Protection

Series	V _{IN}	V _{OUT}	Power (W)
CPA AC-DC Converters - 4 Outputs			
CPA250-4530	90 - 264	5 - 12	250
CPA500-4530	90 - 264	5 - 12	500
CPD DC-DC Converters - 4 Outputs			
CPD250-4530	36 - 75	5 - 12	250
CPD500-4530	36 - 75	5 - 12	500

Compact PCI® meets the requirements of the PICMG® power interface specification for Compact PCI® systems

PCI: Peripheral Component Interconnect

PICMG:PCI Industrial Computer Manufacturers Group



Power Conversion for eMobility

The Bel Power Solutions EV Series provides on-board power conversion in hybrid and electric vehicles.

DNC Series: DC-DC Converter Product Overview



The 350DNC40-12G is a 4kW DC-DC converter that creates DC voltages in hybrid and electric vehicles suitable to power low voltage accessories.

Product Highlights

- 93% Efficiency
- Input Voltages Range 240-430/400-900Vdc
- Up to 4kW Power
- Full Galvanic Isolation Between Input and Output
- CAN Bus Serial Interface
- Liquid or Convection Cooling
- Adaptable to Various HVIL Input Connectors
- Flexible Output Connectivity
- Wide Ambient Operational Temperature Range



INV Series: DC-AC Inverter Product Overview



The 350/700INV is a high-efficiency DC/AC inverter that converts high-voltage DC power into split phase AC power required to drive AC accessory loads directly from the high voltage DC drives or battery bus.

Product Highlights

- 91% Efficiency
- Input Voltages Range 240-430Vdc
- Up to 6kW Power
- Full Galvanic Isolation between Input and Output
- CAN Bus Serial Interface
- Liquid or Convection Cooling
- Adaptable to Various HVIL Input Connectors
- Flexible Output Connectivity
- Wide Ambient Operational Temperature Range



INVCHG Series: Bi-Directional Inverter Charger



The 350/700INVCHG is a 15kW inverter charger that converts AC to DC voltages in charge mode and converts DC voltages to pure sine wave AC to power accessories.

Product Highlights

- 90% Typical Efficiency
- Input Voltages Range 240-430 / 400-900Vdc
- Charge Mode Output 250-435Vdc
- Export Power Mode Output 120/240Vac (50/60HZ)
- Liquid Cooled
- CAN Bus Serial Interface
- Wide Ambient Operational Temperature Range



Custom Solutions

Bel Power Solutions designs and manufactures a wide range of standard products, but we understand that your application may require a custom design. When your next design requires a modified standard, value-add, or even a full turnkey solution, we can help.



Modified Standard and Value-Add Solutions

- Changes in Packaging
- Modified Performance
- Value-Add

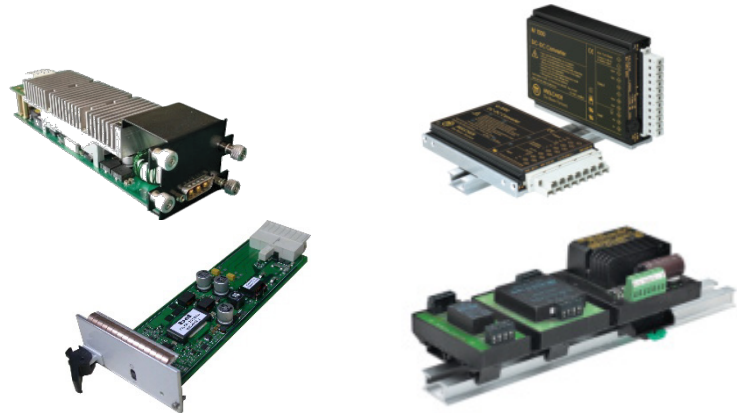

Turnkey Solutions

- Manufacturing Services
- Vertical Integration
- Design and Development

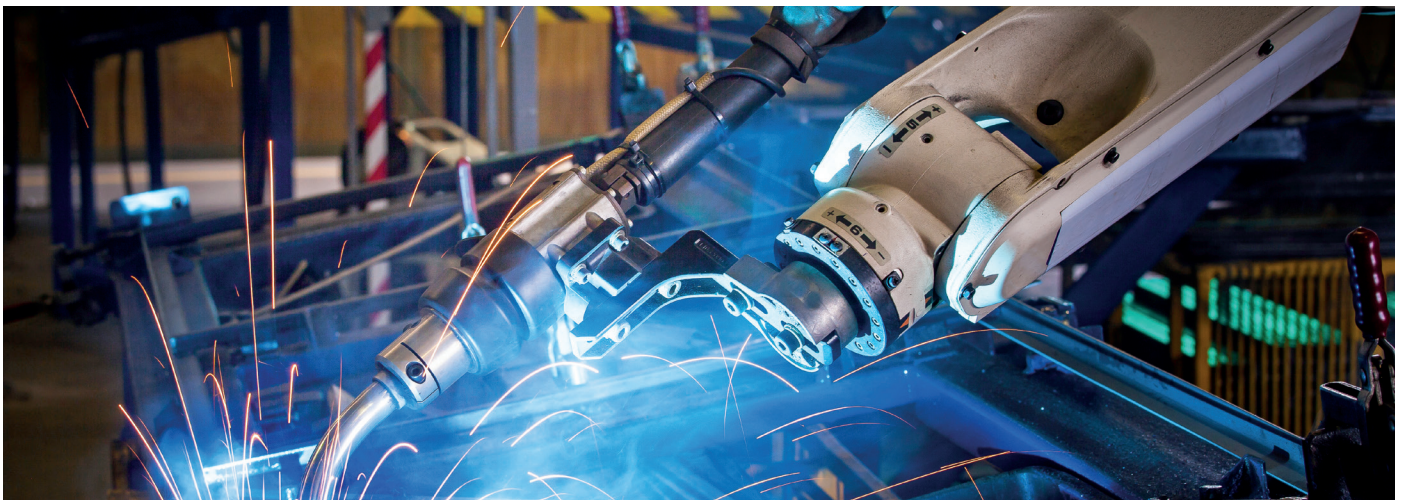



Bel Power Solutions

2390 Walsh Avenue
Santa Clara, CA 95051 USA
tech.support@psbel.com

North America

+1 866.513.2839

Asia-Pacific

+86 755 2988 5888

Europe, Middle East

+353 61 225 977

About Bel Power Solutions

Bel Power Solutions & Protection offers world-class AC-DC and DC-DC power conversion products, value-add power solutions, complete box-build solutions and contract manufacturing services, along with a complete portfolio of Electronic Circuit Protection devices. Bel Power Solutions & Protection is a market leader in railway with Melcher brand products and technology leaders in the development of high-efficiency and high power-density front-end products.

For more information about us, visit belpowersolutions.com



bel POWER
SOLUTIONS &
PROTECTION

a bel group