

# SHARP®

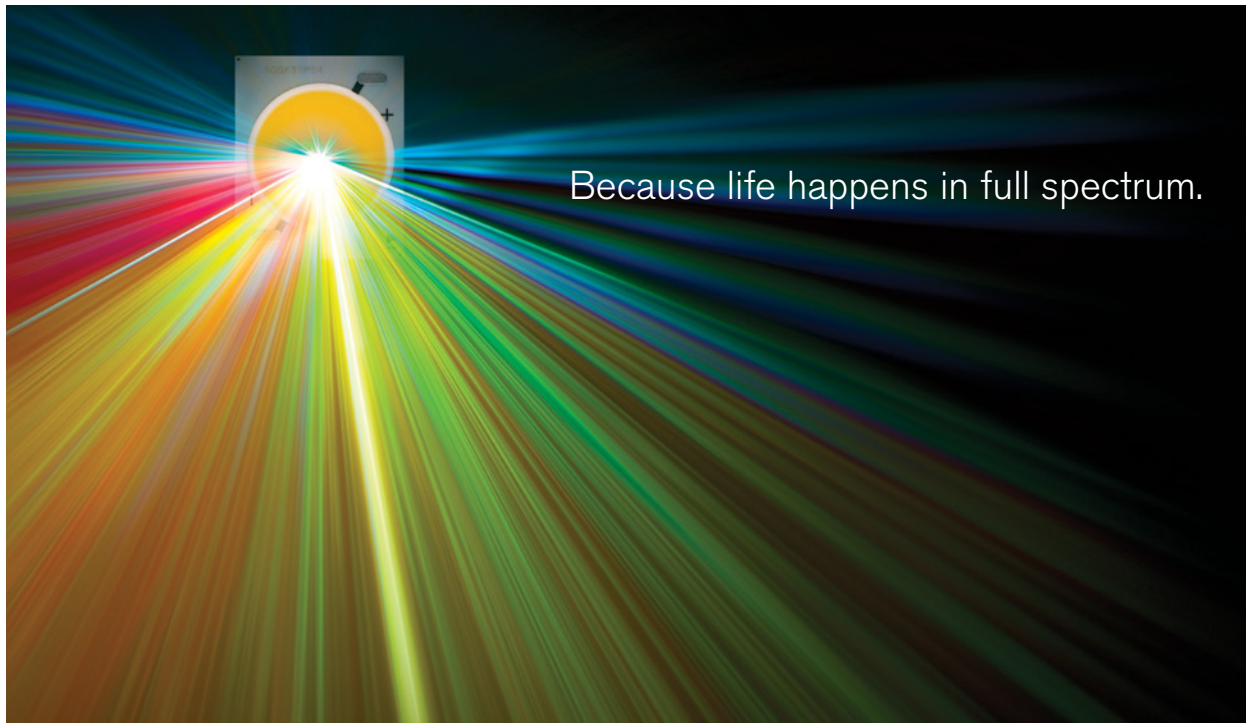

Because life happens in full spectrum.

**SHARP ZENIGATA CHIP ON BOARD**

**2013 LED LINE-UP**



# Sharp Performance for Any Environment

Lighting often makes the moment, whether it's pumping up the drama or creating an effect so subtle you don't even realize it's stealing the show. Other times, it's all about muscle. Only dependable high brightness lighting need apply...so long as it keeps power consumption to a minimum.

Whatever your need, Sharp's Zenigata COB (Chip on Board) LED family has you covered. Our ever-growing stable of products shines via proprietary Sharp "know-how" to deliver dazzling quality and high performance for your commercial, industrial, and home lighting applications.

- Uniform Light Emitting Surface (LES) = Low color shift when viewed at an angle.
- High Efficacy\* and CRI\* = Efficiency combined with dazzling light quality.
- Matched LED Forward Voltages/Lumen Outputs = Even light without hot spots.
- Low Lifetime Lumen Loss/Color Shift = 50k operating hours at top performance.
- Consistent Package Size/LES Diameters = Easier product development.

*\*See product specifications for detail on typical performance ratings.*

## One of These IS Like the Other One.

All new Sharp Mega and Mini Zenigata COB LEDs (GW6 Series) now feature:

Single-bin sorting for color consistency, module-to-module and batch-to-batch.

The new series also delivers:

- Testing/Specifying at 90°C = Proven performance at your fixture's operating temperature.
- Enhanced Performance = Updated specs on many Mega and Mini products.
- Four new Mega and Mini Zenigata power classes

Also New in 2013:

Sharp Giga Zenigata and Tiger Zenigata products.

	Power	PN	CRI
Giga Zenigata	100W*/**	GW7GAL50SGC	70
Mega Zenigata	50W	GW6DMExxNFC	80
	50W	GW6DMExxNFC	90
	35W*	GW6DMDxxNFC	80
	35W*	GW6DGDxxNFC	90
	25W	GW6DMCxxNFC	80
	25W	GW6DGCxxNFC	90
	25W	GW6DACxxNFC	70
	15W	GW6DMAxxNFC	80
	15W	GW6DGAxxNFC	90
	15W	GW6DGAxxNFC	70
Tiger Zenigata	25W*/**	GW6TGCBG4FD	90
Mini Zenigata	14W*	GW6BMSxxHED	80
	14W*	GW6BGSxxHED	90
	12W	GW6BMRxxHED	80
	12W	GW6BGRxxHED	90
	12W	GW6BMJxxHED	80
	9W*	GW6BMWxxHED	80
	9W*	GW6BGWxxHED	90
	7W	GW6BMExxHED	80
	6W*	GW6BMGxxHED	80
	6W*	GW6BGGxxHED	90

# The Mega Zenigata COB

## Power-Saving Lighting that Packs a Punch.

Have an application that requires an incandescent, halogen, or compact fluorescent bulb solution? Think again.

The Mega Zenigata COB provides a powerful, energy-saving LED alternative. Use just one LED in a fixture and gain up to 400W of incandescent equivalent light, luminous flux greater than 6000 lm, and high efficacy (high performance modules exceed 100 lm/W).

This year, Sharp introduces a 35W Power Class, as well as 70 CRI LEDs designed specifically for industrial-type lighting.

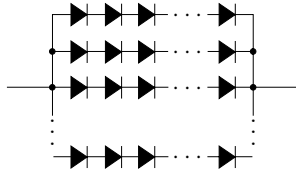
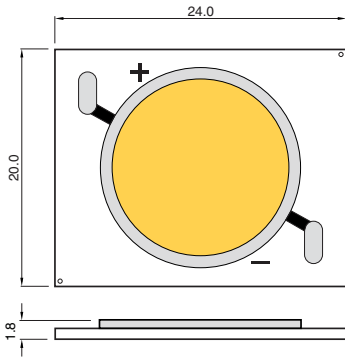

50W: (16 series  $\times$  10 parallel) = 160 LEDs

35W: (12 series  $\times$  10 parallel) = 120 LEDs

25W: (12 series  $\times$  7 parallel) = 84 LEDs

15W: (12 series  $\times$  4 parallel) = 48 LEDs

### Applications Include:

- High-Intensity Lighting
- Recessed Can Lights
- Architectural Illumination
- Down Lighting
- Spotlights
- Area and Object Lighting
- Replacement Lamp (PAR)

NOTE: Dimensions: mm

Refer to Specifications for full dimensional information

## MEGA ZENIGATA

Type	CRI Ra		Part No.	CCT (K)	Current (mA)	Voltage (V)	Luminous Flux (lm)	Efficacy (lm/W)
	Min.	Typ.						
50W - 80W Normal CRI Rjc = 0.8 K/W	80	82	GW6DME60NFC	6000	1500	53.25	6931	86.8
					950	50	4780	100.6
			GW6DME50NFC	5000	1500	53.25	6931	86.8
					950	50	4780	100.6
			GW6DME40NFC	4000	1500	53.25	6743	84.4
					950	50	4650	97.9
		83	GW6DME35NFC	3500	1500	53.25	6525	81.7
					950	50	4500	94.7
			GW6DME30NFC	3000	1500	53.25	6308	79.0
					950	50	4350	91.6
			GW6DME27NFC	2700	1500	53.25	5989	75.0
					950	50	4130	86.9
50W - 80W High CRI Rjc = 0.8 K/W	90	90	GW6DGE50NFC	5000	1500	53.25	5539	69.3
					950	50	3820	80.4
		92	GW6DGE40NFC	4000	1500	53.25	5467	68.4
					950	50	3770	79.4
		93	GW6DGE30NFC	3000	1500	53.25	5206	65.2
					950	50	3590	75.6
			GW6DGE27NFC	2700	1500	53.25	4945	61.9
					950	50	3410	71.8

 = Maximum Drive Current  = Typical Drive Current

Type	CRI Ra		Part No.	CCT (K)	Current (mA)	Voltage (V)	Luminous Flux (lm)	Efficacy (lm/W)
	Min.	Typ.						
35W - 50W Normal CRI R <sub>jc</sub> = 1.1 K/W	80	82	GW6DMD60NFC	6000	1300	38.5	4680	93.5
					950	37	3600	102.4
			GW6DMD50NFC	5000	1300	38.5	4680	93.5
					950	37	3600	102.4
			GW6DMD40NFC	4000	1300	38.5	4615	92.2
					950	37	3550	101.0
		83	GW6DMD35NFC	3500	1300	38.5	4420	88.3
					950	37	3400	96.7
			GW6DMD30NFC	3000	1300	38.5	4290	85.7
					950	37	3300	93.9
			GW6DMD27NFC	2700	1300	38.5	4082	81.6
					950	37	3140	89.3
35W - 50W High CRI R <sub>jc</sub> = 1.1 K/W	90	90	GW6DGD50NFC	5000	1300	38.5	3744	74.8
					950	37	2880	81.9
		92	GW6DGD40NFC	4000	1300	38.5	3692	73.8
					950	37	2840	80.8
		93	GW6DGD30NFC	3000	1300	38.5	3536	70.6
					950	37	2720	77.4
			GW6DGD27NFC	2700	1300	38.5	3354	67.0
					950	37	2580	73.4

Type	CRI Ra		Part No.	CCT (K)	Current (mA)	Voltage (V)	Luminous Flux (lm)	Efficacy (lm/W)		
	Min.	Typ.								
25W - 40W Normal CRI Rjc = 1.6 K/W	80	82	GW6DMC60NFC	6000	1050	39	3780	92.3		
					700	37	2700	104.2		
			GW6DMC50NFC	5000	1050	39	3780	92.3		
					700	37	2700	104.2		
			GW6DMC40NFC	4000	1050	39	3710	90.6		
					700	37	2650	102.3		
		83	GW6DMC35NFC	3500	1050	39	3542	86.5		
					700	37	2530	97.7		
			GW6DMC30NFC	3000	1050	39	3430	83.8		
					700	37	2450	94.6		
			GW6DMC27NFC	2700	1050	39	3262	79.7		
					700	37	2330	90.0		
25W - 40W High CRI Rjc = 1.6 K/W	90	90	GW6DGC50NFC	5000	1050	39	3024	73.8		
					700	37	2160	83.4		
		92	GW6DGC40NFC	4000	1050	39	2968	72.5		
					700	37	2120	81.9		
		93	GW6DGC30NFC	3000	1050	39	2828	69.1		
					700	37	2020	78.0		
			GW6DGC27NFC	2700	1050	39	2688	65.6		
					700	37	1920	74.1		
25W - 40W 70 CRI Rjc = 1.6 K/W	67	70	GW6DAC60NFC	6000	1050	39	4200	102.6		
					700	37	3000	115.8		
					GW6DAC50NFC	4900	1050	39	4200	102.6
							700	37	3000	115.8
			GW6DAC40NFC	4000	1050	39	4172	101.9		
					700	37	2980	115.1		

 = Maximum Drive Current     = Typical Drive Current

Type	CRI Ra		Part No.	CCT (K)	Current (mA)	Voltage (V)	Luminous Flux (lm)	Efficacy (lm/W)		
	Min.	Typ.								
15W - 25W Normal CRI R <sub>jc</sub> = 2.3 K/W	80	82	GW6DMA60NFC	6000	700	40	2480	88.6		
					400	37	1600	108.1		
			GW6DMA50NFC	5000	700	40	2480	88.6		
					400	37	1600	108.1		
			GW6DMA40NFC	4000	700	40	2449	87.5		
					400	37	1580	106.8		
		83	GW6DMA35NFC	3500	700	40	2325	83.0		
					400	37	1500	101.4		
			GW6DMA30NFC	3000	700	40	2248	80.3		
					400	37	1450	98.0		
			GW6DMA27NFC	2700	700	40	2139	76.4		
					400	37	1380	93.2		
15W - 25W High CRI R <sub>jc</sub> = 2.3 K/W	90	90	GW6DGA50NFC	5000	700	40	2015	72.0		
					400	37	1300	87.8		
			GW6DGA40NFC	4000	700	40	1969	70.3		
					400	37	1270	85.8		
		93	GW6DGA30NFC	3000	700	40	1876	67.0		
					400	37	1210	81.8		
			GW6DGA27NFC	2700	700	40	1783	63.7		
					400	37	1150	77.7		
15W - 25W 70 CRI R <sub>jc</sub> = 2.3 K/W	67	70	GW6DAA60NFC	6000	700	40	2697	96.3		
					400	37	1740	117.6		
					GW6DAA50NFC	4900	700	40	2697	96.3
							400	37	1740	117.6
			GW6DAA40NFC	4000	700	40	2620	93.6		
					400	37	1690	114.2		

# The Mini Zenigata COB

Mini Zenigata COB LEDs offer an ideal solution for retail, restaurants, and other environments where the dazzling color rendering of the Mini Zenigata's 80 – 90 CRI specifications is desired. Mini Zenigata offers a luminous efficacy of up to 100 lm/W in standard operation, and a luminous flux greater than 2000 lm, for fantastic performance and brightness in a small footprint.

This year, Sharp introduces new 14W, 9W, and 6W Power Class products to bring you even more design flexibility. Plus, new in 2013, all Mini Zenigata LEDs have identical light emitting surface diameters, simplifying optical design across the different power classes.

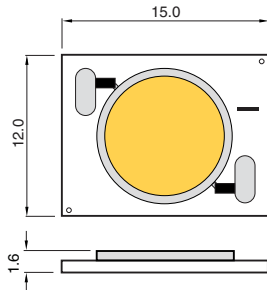

**NOTE:** Dimensions: mm  
Refer to Specifications for full dimensional information

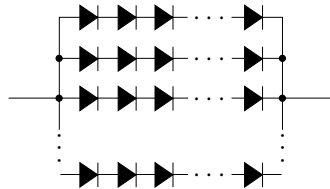

- 14W: (12 series × 5 parallel) = 60 LEDs
- 12W: (12 series × 4 parallel) = 48 LEDs
- 12W: (6 series × 8 parallel) = 48 LEDs
- 9W: (12 series × 3 parallel) = 36 LEDs
- 7W: (5 series × 6 parallel) = 30 LEDs
- 6W: (12 series × 2 parallel) = 24 LEDs

## Applications Include:

- Indoor and Outdoor Lighting
- Spotlights
- Reading Lamps
- Sign and Symbol Luminaires
- Mobile Lighting
- Pendant Lights
- Replacement Lamp (A19/PAR)

## MINI ZENIGATA

Type	CRI Ra		Part No.	CCT (K)	Current (mA)	Voltage (V)	Luminous flux (lm)	Efficacy (lm/W)	
	Min.	Typ.							
14W - 25W Normal CRI R <sub>jc</sub> = 2.7 K/W	80	82	GW6BMS50HED	5000	650	37.5	2055	84.3	
					400	36	1370	95.1	
			GW6BMS40HED	4000	650	37.5	2010	82.5	
					400	36	1340	93.1	
			GW6BMS30HED	3000	650	37.5	1875	76.9	
					400	36	1250	86.8	
	GW6BMS27HED	2700	650	37.5	1770	72.6			
			400	36	1180	81.9			
	14W - 25W High CRI R <sub>jc</sub> = 2.7 K/W	87	90	GW6BGS50HED	5000	650	37.5	1650	67.7
						400	36	1100	76.4
90		92	GW6BGS40HED	4000	650	37.5	1620	66.5	
					400	36	1080	75.0	
		93	GW6BGS30HED	3000	650	37.5	1560	64.0	
					400	36	1040	72.2	
		GW6BGS27HED	2700	650	37.5	1470	60.3		
				400	36	980	68.1		

Type	CRI Ra		Part No.	CCT (K)	Current (mA)	Voltage (V)	Luminous flux (lm)	Efficacy (lm/W)			
	Min.	Typ.									
12W - 19W Normal CRI Rjc = 3.1 K/W	80	82	GW6BMR50HED	5000	520	37	1639	85.2			
					320	36	1130	98.1			
			GW6BMR40HED	4000	520	37	1610	83.7			
					320	36	1110	96.4			
			GW6BMR30HED	3000	520	37	1494	77.6			
					320	36	1030	89.4			
			GW6BMR27HED	2700	520	37	1407	73.1			
					320	36	970	84.2			
			12W - 19W High CRI Rjc = 3.1 K/W	87	90	GW6BGR50HED	5000	520	37	1312	68.2
								320	36	905	78.6
90	92	GW6BGR40HED		4000	520	37	1291	67.1			
					320	36	890	77.3			
90	93	GW6BGR30HED		3000	520	37	1240	64.4			
					320	36	855	74.2			
90	93	GW6BGR27HED		2700	520	37	1167	60.7			
					320	36	805	69.9			

12W - 18W Normal CRI Rjc = 3.1 K/W	80	82	GW6BMJ50HED	5000	900	18.5	1495	89.8
					640	18	1150	99.8
			GW6BMJ40HED	4000	900	18.5	1456	87.4
					640	18	1120	97.2
			GW6BMJ30HED	3000	900	18.5	1352	81.2
					640	18	1040	90.3
			GW6BMJ27HED	2700	900	18.5	1287	77.3
					640	18	990	85.9

 = Maximum Drive Current  = Typical Drive Current

Type	CRI Ra		Part No.	CCT (K)	Current (mA)	Voltage (V)	Luminous flux (lm)	Efficacy (lm/W)
	Min.	Typ.						
9W - 15W Normal CRI Rjc = 3.9 K/W	80	82	GW6BMW50HED	5000	390	37	1247	86.4
					240	36	860	99.5
			GW6BMW40HED	4000	390	37	1218	84.4
					240	36	840	97.2
	GW6BMW30HED	3000	390	37	1131	78.4		
			240	36	780	90.3		
	GW6BMW27HED	2700	390	37	1073	74.4		
			240	36	740	85.6		
9W - 15W High CRI Rjc = 3.9 K/W	87	90	GW6BGW50HED	5000	390	37	1001	69.3
					240	36	690	79.9
	90	92	GW6BGW40HED	4000	390	37	972	67.3
					240	36	670	77.5
		93	GW6BGW30HED	3000	390	37	935	64.8
					240	36	645	74.7
	GW6BGW27HED	2700	390	37	892	61.8		
			240	36	615	71.2		
7W - 13W Normal CRI Rjc = 4.5 K/W	80	82	GW6BME50HED	5000	780	15.55	1044	86.1
					480	15	720	100.0
			GW6BME40HED	4000	780	15.55	1015	83.7
					480	15	700	97.2
	GW6BME30HED	3000	780	15.55	943	77.7		
			480	15	650	90.3		
	GW6BME27HED	2700	780	15.55	899	74.1		
			480	15	620	86.1		

 = Maximum Drive Current  = Typical Drive Current

Type	CRI Ra		Part No.	CCT (K)	Current (mA)	Voltage (V)	Luminous flux (lm)	Efficacy (lm/W)
	Min.	Typ.						
6W - 10W Normal CRI Rjc = 5.2 K/W	80	82	GW6BMG50HED	5000	260	37.5	834	85.5
					160	36	575	99.8
			GW6BMG40HED	4000	260	37.5	805	82.5
					160	36	555	96.4
			GW6BMG30HED	3000	260	37.5	754	77.3
					160	36	520	90.3
			GW6BMG27HED	2700	260	37.5	718	73.6
					160	36	495	85.9
6W - 10W High CRI Rjc = 5.2 K/W	87	90	GW6BGG50HED	5000	260	37.5	667	68.4
					160	36	460	79.9
	90	92	GW6BGG40HED	4050	260	37.5	645	66.2
					160	36	445	77.3
		93	GW6BGG30HED	3025	260	37.5	624	63.9
					160	36	430	74.7
		GW6BGG27HED	2700	260	37.5	595	61.0	
				160	36	410	71.2	

 = Maximum Drive Current     = Typical Drive Current

# The Petit Zenigata COB

## Tiny Footprint. Big Versatility.

Sharp's Petit Zenigata Chip on Board (COB) LED puts the many benefits of LED lighting technology at your fingertips for design of spot or track lighting solutions. The Petit's small footprint – just 8 mm x 12 mm – packs a big punch, with products in the High CRI line delivering between 300 – 395 lumens. Use fewer modules per fixture to alleviate heat issues and enjoy more design flexibility.

The 9.6V product allows a simple “buck” DC-DC converter to be used for MR16 lamps (which normally require 12V). Higher-voltage 40V parts provide an alternative to traditional line voltage in GU10 lamps.

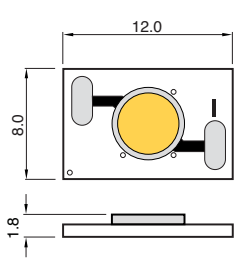

**NOTE:** Dimensions: mm  
Refer to Specifications for full dimensional information

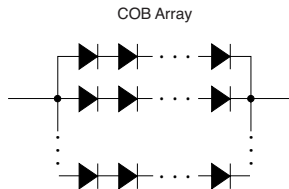

6W: (12 series x 1 parallel) = 12 LEDs  
5W: (3 series x 4 parallel) = 12 LEDs  
5W: (3 series x 3 parallel) = 9 LEDs  
4W: (3 series x 3 parallel) = 9 LEDs  
4W: (3 series x 2 parallel) = 6 LEDs

### Applications Include:

- Small Track and Spot Lights
- Small Accent Lights
- MR16 and GU10 Replacement Lamps
- Pendant Lights

## PETIT ZENIGATA

Type	CRI Ra		Part No.	CCT (K)	Current (mA)	Voltage (V)	Luminous flux (lm)	Efficacy (lm/W)			
	Min.	Typ.									
SMQ 6W Class Normal CRI Rjc = 11.5 C/W	80	82	GW5SMQ50P05	4850	160	40.9	495	75.6			
					140	40	450	80.4			
			GW5SMQ40P05	3950	160	40.9	495	75.6			
					140	40	450	80.4			
			GW5SMQ35P05	3400	160	40.9	462	70.6			
					140	40	420	75.0			
			GW5SMQ30P05	3000	160	40.9	462	70.6			
					140	40	420	75.0			
			GW5SMQ27P05	2730	160	40.9	429	65.6			
					140	40	390	69.6			
			SMD 5W Class Normal CRI Rjc = 11.5 C/W	80	82	GW5SMD50P05	4850	560	9.75	469	85.8
								500	9.6	430	89.6
GW5SMD40P05	3950	560				9.75	469	85.8			
		500				9.6	430	89.6			
GW5SMD35P05	3400	560				9.75	436	79.9			
		500				9.6	400	83.3			
GW5SMD30P05	3000	560				9.75	436	79.9			
		500				9.6	400	83.3			
GW5SMD27P05	2730	560				9.75	403	73.9			
		500				9.6	370	77.1			

 = Maximum Drive Current  = Typical Drive Current

Type	CRI Ra		Part No.	CCT (K)	Current (mA)	Voltage (V)	Luminous flux (lm)	Efficacy (lm/W)
	Min.	Typ.						
SGD 5W Class High CRI Rjc = 11.5 K/W	90	92	GW5SGD50P05	4850	560	9.75	391	71.5
					500	9.6	360	75.0
			GW5SGD40P05	3950	560	9.75	391	71.5
					500	9.6	360	75.0
			GW5SGD35P05	3400	560	9.75	358	65.6
					500	9.6	330	68.8
			GW5SGD30P05	3000	560	9.75	358	65.6
					500	9.6	330	68.8
			GW5SGD27P05	2730	560	9.75	326	59.6
					500	9.6	300	62.5

SMC 4W Class Normal CRI Rjc = 16 K/W	80	82	GW5SMC50P05	4850	460	9.95	352	76.9
					400	9.8	320	81.6
			GW5SMC40P05	3950	460	9.95	352	76.9
					400	9.8	320	81.6
			GW5SMC35P05	3400	460	9.95	330	72.1
					400	9.8	300	76.5
			GW5SMC30P05	3000	460	9.95	330	72.1
					400	9.8	300	76.5
			GW5SMC27P05	2730	460	9.95	308	67.3
					400	9.8	280	71.4

Type	CRI Ra		Part No.	CCT (K)	Current (mA)	Voltage (V)	Luminous flux (lm)	Efficacy (lm/W)
	Min.	Typ.						
5W Class Normal CRI Rjc = 9.3 C/W	80	82	GW5SMC60P0C	6000	560	10.4	451	77.4
					500	10.3	410	79.6
			GW5SMC50P0C	5000	560	10.4	451	77.4
					500	10.3	410	79.6
			GW5SMC40P0C	4000	560	10.4	440	75.5
					500	10.3	400	77.7
	GW5SMC30P0C	3000	560	10.4	418	71.8		
			500	10.3	380	73.8		
	GW5SMC27P0C	2700	560	10.4	385	66.1		
			500	10.3	350	68.0		

4W Class Normal CRI Rjc = 9.3 C/W	80	82	GW5SMB60P0C	6000	380	10.4	322.4	81.6
					350	10.3	310	86.0
			GW5SMB50P0C	5000	380	10.4	322.4	81.6
					350	10.3	310	86.0
			GW5SMB40P0C	4000	380	10.4	312	78.9
					350	10.3	300	83.2
	GW5SMB30P0C	3000	380	10.4	291.2	73.7		
			350	10.3	280	77.7		
	GW5SMB27P0C	2700	380	10.4	270.4	68.4		
			350	10.3	260	72.1		

 = Maximum Drive Current     = Typical Drive Current

# The Double Dome

## Sharp's Linear Lighting Solution

Sharp's specialty Double Dome LED family provides a high-intensity white LED option for area and strip lighting solutions. Its moderate light output cuts down on potential glare compared to higher-wattage LEDs, and a small surface-mountable footprint provides ease of installation.

The one-die Double Dome offers an energy-saving option for very subtle applications, and an LED alternative for "tube-style" lighting (e.g., fluorescent tubes). Two-die Double Domes create elegant lighting for solutions with medium brightness, and the three-die product achieves higher lumen output for maximum brightness.

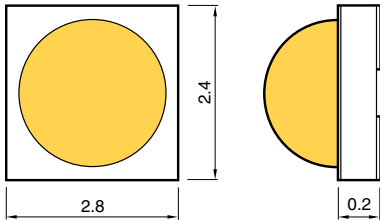

**NOTE:** Dimensions: mm  
*Refer to Specifications for full dimensional information*

### Applications Include

- Strip Lighting
- Accent and Edge Lighting
- Back Lighting
- Refrigerator Case Lighting
- Channel Letter Solutions

## DOUBLE DOME

Type	CRI Ra		Part No.	CCT (K)	Current (mA)	Voltage (V)	Luminous flux (lm)	Efficacy (lm/W)
	Min.	Typ.						
Double Dome 0.5W (3 dice) Rjc = 25 K/W	80	83	GM2BB65QK0C	6500	220	3.07	68.5	101
					150	2.95	50	113
			GM2BB57QK0C	5700	220	3.07	71	105
					150	2.95	52	118
			GM2BB50QK0C	5000	220	3.07	72.5	107
					150	2.95	53	120
			GM2BB45QK0C	4500	220	3.07	70	104
					150	2.95	51	115
			GM2BB40QK0C	4000	220	3.07	68.5	101
					150	2.95	50	113
			GM2BB35QK0C	3500	220	3.07	66	98
					150	2.95	48	108
			GM2BB30QK0C	3000	220	3.07	63	93
					150	2.95	46	104
			GM2BB27QK0C	2700	220	3.07	60.5	90
					150	2.95	44	99

 = Maximum Drive Current  = Typical Drive Current

Type	CRI Ra		Part No.	CCT (K)	Current (mA)	Voltage (V)	Luminous flux (lm)	Efficacy (lm/W)
	Min.	Typ.						
Double Dome 0.3W (2 dice) R <sub>jc</sub> = 33 K/W	80	83	GM2BB65QKAC	6500	160	3.07	50.3	102
					100	2.95	33.5	114
					80	2.90	27.5	119
			GM2BB57QKAC	5700	160	3.07	52.5	107
					100	2.95	35.0	119
					80	2.90	29.0	125
			GM2BB50QKAC	5000	160	3.07	53.3	108
					100	2.95	35.5	120
					80	2.90	29.5	127
			GM2BB45QKAC	4500	160	3.07	51.8	105
					100	2.95	34.5	117
					80	2.90	28.5	123
			GM2BB40QKAC	4000	160	3.07	50.3	102
					100	2.95	33.5	114
					80	2.90	27.5	119
			GM2BB35QKAC	3500	160	3.07	48.8	99
					100	2.95	32.5	110
					80	2.90	27.0	116
			GM2BB30QKAC	3000	160	3.07	46.5	95
					100	2.95	31.0	105
					80	2.90	25.5	110
			GM2BB27QKAC	2700	160	3.07	44.3	90
					100	2.95	29.5	100
					80	2.90	24.5	106

Type	CRI Ra		Part No.	CCT (K)	Current (mA)	Voltage (V)	Luminous flux (lm)	Efficacy (lm/W)
	Min.	Typ.						
Double Dome 0.2W (1 die) Rjc = 65 K/W	80	83	GM2BB65QK1C	6500	100	3.10	31.5	102
					70	3.04	23.1	109
					50	2.95	17.5	119
			GM2BB57QK1C	5700	100	3.10	33.3	107
					70	3.04	24.5	115
					50	2.95	18.5	125
			GM2BB50QK1C	5000	100	3.10	33.3	107
					70	3.04	24.5	115
					50	2.95	18.5	125
			GM2BB45QK1C	4500	100	3.10	32.0	103
					70	3.04	23.5	110
					50	2.95	17.8	121
			GM2BB40QK1C	4000	100	3.10	31.5	102
					70	3.04	23.1	109
					50	2.95	17.5	119
			GM2BB35QK1C	3500	100	3.10	30.2	98
					70	3.04	22.2	104
					50	2.95	16.8	114
			GM2BB30QK1C	3000	100	3.10	29.0	93
					70	3.04	21.3	100
					50	2.95	16.1	109
			GM2BB27QK1C	2700	100	3.10	27.7	89
					70	3.04	20.4	96
					50	2.95	15.4	104

 = Maximum Drive Current     = Typical Drive Current

# The Color of Life

Life happens in full spectrum. Lighting for many applications – retail, hospitality, architectural, and home are just a few examples – needs to be more than just functional and reliable; it must accurately illuminate the dazzling colors that shape our world, and make objects, people, and places look their absolute best.

Sharp LEDs bring you some of the most true-to-life color rendering available. Products in our Mega Zenigata High CRI line boast up to 93 CRI, meeting or exceeding the ENERGY STAR® minimum requirement (80 CRI).

Still, we recognize that CRI measurement alone is not enough. Sharp LEDs go beyond typical CRI measurements (R1 – R8) with powerful performance up to R15. This includes excellent R9 (deep red) rendering. Accurate, deep reds lend a warm, vibrant aesthetic that will help elevate your lighting products from “efficient” to “unforgettable.”

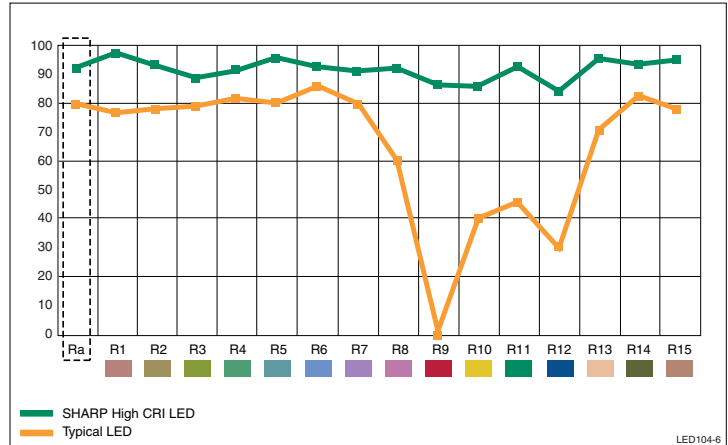



## Support

Sharp makes more than 40 years of LED know-how available when you need it most. Our U.S.-based support team includes experts located in your region who can help save you valuable time in the lab and get to market more quickly. Have questions? Sharp answers.

## Learn More

Contact your local Sharp representative or Distributor for more information or product samples – or visit [www.SharpLEDs.com](http://www.SharpLEDs.com). Our Resources page will lead you to whitepapers, application notes, Podcasts, product specifications, and information about third party support for reflectors, lenses, and holders.

# A Brighter Environmental Outlook

The benefits of LED lighting not only brighten your design; they brighten our world. LEDs are free of hazardous substances such as mercury (Hg). They convert energy to visible light much more efficiently than traditional lighting sources. Plus, an increased operating life (Sharp's modules typically exceed 50k hours of operation, versus a typical 10k hours for a compact fluorescent and 2k hours for an incandescent bulb) means a longer time before LEDs require replacement.



## HEADQUARTERS

5700 NW Pacific Rim Blvd.  
Camas, WA 98607, U.S.A.  
Phone: (1) 360-834-2500  
Fax: (1) 360-834-8903  
www.sharpsma.com

## WESTERN REGION

1980 Zanker Road  
San Jose, CA 95112  
Phone: (1) 408-436-4900  
Fax: (1) 408-436-0924

4 Hutton Center, Suite 800  
Santa Ana, CA 92707  
Phone: (1) 657-235-3779  
Fax: (1) 657-235-3780

## EASTERN REGION

200 Wheeler Rd.  
Burlington, MA 01803  
Phone: (1) 781-270-7979  
Fax: (1) 781-229-9117

8000 Regency Parkway, Suite 280  
Cary, NC 27518  
Phone: (1) 919-460-0695  
Fax: (1) 919-460-0795

85 W. Algonquin Road, Suite 280  
Arlington Heights, IL 60005  
Phone: (1) 847-258-2750  
Fax: (1) 847-439-2479

One Towne Square, Suite 200  
Southfield, MI 48076  
Phone: (1) 248-663-5720  
Fax: (1) 248-663-5750