

## ■ Oscillation Circuits

The following circuit diagrams are examples of the oscillation circuits recommended when crystal units are used. After determining your frequency range and overtone specifications, you can then establish various circuit elements and conditions depending on the choice of either an IC circuit or discrete

transistor.

IC circuit constants or circuit configurations vary among the different IC manufactures and such factors may have a subtle effect upon the oscillation of a quartz crystal unit.

For further details, please contact us.

**1. Frequency Range : 12 to 20 MHz**  
**Overtone Order : Fundamental**  
**Load Capacitance  $C_L = 20$  pF**

Crystal oscillation circuits for PLL

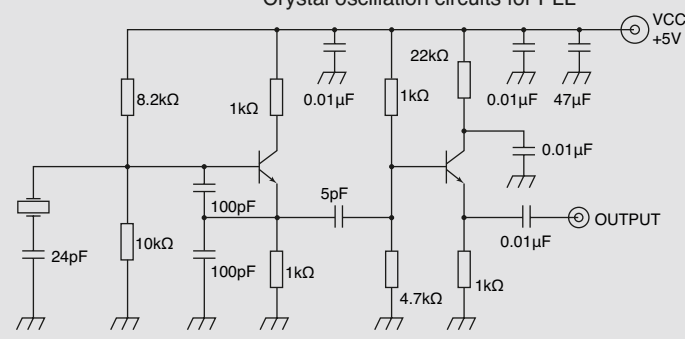

**2. Frequency Range : 3 to 25 MHz**  
**Overtone Order : Fundamental**

Frequency Range(MHz)	$C1=C2$ (pF)	$R1$ (Ω)	Load Capacitance(pF)
3 to 4	33	4.7 k	20
4 to 5	33	3.3 k	20
5 to 6	33	2.2 k	20
6 to 9	22	1.0 k	16
9 to 10	22	470	16
10 to 15	15	470	12
15 to 20	15	470	12
20 to 25	10	470	10

74HCU04AP

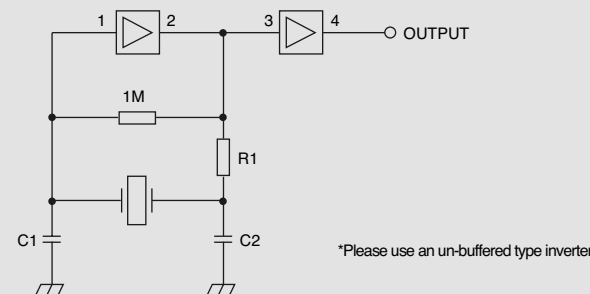

**3. Frequency Range : 3 to 25 MHz**  
**Overtone Order : Fundamental**

Frequency Range(MHz)	$C1=C2$ (pF)	$R1$ (Ω)	Load Capacitance(pF)
3 to 4	33	6.8 k	20
4 to 5	33	4.7 k	20
5 to 6	33	3.3 k	20
6 to 9	22	2.2 k	16
9 to 10	22	1.0 k	16
10 to 15	15	470	12
15 to 20	10	330	12
20 to 25	7	330	10

7SU04F      7SU04F

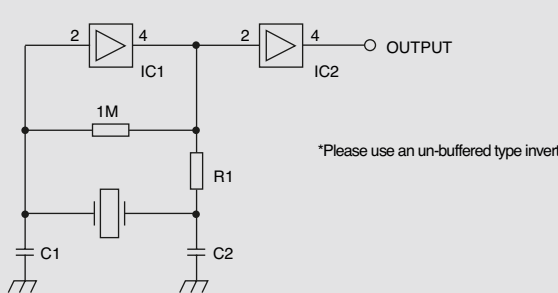

**4. Frequency Range : 25 to 50MHz**  
**Overtone Order : Fundamental**

Frequency Range(MHz)	$C1=C2$ (pF)	$R1$ (Ω)	Load Capacitance(pF)
25 to 30	15	1.0 k	12
30 to 40	10	680	10
40 to 50	7	330	8

7SHU04      7SHU04

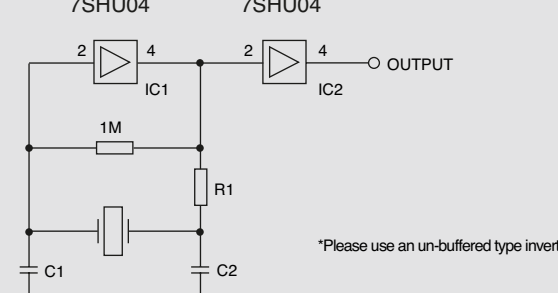

## ■ Oscillation Circuits

**5. Frequency Range : 30 to 60 MHz**  
**Overtone Order : 3rd overtone**

Frequency Range (MHz)	C1(pF)	C2(pF)	L1(μH)	R1(Ω)	Load Capacitance (pF)
3.0 to 4.0	10	18 to 10	2.2	820	10
4.0 to 5.0	7	15 to 10	1.5	470	8
5.0 to 6.0	5	15 to 10	1.0	330	8

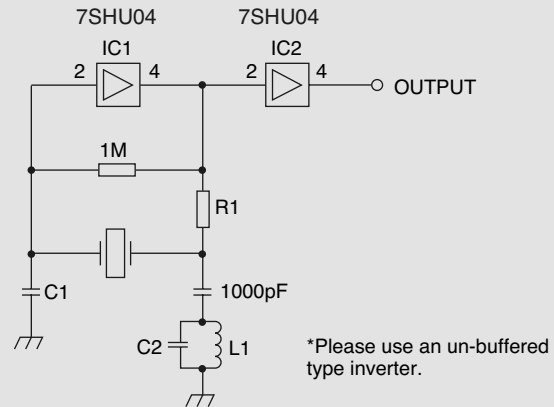

**6. Frequency Range : 16 to 80 MHz max**  
**Overtone Order : 3rd, 5th overtone**  
**Load Capacitance CL : Series resonance**

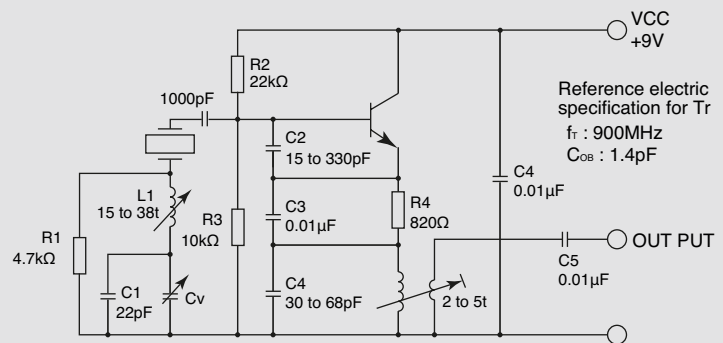

**7. Frequency Range : 80 to 140 MHz max**  
**Overtone Order : 3rd, 5th overtone**  
**Load Capacitance CL : Series resonance**

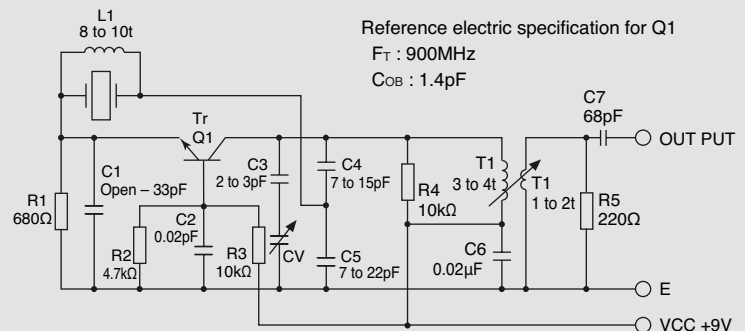

## ■ Oscillation Circuits

### 8. Example of Un-buffered IC Oscillation Circuit Connection

To prevent coupling between input and output:

- Position input pin 3 at a distance from output pin 7.
- Inactivate the inverter at the center.

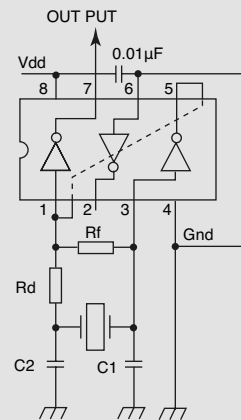

$R_f=1M\Omega$   
 $R_d=100$  to  $10k\Omega$   
 $C_1, C_2=5$  to  $33pF$

### 9. Example of IC Internal Oscillation Circuit Connection

To achieve correct operation:

- When IC has Resistance  $R_1$  already embedded, its mounting is unnecessary.
- Resistance  $R_2$  is necessary for the prevention of abnormal oscillation.
- Use this circuitry as the base pattern.
- Install Resistance  $R_2$  on to the output side after checking the IC terminal function.

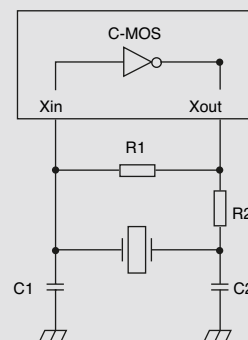

$R_1=1M\Omega$   
 $R_2=100$  to  $10k\Omega$   
 $C_1, C_2=5$  to  $33pF$

Note for Mounting:

1. Use the shortest distance for lines connecting parts, including ground lines, in order to prevent the inclusion of unnecessary stray capacitance.
2. Do not allow any part of the oscillation circuit to cross over a signal line of any other circuit on the same circuit board.