



# SiC Power Devices and Modules

Application Note

Rev.001  
Issue of June 2013

13103EAY01

# Contents

---

1. SiC Semiconductors.....	3
1.1 Property of SiC material.....	3
1.2 Advantages of SiC material for power device applications.....	3
2. Characteristics of SiC Schottky Barrier Diode (SBD) .....	5
2.1 Device structure and characteristics .....	5
2.2 Forward characteristics of SiC-SBD .....	5
2.3 Reverse recovery characteristics of SiC-SBD.....	6
3. Characteristics of SiC-MOSFET .....	8
3.1 Device structure and characteristics .....	8
3.2 Specific on-resistance.....	9
3.3 Vd-Id characteristics.....	10
3.4 Gate voltage Vgs to drive SiC-MOSFET and Rdson .....	10
3.5 Vg-Id characteristics.....	11
3.6 Turn-on characteristics.....	12
3.7 Turn-off characteristics.....	13
3.8 Internal gate resistance.....	14
3.9 Gate drive circuit .....	15
3.10 Forward characteristics of body diode and reverse conduction.....	15
3.11 Reverse recovery characteristics of body diode.....	17
4. Characteristics of SiC power modules.....	18
4.1 Characteristics of SiC power module.....	18
4.2 Topologies.....	18
4.3 Switching characteristics.....	19
4.3.1 Id and Tj dependencies of switching characteristics .....	19
4.3.2 Gate resistance dependency of switching characteristics .....	20
4.3.3 Gate voltage dependency of switching characteristics .....	21
4.4 Comparison of switching loss with Si-IGBT power modules .....	22
4.4.1 Comparison of total switching loss with Si-IGBT power modules.....	22
4.4.2 Comparison of diode reverse recovery loss (Err) with Si-IGBT power modules ...	22
4.4.3 Comparison of turn-on loss (Eon) with Si-IGBT .....	23
4.4.4 Comparison of turn-off loss (Eoff) with Si-IGBT power modules .....	24
5. Reliability of SiC-SBD .....	25
5.1 dV/dt and dI/dt break-down .....	25
5.2 Results of SiC-SBD reliability tests .....	25
6. Reliability of SiC-MOSFET.....	26
6.1 Reliability of gate insulating layer.....	26

6.2	Stability of gate threshold voltage against positive gate voltage.....	27
6.3	Stability of gate threshold voltage against negative gate voltage.....	27
6.4	Reliability of body diodes.....	28
6.5	Short circuit safe operation area .....	29
6.6	dV/dt breakdown.....	30
6.7	Neutron-induced single event burnout .....	30
6.8	Electrostatic discharge withstand capability.....	30
6.9	Results of SiC-MOSFET reliability tests .....	31
7.	Instructions to use SiC power modules and their reliability.....	32
7.1	Measures to reduce surge voltage .....	32
7.2	Bridge arm short circuit by self turn-on.....	32
7.3	RBSOA (Reverse bias safe operating area).....	33
7.4	Results of SiC power module reliability tests .....	34
8.	Definition of part number.....	35
8.1	SiC-SBD (discrete components).....	35
8.2	SiC-MOSFET (discrete components).....	35
8.3	SiC Power Modules .....	36
8.4	SiC-SBD (bare dice).....	36
8.5	SiC-MOSFET (bare dice) .....	36
9.	Examples of applications and benefits of using SiC .....	37
9.1	Power factor correction (PFC) circuits (CCM - Continuous conduction mode).....	37
9.2	Solar inverters .....	37
9.3	DC/DC converters .....	37
9.4	Bi-directional converters .....	38
9.5	Inverters for induction heating equipment .....	38
9.6	Motor drive inverters.....	38
9.7	Buck converters.....	39

# 1. SiC Semiconductors

## 1.1 Property of SiC material

SiC (Silicon Carbide) is a compound semiconductor comprised of silicon (Si) and carbon (C). Compared to Si, SiC has ten times the dielectric breakdown field strength, three times the bandgap, and three times the thermal conductivity. Both p-type and n-type regions, which are necessary to fashion device structures in a semiconductor materials, can be formed in SiC. These properties make SiC an attractive material from which to manufacture power devices that can far exceed the performance of their Si counterparts. SiC devices can withstand higher breakdown voltage, have lower resistivity, and can operate at higher temperature.

SiC exists in a variety of polymorphic crystalline structures called polytypes e.g., 3C-SiC, 6H-SiC, 4H-SiC. Presently 4H-SiC is generally preferred in practical power device manufacturing. Single-crystal 4H-SiC wafers of 3 inches to 6 inches in diameter are commercially available.

Properties	Si	4H-SiC	GaAs	GaN
Crystal Structure	Diamond	Hexagonal	Zincblende	Hexagonal
Energy Gap : $E_G$ (eV)	1.12	3.26	1.43	3.5
Electron Mobility : $\mu_n$ ( $\text{cm}^2/\text{Vs}$ )	1400	900	8500	1250
Hole Mobility : $\mu_p$ ( $\text{cm}^2/\text{Vs}$ )	600	100	400	200
Breakdown Field : $E_B$ (V/cm) $\times 10^6$	0.3	3	0.4	3
Thermal Conductivity (W/cm $^\circ\text{C}$ )	1.5	4.9	0.5	1.3
Saturation Drift Velocity : $v_s$ (cm/s) $\times 10^7$	1	2.7	2	2.7
Relative Dielectric Constant : $\epsilon_s$	11.8	9.7	12.8	9.5
p, n Control	○	○	○	△
Thermal Oxide	○	○	×	×

**Table 1**

## 1.2 Advantages of SiC material for power device applications

With dielectric breakdown field strength approximately 10 times higher than that of Si. SiC devices can be made to have much thinner drift layer and/or higher doping concentration, i.e., they have very high breakdown voltage (600V and up) and yet with very low resistance relative to silicon devices. Resistance of high-voltage devices is predominantly determined by the width of the drift region. In theory, SiC can reduce the resistance per unit area of the drift layer to 1/300 compared to Si at the same breakdown voltage.

The most popular silicon power devices for high-voltage, high-current applications are IGBT (Insulated Gate Bipolar Transistors). With IGBTs, low resistance at high breakdown voltage is achieved at the cost of switching performance. Minority carriers are injected into the drift region to reduce conduction (on-) resistance. When the transistor is turned off, it takes time for these carrier recombine and “dissipate”, thus increasing switching loss and time. In contrast, MOSFETs are majority carrier devices. Taking

advantages of SiC's higher breakdown field and higher carrier concentration, SiC MOSFET thus can combine all three desirable characteristics of power switch, i.e., high voltage, low on-resistance, and fast switching speed.

The larger bandgap also means SiC devices can operate at higher temperatures. The guaranteed operating temperature of current SiC devices is from 150°C - 175°C. This is due mainly to thermal reliability of packages. When properly packaged, they can operate at 200°C and higher.

# 2. Characteristics of SiC Schottky Barrier Diode (SBD)

## 2.1 Device structure and characteristics

SiC SBDs (Schottky barrier diodes) with breakdown voltage from 600V (which far exceeds the upper limit for silicon SBDs) and up are readily available. Compared to silicon FRDs (fast recovery diodes), SiC SBDs have much lower reverse recovery current and recovery time, hence dramatically lower recovery loss and noise emission. Furthermore, unlike silicon FRDs, these characteristics do not change significantly over current and operating temperature ranges. SiC SBDs allow system designers to improve efficiency, lower cost and size of heat sink, increase switching frequency to reduce size of magnetics and its cost, etc.

SiC-SBDs are increasingly applied to circuits such as power factor correctors (PFC) and secondary side bridge rectifier in switching mode power supplies. Today’s applications are air conditioners, solar power conditioners, EV chargers, industrial equipment and so on.

ROHM’s current SiC SBD lineup includes 600V and 1,200V; amperage rating ranges from 5A to 40A. 1,700V devices are under development.

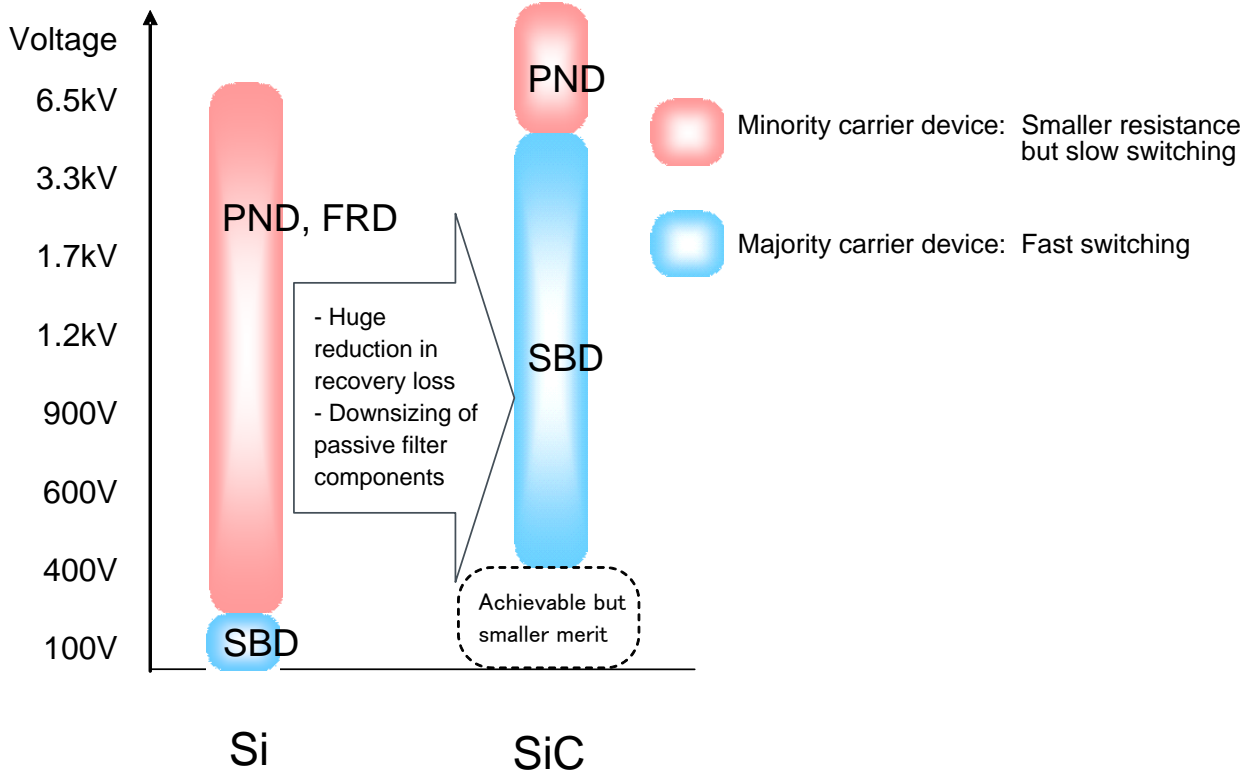


Figure 1

## 2.2 Forward characteristics of SiC-SBD

SiC-SBDs have similar threshold voltage as Si-FRDs, i.e., a little less than 1V. Threshold voltage is determined by Schottky barrier height. Normally, a low barrier height corresponds with low threshold voltage and high reverse leakage current. In its second-generation SBDs, Rohm has improved the

process to reduce threshold voltage by about 0.15V while maintaining the leakage current and recovery performance. Unlike Si-FRDs,  $V_f$  increases with temperature. SiC SBDs have positive temperature coefficient and thus will not cause thermal runaway when used in parallel.

Forward Characteristics of 600V 10A SiC-SBD

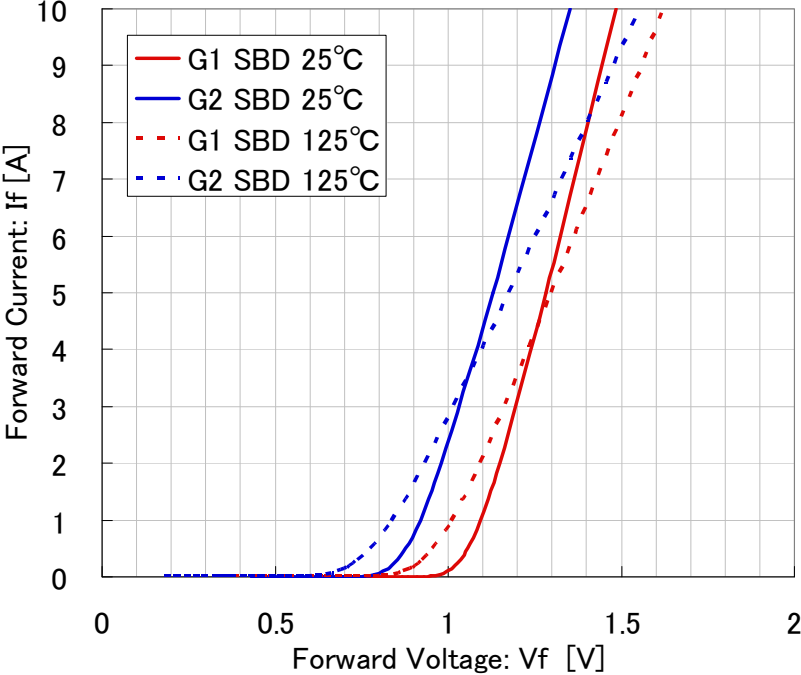


Figure 2

2.3 Reverse recovery characteristics of SiC-SBD

Si fast P-N junction diodes (e.g. FRDs: fast recovery diodes) have high transient current at the moment the junction voltage switches from the forward to the reverse direction, resulting in significant switching loss. This is due to minority carriers stored in the drift layer during conduction phase when forward voltage is applied. The higher the forward current (or temperature), the longer the recovery time and the larger the recovery current.

In contrast, since SiC-SBDs are majority carrier (unipolar) devices that use no minority carriers for electrical conduction, they do not store minority carriers. The reverse recovery current in SiC SBDs is only to discharge junction capacitance. Thus the switching loss is substantially lower compared to that in Si-FRDs. The transient current is nearly independent of temperatures and forward currents, and thereby achieves stable fast recovery in any environment. This also means SiC-SBDs generate less noise from the recovery current.

Reverse Recovery Waveform (600V 10A)

Temperature Dependency

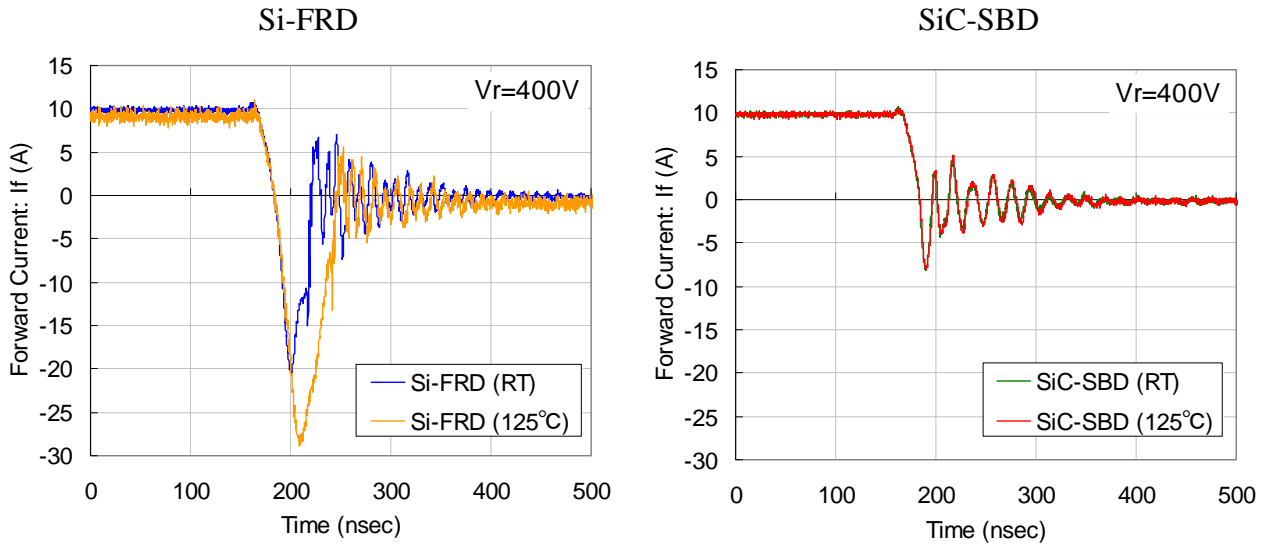


Figure 3

Forward Current Dependency

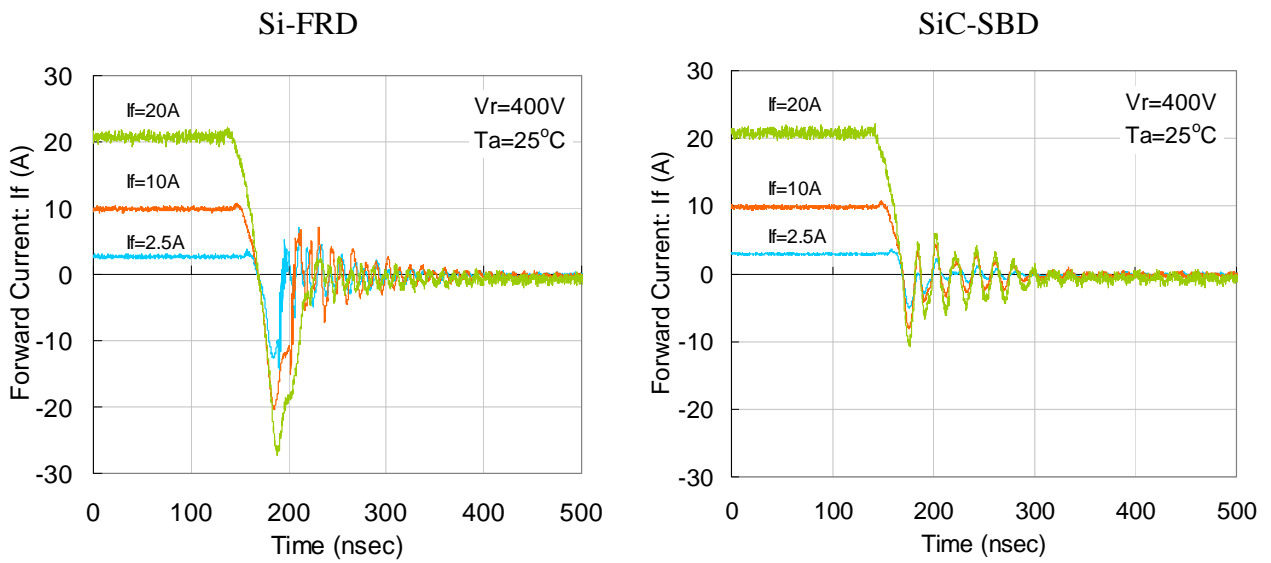


Figure 4

### 3. Characteristics of SiC-MOSFET

#### 3.1 Device structure and characteristics

Si power devices with higher breakdown voltages have considerably high on-resistance per unit area, which increases approximately by the 2nd to 2.5th power of the breakdown voltage. As a result, IGBTs (Insulated Gate Bipolar Transistors) have been mainly used in devices with breakdown voltages of 600V or higher. IGBTs achieve lower on-resistance than MOSFETs by injecting minority carriers into the drift region, a phenomenon called conductivity modulation. These minority carriers generate tail current when transistors are turned off, resulting in a significant switching loss.

SiC devices do not need conductivity modulation to achieve low on-resistance since they have much lower drift-layer resistance than Si devices. MOSFETs generate no tail current in principle. As a result, SiC MOSFETs have much lower switching loss than IGBTs, which enables higher switching frequency, smaller passives, smaller and less expensive cooling system. Compared to 600V-900V silicon MOSFETs, SiC MOSFETs have smaller chip area (mountable on a compact package) and an ultralow recovery loss of body diodes. For these reasons, SiC-MOSFETs are increasingly being used in power supplies for industrial equipments and inverters/converters for high-efficiency power conditioners.

ROHM's current lineup includes 650V and 1,200V planar type MOSFETs. 1,700V MOSFETs are under development.

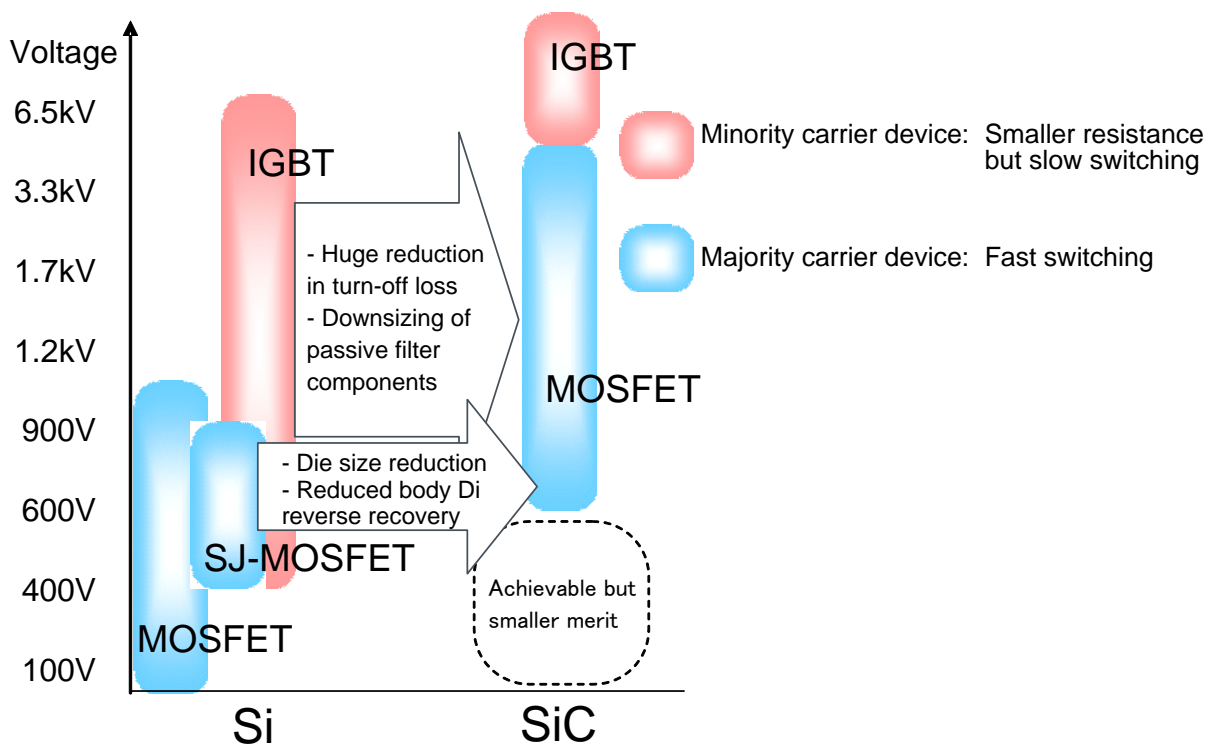


Figure 5

### 3.2 Specific on-resistance

Since SiC has dielectric breakdown field strength 10 times higher than that of Si, high breakdown voltage devices can be achieved with a thin drift layer with high doping concentration. This means, at the same breakdown voltage, SiC devices have quite low specific on-resistance (on-resistance per unit area). For example, 900V SiC-MOSFET can provide the same on-resistance as Si-MOSFETs and Si super junction MOSFETs with a chip size 35 times and 10 times respectively smaller. Smaller chip size reduces gate charge  $Q_g$  and capacitance.

Existing Si super junction MOSFETs are only available for breakdown voltages up to around 900V. SiC-MOSFETs have breakdown voltages up to 1,700V or higher with low on-resistance.

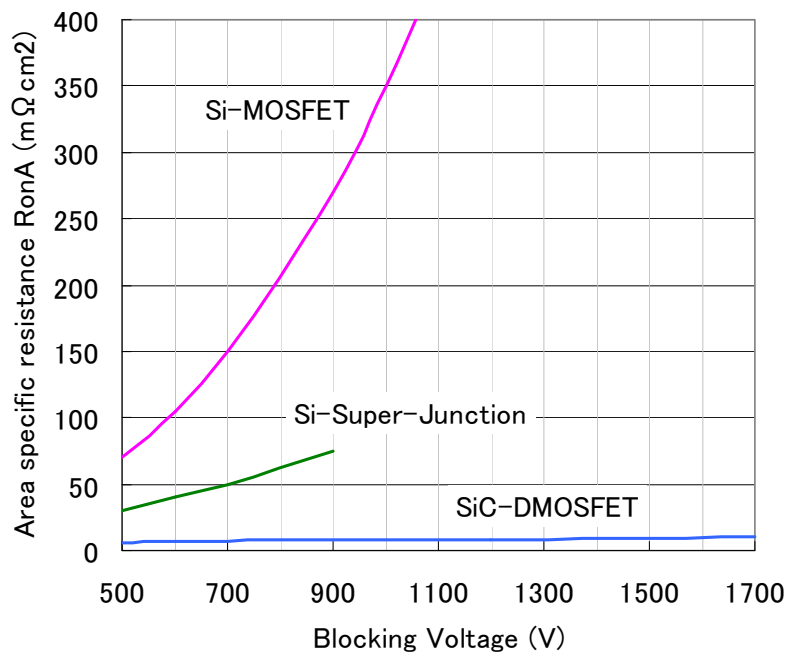


Figure 6

### 3.3 Vd-Id characteristics

Since SiC-MOSFETs have no threshold voltage (knee) as IGBTs, they have a low conduction loss over wide current range.

Si-MOSFETs' on-resistance at 150°C is more than twice that at room temperature, whereas SiC-MOSFETs' on-resistance increases only at a relatively low rate. This facilitates thermal design for SiC-MOSFETs and provides low on-resistance at high temperatures.

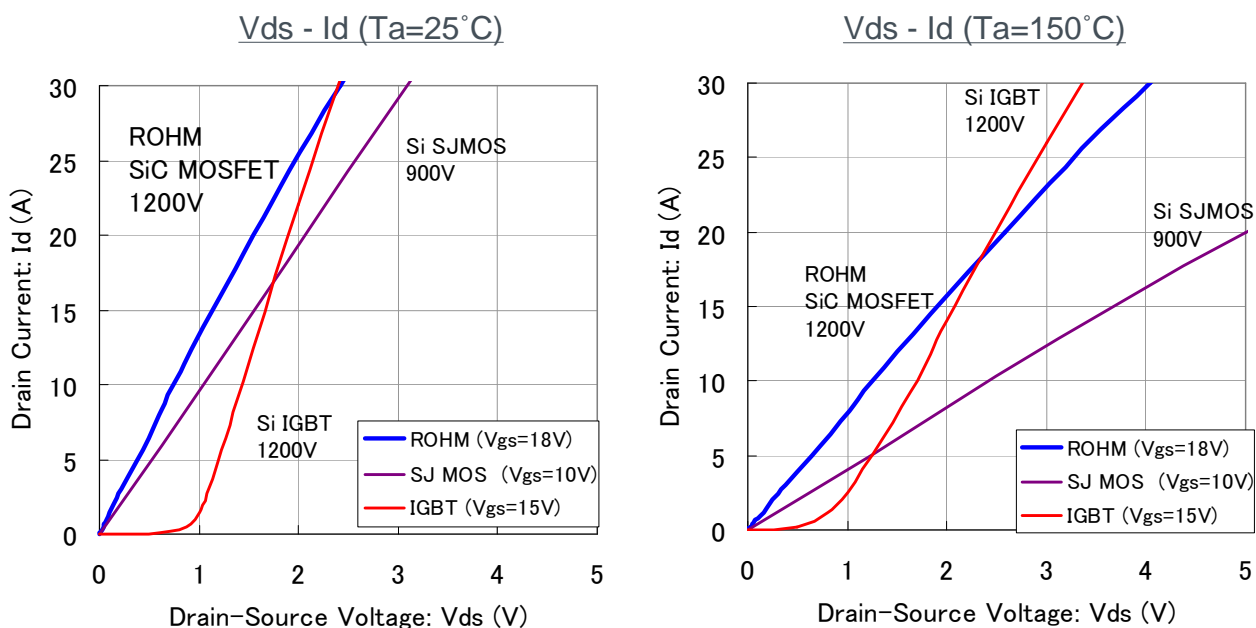


Figure 7

※These data are provided to show a result of evaluation done by ROHM for your reference. ROHM does not guarantee any of the characteristics shown here.

### 3.4 Gate voltage Vgs to drive SiC-MOSFET and Rds(on)

Although SiC-MOSFETs have lower drift layer resistance than Si-MOSFETs, the lower carrier mobility in SiC means their channel resistance is higher. For this reason, the higher the gate voltage, the lower the on-resistance. Resistance becomes progressively saturated as Vgs gets higher than 20V. SiC-MOSFETs do not exhibit low on-resistance with the gate voltage Vgs of 10 to 15V which is applied to typical IGBTs and Si-MOSFETs. It is recommended to drive SiC-MOSFETs with Vgs set to 18V in order to obtain adequately low on-resistance.

Please be advised not to use SiC-MOSFETs with Vgs below 13V as doing so may cause thermal runaway.

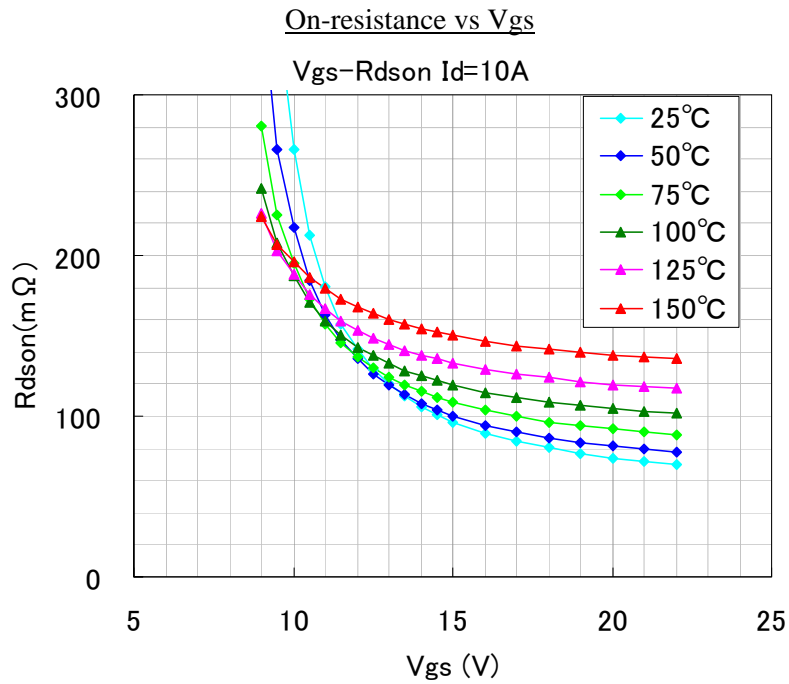


Figure 8

### 3.5 Vg-Id characteristics

The threshold voltage of SiC-MOSFET is about the same as Si-MOSFET's, i.e., approximately 3V at room temperature (normally OFF) at a few mA. However, since approximately 8V or more of gate voltage is required to conduct several amperes of current, SiC-MOSFET can be said to have higher noise immunity than IGBT to accidental turn-on. The threshold voltage decreases with increasing temperature.

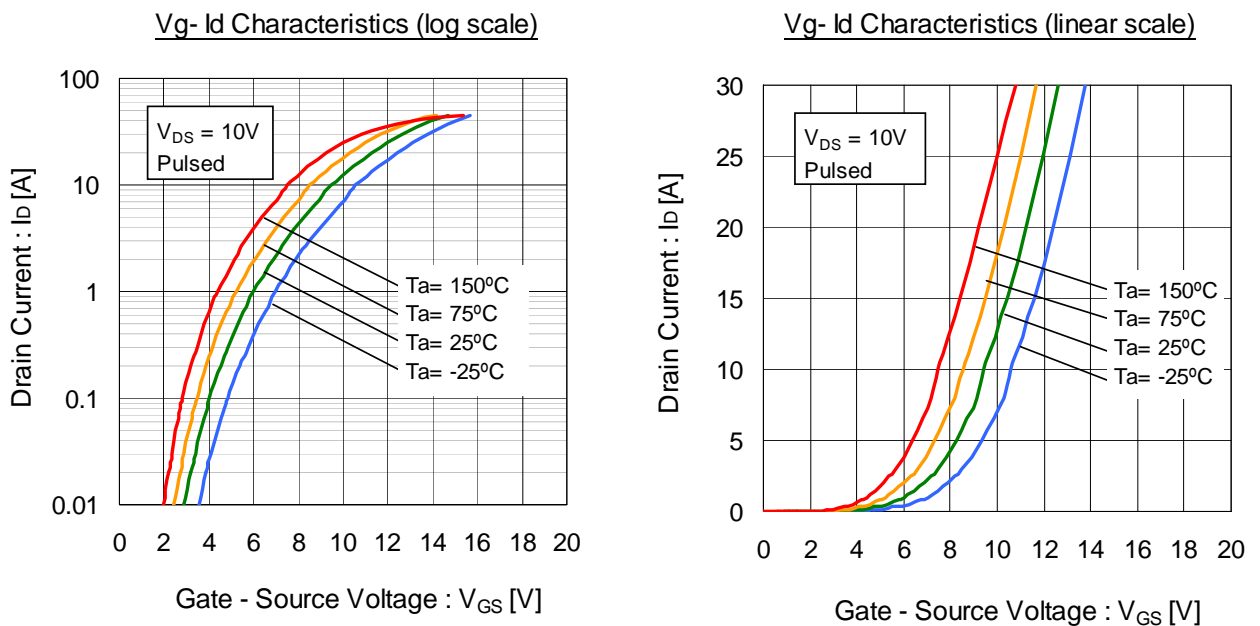


Figure 9

### 3.6 Turn-on characteristics

The double-pulse clamped inductive load test setup below is used to compare switching performance of two half-bridge circuits. One half bridge uses Rohm's SCH2080KE SiC-MOSFET co-packaged with SiC-SBD; the other uses a Si-IGBT co-packaged with Si-FRD.

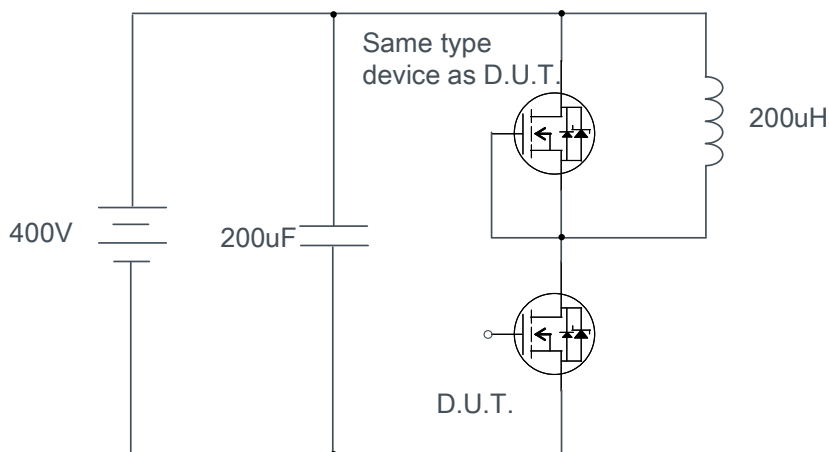


Figure 10

The turn-on switching rate of SiC-MOSFET is several tens of nanoseconds, which is equivalent to that of Si-IGBT and Si-MOSFET. However, inductive load switching causes a recovery current from commutation to the upper arm diodes to pass through the lower arm.

Si-FRDs and Si-MOSFET body diodes normally have exceedingly high recovery current, resulting in heavy losses. Furthermore, these losses tend to worsen at high temperature. In contrast, SiC-SBDs have low recovery current and short recovery time which are fairly independent of temperature. SiC-MOSFET's body diode has recovery performance equivalent to that of discrete SiC-SBDs, but it has higher  $V_f$ . This fast recovery performance of diodes reduces turn on loss ( $E_{on}$ ) by several tens of percentages.

The switching rate depends largely on the external gate resistance  $R_g$ . For fast switching, it is recommended to use a small gate resistor of several ohms. The selection of appropriate gate resistance must take surge voltage into account.

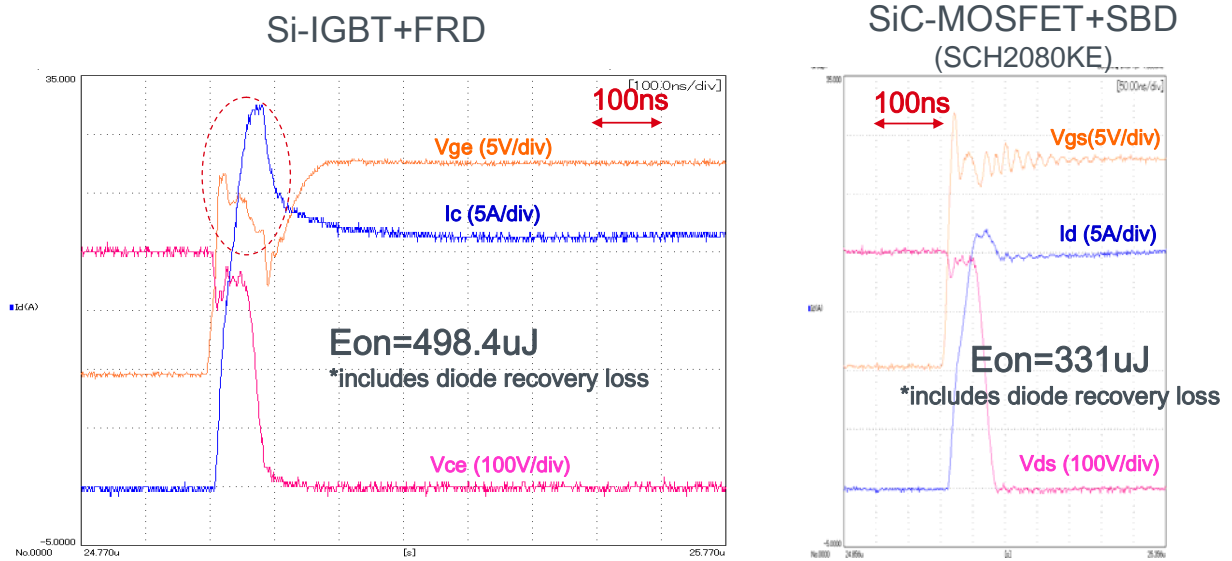


Figure 11

※These data are provided to show a result of evaluation done by ROHM for your reference. ROHM does not guarantee any of the characteristics shown here.

### 3.7 Turn-off characteristics

The most distinctive feature of SiC-MOSFETs is that they do not exhibit tail currents as observed in IGBTs. Therefore SiC MOSFETs can have turn off loss ( $E_{off}$ ) that is approximately 90% smaller. IGBT's tail current increases with temperature whereas switching characteristics of MOSFETs are nearly independent of temperature. IGBT's high switching loss increases the chip's junction temperature ( $T_j$ ), frequently limiting the switching frequency to 20 kHz or less. The much lower  $E_{off}$  allows SiC-MOSFETs to switch at much higher frequency, 50 kHz and higher. Size of passives and/or cooling systems thus can be significantly reduced.

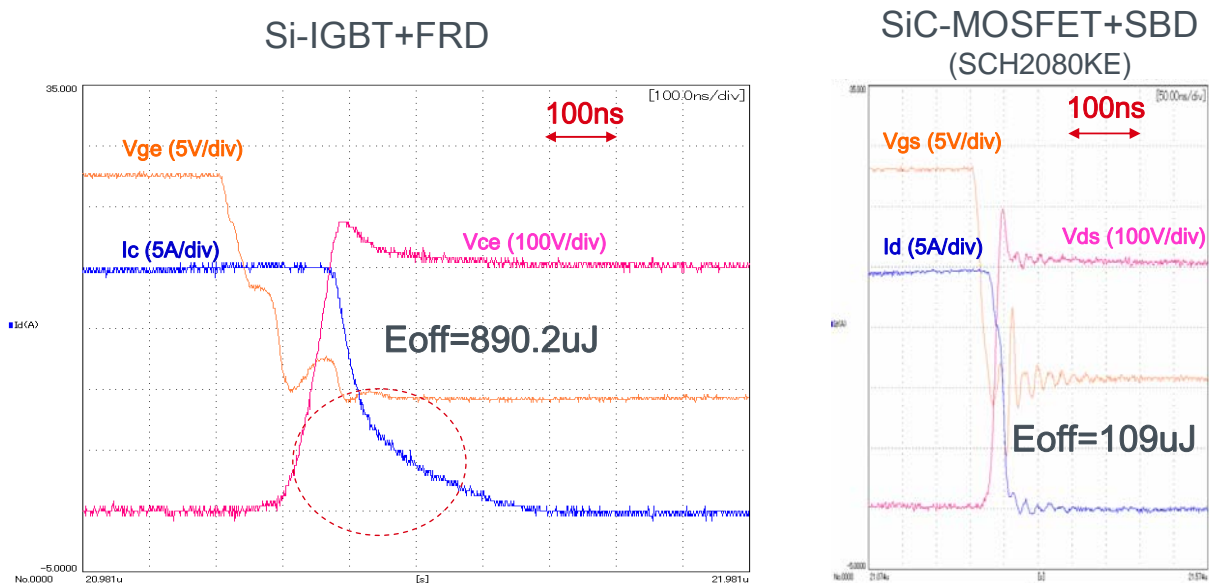
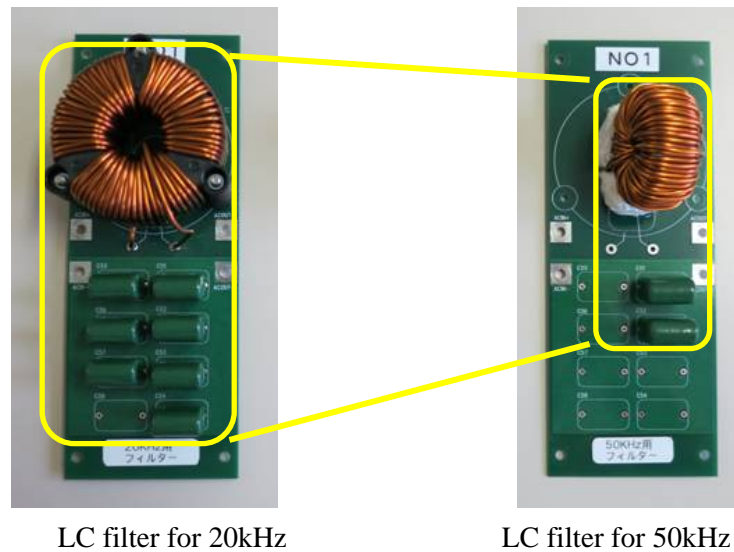


Figure 12

※These data are provided to show a result of evaluation done by ROHM for your reference. ROHM does not guarantee any of the characteristics shown here.

### Downsizing of Passive Components (LC filters) by Increase of Switching Frequency



**Figure 13**

#### 3.8 Internal gate resistance

The internal gate resistance is dependent on the sheet resistance of gate electrode material and chip size. Other things being equal, the internal gate resistance is inversely proportional to the chip size - the smaller the chip, the higher the gate resistance. At the same rating, SiC-MOSFET die is smaller than Si die. Therefore, SiC-MOSFETs tend to have lower junction capacitances but higher gate resistance. As an example, the internal gate resistance of Rohm's 1,200V/80mΩ SiC-MOSFET is approximately 6.3Ω.

Switching time is dependent largely on the external gate resistance. In order to implement fast switching operation, it is recommended to use low external gate resistor of several ohms while monitoring surge conditions.

### 3.9 Gate drive circuit

SiC-MOSFETs are normally OFF voltage-controlled devices. Hence they are easy to drive and incur less gate drive loss. The basic drive method is the same as that for IGBTs and Si-MOSFETs. The off-on gate voltage swing is nominally 0 to 18V. If high noise tolerance and fast switching are required, negative voltage of approximately -3 to -5V can also be used.

The following schematic shows connections to Rohm's gate driver IC BM6103FV-C with supply voltages of +18V and -4V. In order to drive a high-current element or a power module, it is recommended to use a buffer circuit. For fast switching, it is recommended to use low external gate resistor of several ohms.

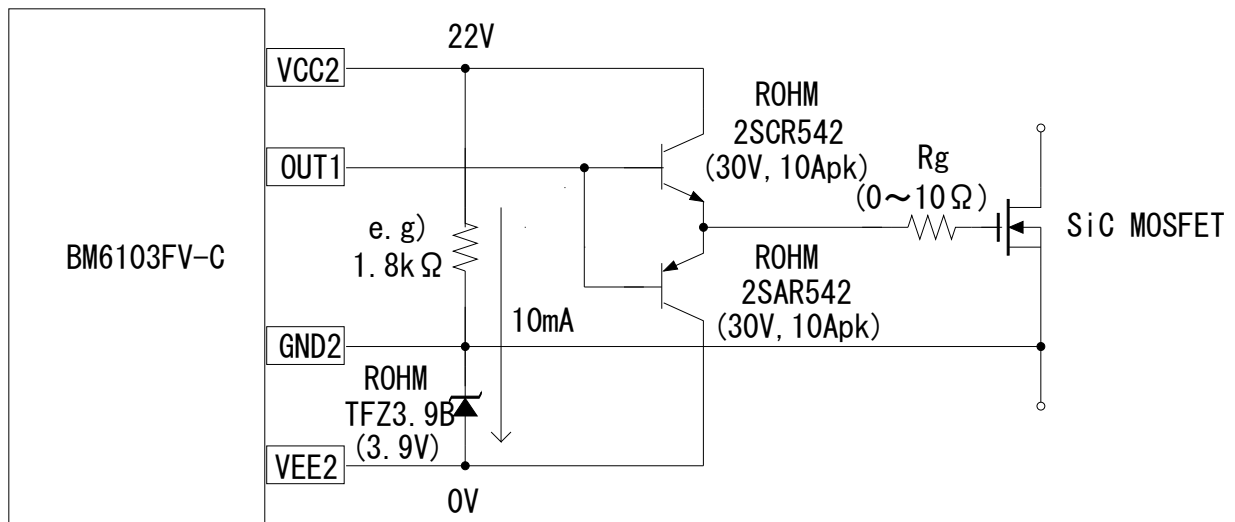


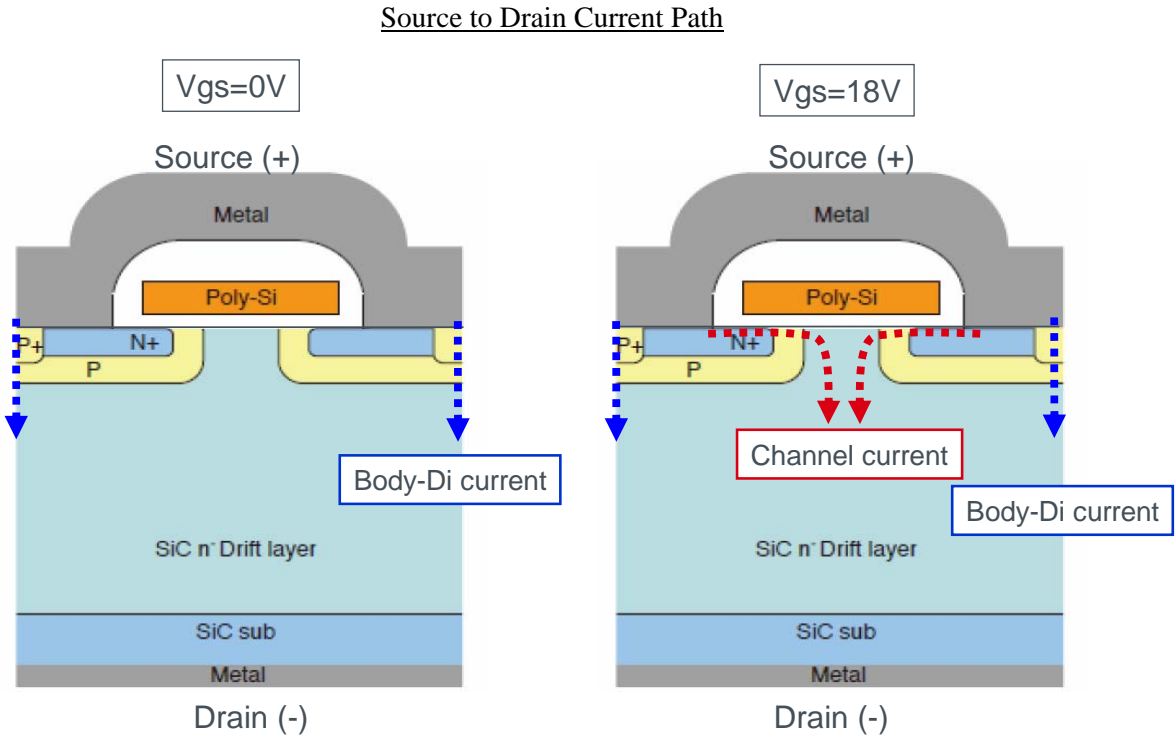
Figure 14

### 3.10 Forward characteristics of body diode and reverse conduction

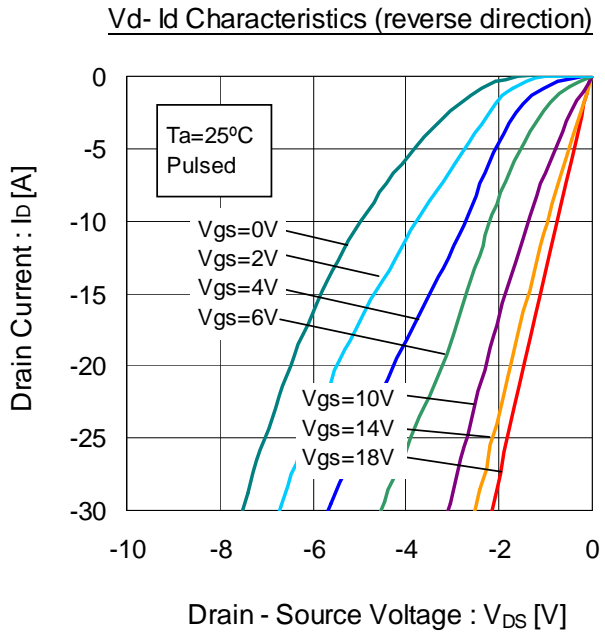
Like Si-MOSFET, SiC-MOSFET contains a parasitic (body) diode formed in the P-N junction. However, SiC MOSFET's body diode has high threshold voltage (around 3V) and relatively large forward voltage drop ( $V_f$ ) due to the fact that the bandgap of SiC is 3 times larger than that of Si. When connecting an external anti-parallel freewheeling diode to Si-MOSFET, an additional low-voltage blocking diode needed to be connected to MOSFET in series to prevent the conduction through the "slow" body diode. This is because  $V_f$  of the Si MOSFET's body diode is about the same as that of the external diode. This means more components and higher conduction loss. Such arrangement is not needed with SiC MOSFETs since the  $V_f$  of their body diodes is sufficiently high compared to that of a typical external free-wheeling diode.

The high  $V_f$  of the body diode can be reduced by turning on the gate voltage for reverse conducting like synchronous rectification. Since in inverter drives the gate of the switching devices is often turned on in the arm on the commutation side upon completion of dead time, commutation current is applied to the

body diode only during dead time. As a result, the high  $V_f$  of the body diode will not present problems even if a bridge circuit is composed only of SiC-MOSFETs (without anti-parallel connected SiC-SBDs). As described in Section 3.11, SiC MOSFETs' body diodes have extremely fast recovery characteristics.



**Figure 15**



**Figure 16**

### 3.11 Reverse recovery characteristics of body diode

The body diode of SiC-MOSFET is a P-N junction diode with short minority carrier lifetime. The recovery current is mainly to discharge junction capacitance. Its recovery performance is equivalent to that of a discrete SiC SBD. This enables a reduction in recovery loss to a fraction to a few to tens of percents compared to a body diode of Si-MOSFET or Si-FRD used with IGBT as a freewheeling diode.

Like SBD, the recovery time of the body diode is independent of forward current  $I_f$  and fixed for a given  $dI/dt$ . In inverter applications, SiC-MOSFET with or without anti-parallel SiC-SBD can achieve an exceptionally-low recovery loss and can be expected to reduce noises due to very small reverse recovery current.

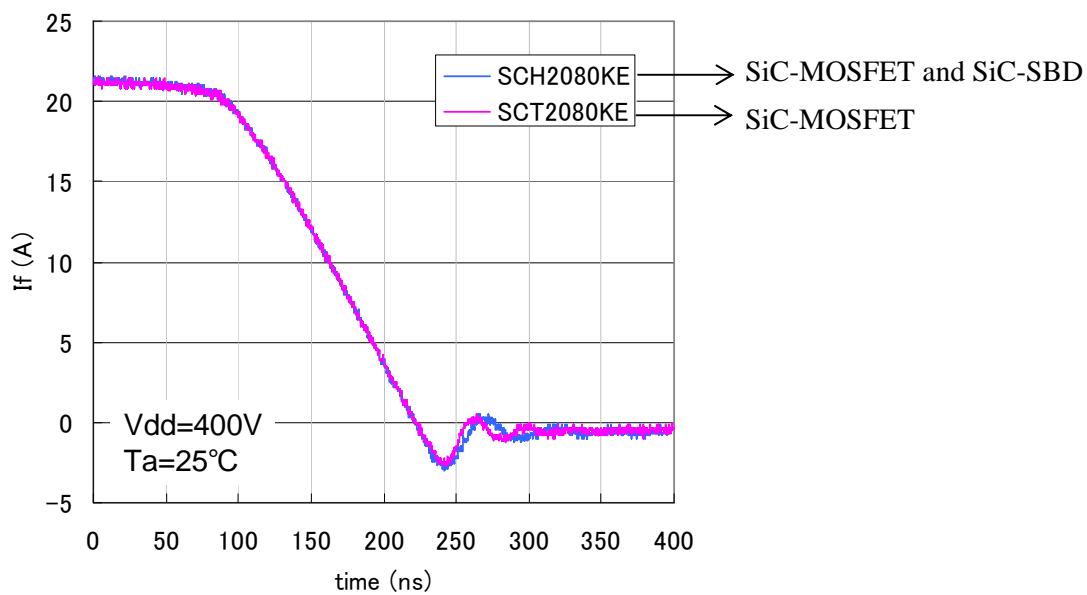


Figure 17

## 4. Characteristics of SiC power modules

### 4.1 Characteristics of SiC power module

Currently, IGBT modules that combine Si-IGBTs and Si-FRDs are commonly used as power modules to handle high currents and high blocking voltage. ROHM has pioneered commercial power modules equipped with SiC-MOSFETs and SiC-SBDs. SiC modules allow substantial reduction in switching losses associated with Si-IGBT's tail current and Si-FRD's recovery current. Among the benefits are:

- Improvement of conversion efficiency thanks to lower switching losses
- Simplification of thermal management, e.g., smaller and less expensive heat sink or cooling system, replacement of water/forced air with natural cooling
- Downsizing of passive components (inductors, capacitors) thanks to increasing switching frequency

SiC power modules are increasingly applied to power supplies for industrial equipments, PV power conditioners and others.

### 4.2 Topologies

Rohm's SiC power modules currently are available in half-bridge topologies and comprise either SiC-MOSFETs only or SiC MOSFETs with anti-parallel SiC SBDs.

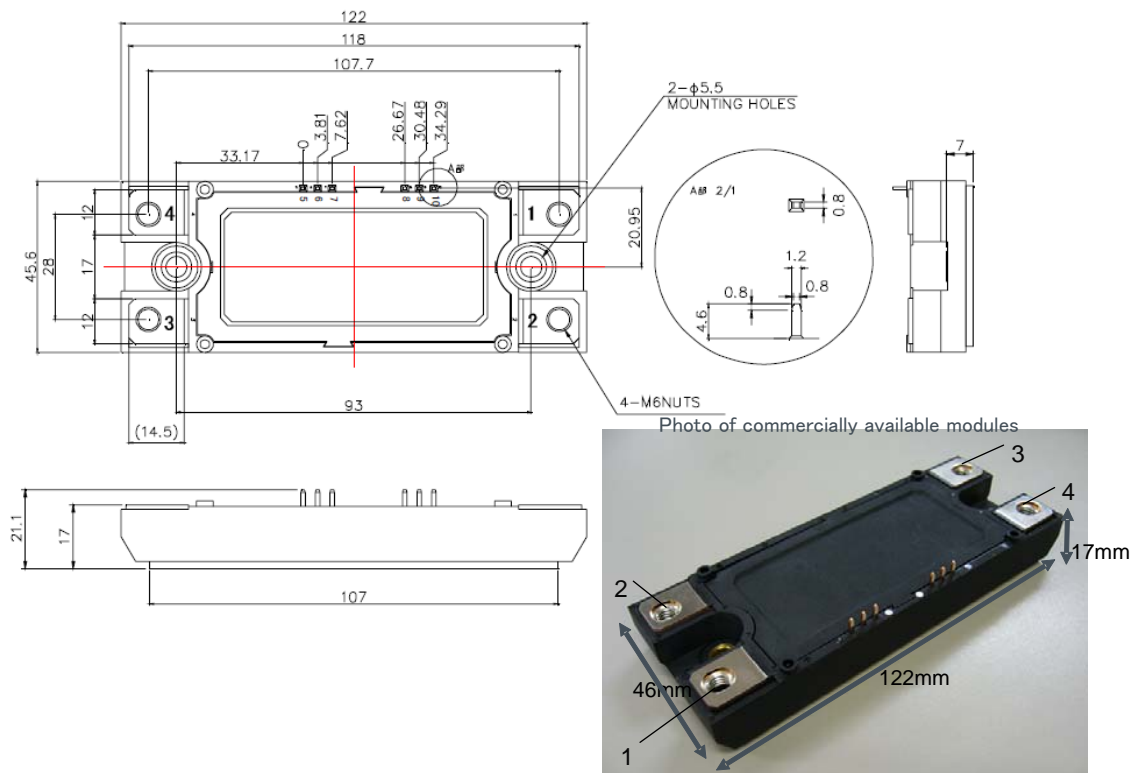
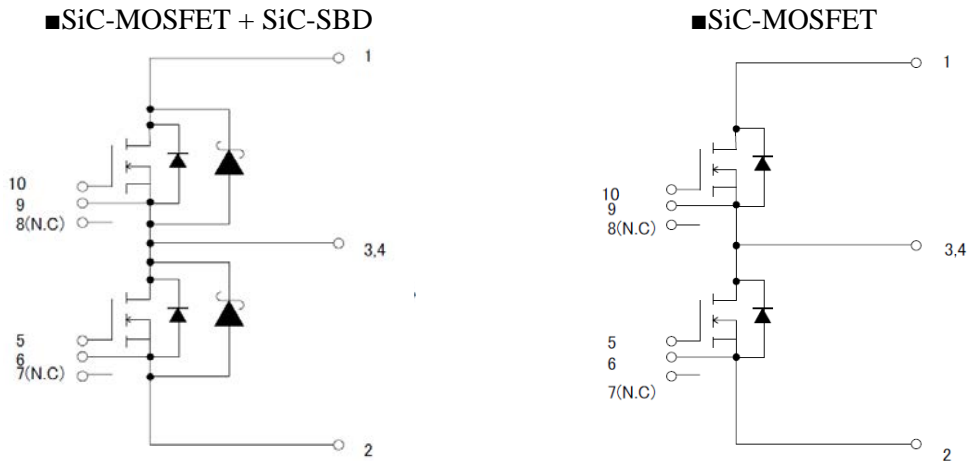


Figure 18

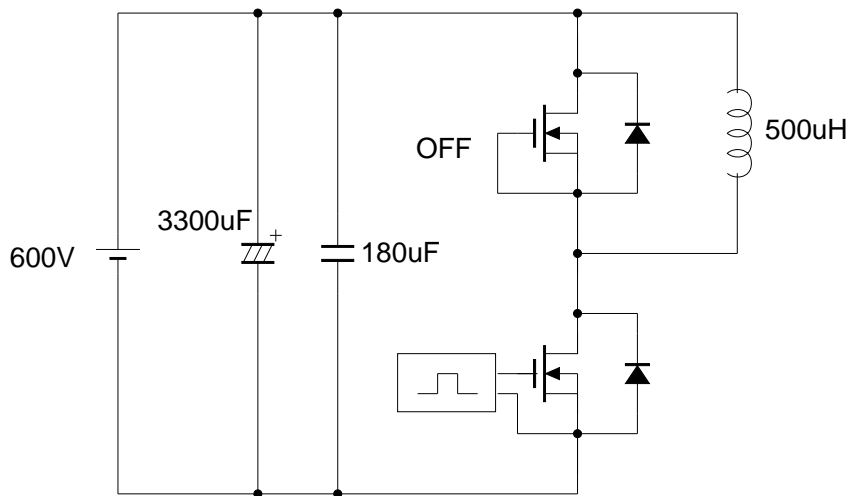
### Circuit Schematic of SiC Power Module (Half bridge Topology)



**Figure 19**

#### 4.3 Switching characteristics

The switching characteristics of SiC power module are evaluated using the double-pulse clamped inductive load test setup shown below. Parasitic inductance in the module is approximately 25nH, and that of the circuit is approximately 15nH.

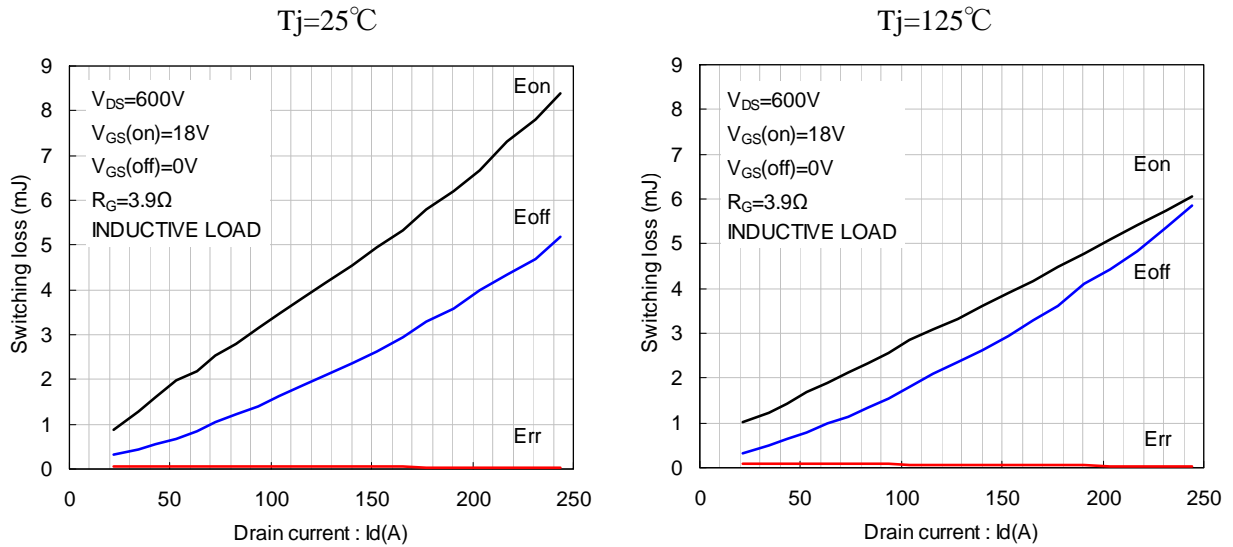


**Figure 20**

##### 4.3.1 $I_d$ and $T_j$ dependencies of switching characteristics

SiC power modules have almost zero recovery loss  $E_{rr}$  thanks to the fast recovery performance of SiC-SBDs (or body diodes of SiC-MOSFETs). Furthermore, they have exceptionally low  $E_{off}$  compared to IGBTs due to the absence of tail current in SiC-MOSFETs.  $E_{on}$  and  $E_{off}$  tend to increase in proportion to currents (the proportionality varies with external  $R_g$ ). Recovery current in Si-FRDs and tail current in IGBTs become higher at high temperatures, whereas SiC modules using majority carrier devices exhibit exceptionally small change in switching losses with increasing temperature. Also, the threshold voltage of SiC devices decrease at high temperatures. The net effect is that SiC power modules tends to have lower  $E_{on}$  and slightly higher  $E_{off}$  as operating temperature increases.

### Switching Loss vs. Drain Current

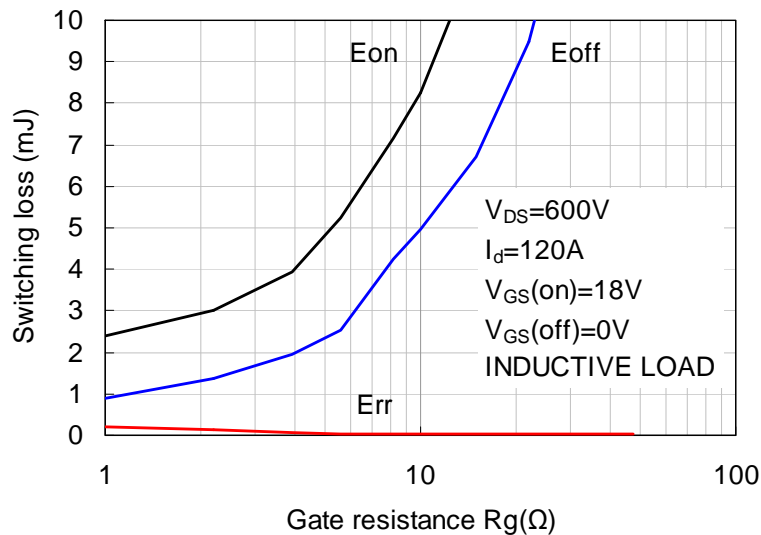


**Figure 21**

#### 4.3.2 Gate resistance dependency of switching characteristics

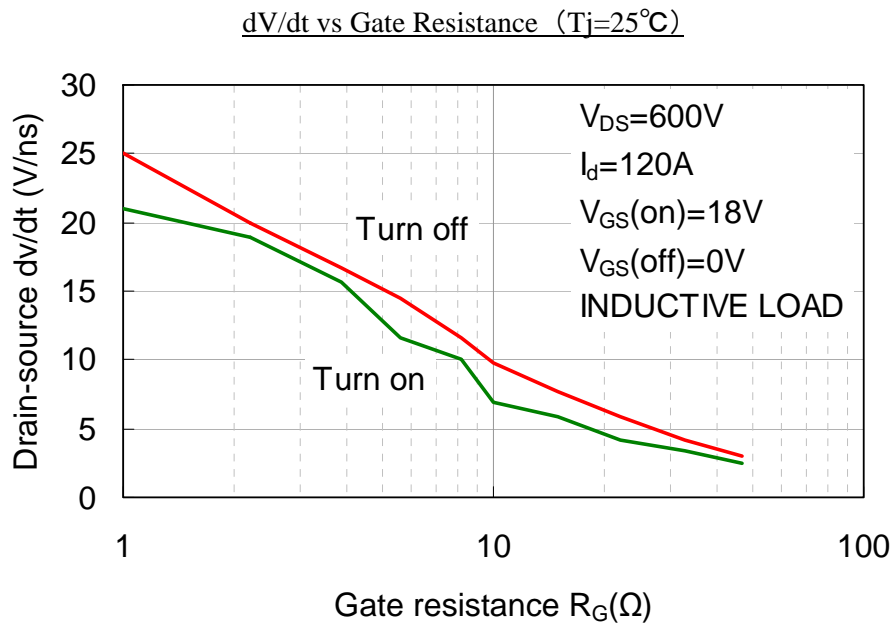
High external gate resistance reduces charge/discharge current to/from the gate and hence the switching rate. This may increase  $E_{on}$  and  $E_{off}$ , which results in inferior performance. To avoid that, select a low gate resistor wherever possible.

### Switching Loss vs. Gate Resistance ( $T_j=25^\circ\text{C}$ )

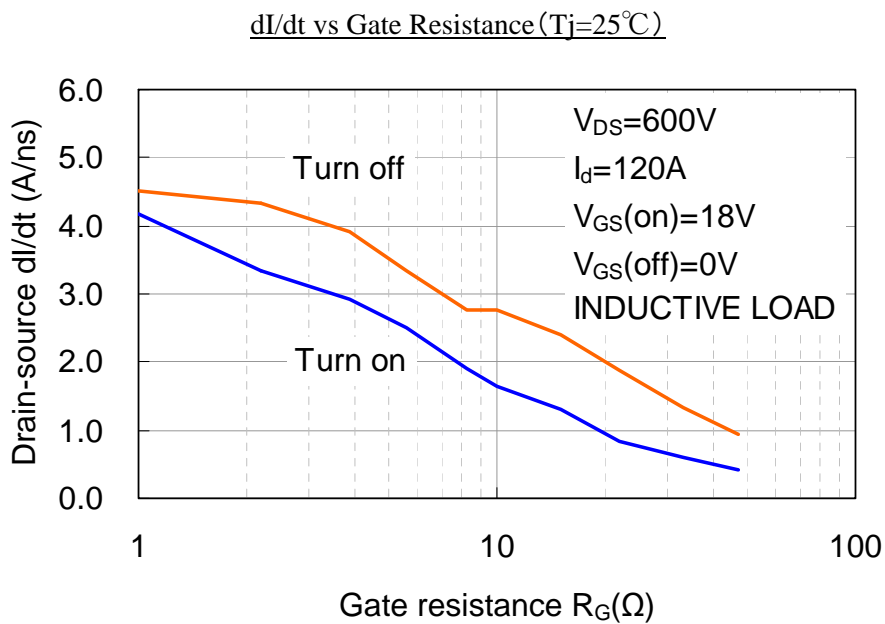


**Figure 22**

The following graphs show the dependency of  $dV/dt$  and  $dI/dt$  on the external gate resistance, respectively. ROHM has conducted tests on its SiC power modules under various operating conditions.  $dV/dt$  or  $dI/dt$  breakdown modes have never been observed in these tests.



**Figure 23**



**Figure 24**

#### 4.3.3 Gate voltage dependency of switching characteristics

The maximum V<sub>gs</sub> ratings of SiC-MOSFETs are -6V to +22V. The recommended gate drive voltages are V<sub>gs(on)</sub> = 18V and V<sub>gs(off)</sub> = 0V. If used, the recommended reverse bias voltage is from -3V to -5V. Within the specified ratings, the higher the magnitude of V<sub>gs(on)</sub> and V<sub>gs(off)</sub>, the faster the gate is charged/discharged, resulting in lower E<sub>on</sub> and E<sub>off</sub>.

#### 4.4 Comparison of switching loss with Si-IGBT power modules

The following section shows the results of comparisons of the latest 1,200V/100A half-bridge IGBT modules produced by three different companies (as of 2012) and Rohm's SiC module with same rating.

##### 4.4.1 Comparison of total switching loss with Si-IGBT power modules

If appropriate external gate resistance is selected, SiC power modules can reduce a total switching loss ( $E_{on} + E_{off} + E_{rr}$ ) by around 85% compared to state-of-the-art IGBT modules. This allows SiC power modules to be driven at a frequency of 50 kHz or higher and therefore to use of smaller passive filter components. Such operating conditions are difficult and generally not feasible with conventional IGBT modules. Furthermore, IGBT modules are normally used at about half the rated current due to the high switching loss which increases junction temperature. The current de-rating factor is much less with SiC modules because their switching loss is much lower. In other words, SiC modules can replace IGBT modules with higher rated current.

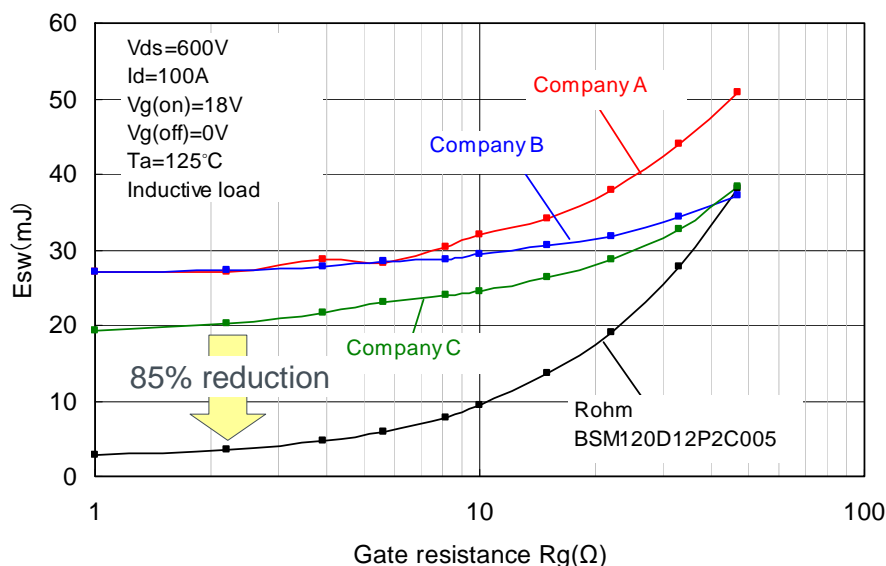


Figure 25

※These data are provided to show a result of evaluation done by ROHM for your reference. ROHM does not guarantee any of the characteristics shown here.

##### 4.4.2 Comparison of diode reverse recovery loss ( $E_{rr}$ ) with Si-IGBT power modules

IGBT modules incur large switching losses due to the high peak reverse recovery current of Si-FRDs. SiC-SBDs have exceptionally low  $I_{rr}$  and short  $t_{rr}$ . Consequently, SiC modules have negligibly small switching losses.

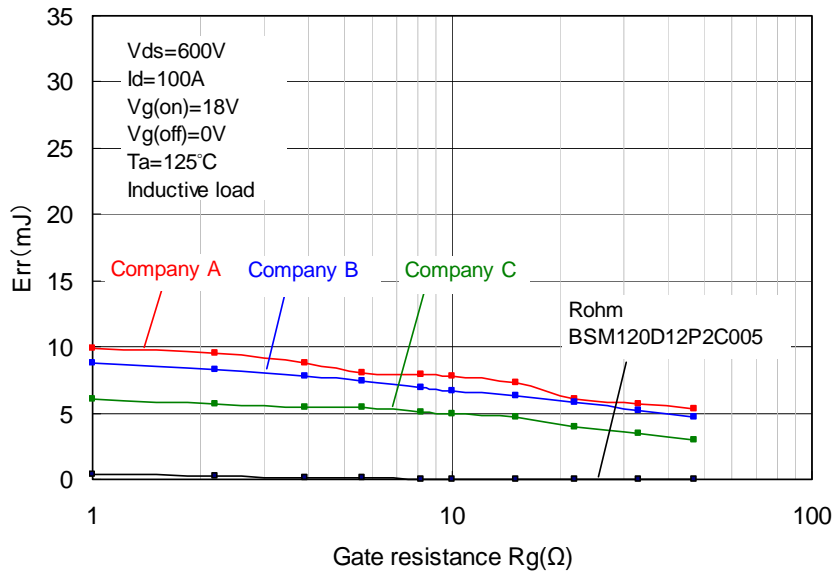


Figure 26

※These data are provided to show a result of evaluation done by ROHM for your reference. ROHM does not guarantee any of the characteristics shown here.

#### 4.4.3 Comparison of turn-on loss ( $E_{on}$ ) with Si-IGBT

Reverse recovery current generated by commutation current flows through the arm at the opposite side, resulting in an increase in the turn-on switching loss of the switching device. However,  $E_{on}$  loss in SiC modules is reduced thanks to its fast recovery performance. The lower the external gate resistance, the smaller the switching loss becomes.

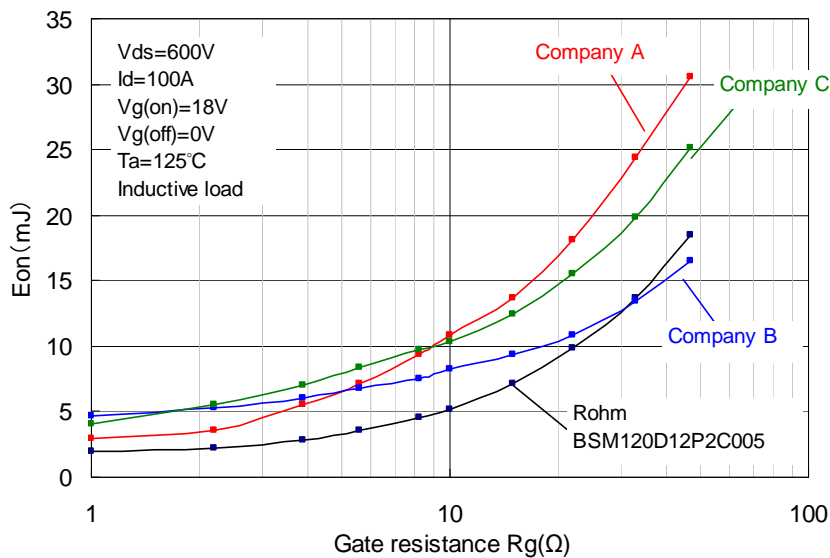


Figure 27

※These data are provided to show a result of evaluation done by ROHM for your reference. ROHM does not guarantee any of the characteristics shown here.

#### 4.4.4 Comparison of turn-off loss (E<sub>off</sub>) with Si-IGBT power modules

The turn-off loss of IGBTs is due to their tail current. Their E<sub>off</sub> is high and is largely not dependent on gate resistance. In contrast, SiC-MOSFETs have no tail current, allowing low-loss, ultrahigh-speed switching. The lower the external gate resistance, the lower the switching loss becomes.

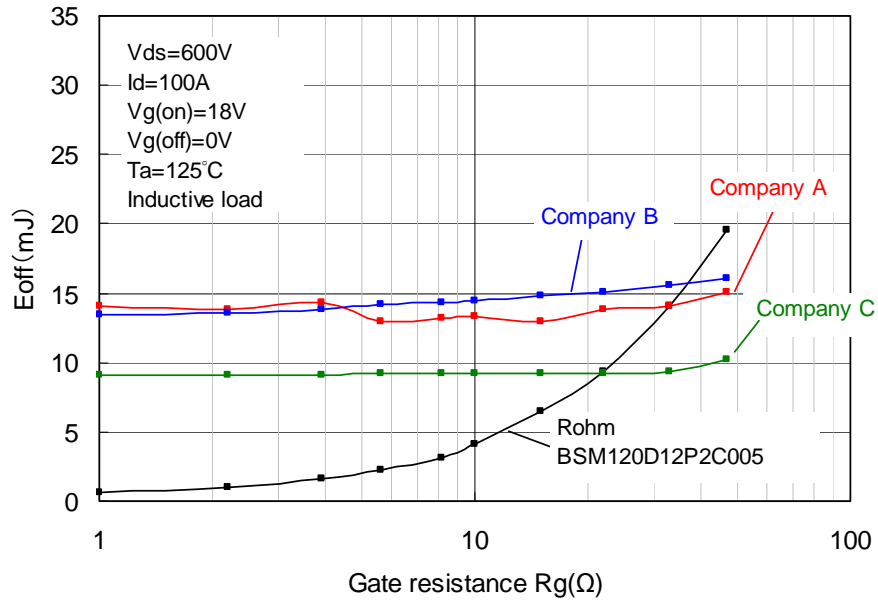


Figure 28

※These data are provided to show a result of evaluation done by ROHM for your reference. ROHM does not guarantee any of the characteristics shown here.

## 5. Reliability of SiC-SBD

### 5.1 dV/dt and dI/dt break-down

Breakdown in the outer periphery structure of SiC-SBD caused by high dV/dt were reported for conventional products from other suppliers. Such breakdowns have not been observed in ROHM's SiC SBDs at dV/dt up to 50 kV/us.

Furthermore, Si-FRDs exhibit breakdown due to the very large reverse recovery current induced by high dI/dt. This is extremely unlikely with SiC-SBDs since they have much lower recovery current.

### 5.2 Results of SiC-SBD reliability tests

寿命試験 (Life Test)				
試験項目 Test Item	試験方法/準拠規格 Test Method/Standard	試験時間 Test Condition	サンプル数 n(pcs)	不良数 pn
高温逆バイアス試験 High Temperature reverse bias	Ta=Tjmax, VR=Vrmax X 0.8 EIAJ ED-4701/100-101	1000h	22	0
高温高湿バイアス Temperature humidity bias	Ta=85°C, Rh=85%, VR=100V EIAJ ED-4701/100-102	1000h	22	0
温度サイクル Temperature cycle	Ta= -55°C (30min) ~ Ta=150°C (30min) EIAJ ED-4701/100-105	100cycle	22	0
蒸気加圧 Pressure cooker	Ta=121°C, 2atm, Rh=100% JESD22-A102C	48h	22	0
高温保存 High Temperature storage	Ta= 175°C EIAJ ED-4701/100-201	1000h	22	0
低温保存 Low Temperature storage	Ta= -55°C EIAJ ED-4701/100-202	1000h	22	0

強度試験 (Stress Test)				
試験項目 Test Item	試験方法/準拠規格 Test Method/Standard	試験時間 Test Condition	サンプル数 n(pcs)	不良数 pn
はんだ耐熱性1 Resistance to solder heat1	260±5°Cのはんだ槽に端子を浸漬 Dipping leads into solder bath at 260±5°C. EIAJ ED-4701/300-302	10sec	22	0
はんだ耐熱性2 Resistance to solder heat2	350±10°Cのはんだ槽に端子を浸漬 Dipping leads into solder bath at 350±10°C. EIAJ ED-4701/300-302	3.5sec	22	0
はんだ付け性 Solderability	235±5°Cのはんだ槽に端子を浸漬 Dipping leads into solder bath at 235±5°C. EIAJ ED-4701/300-303	5sec	22	0
熱衝撃 Thermal shock	0 +5 (5min) ~ 100 +0 (5min) EIAJ ED-4701/300-307	100cycle	22	0
端子強度 (引張り) Terminal strength (Pull)	引張力 ; 20N Pull force ; 20N EIAJ ED-4701/400-401	10sec	22	0
端子強度 (曲げ) Terminal strength (Bending)	曲げ荷重 ; 10N Bending load ; 10N EIAJ ED-4701/400-401	2times	22	0

※ 故障判定は仕様書に記載されている電気的特性にて行っています。

Failure criteria : According to the electrical characteristics specified by the specification.

はんだ付け性試験については濡れ面積≧95%にて判定しています。

Regarding solderability test, failure criteria is 95% or more area covered with solder.

※ サンプル基準: 信頼度水準90%, 不合格信頼性水準  $\lambda=10\%$ , C=0判定を採用し, MIL-STD-19500の指数分布型計数1回抜取表に従い, サンプルを22個としています。

Sample standard: [Reliability level:90%][Failure reliability level( $\lambda$ ):10%][C=0 decision] is adopted. And the number of samples is being made 22 in accordance with single sampling inspection plan with exponential distribution type based on MIL-STD-19500.

Table 2

# 6. Reliability of SiC-MOSFET

## 6.1 Reliability of gate insulating layer

Oxide is used as gate insulating layer. Its reliability directly affects SiC MOSFETs' reliability. Development of high-quality oxide has been a challenging problem for the industry. ROHM solved this issue by a combination of appropriate oxide growth process and device structures. As the CCS-TDDB (Constant Current Stress Time Dependent Dielectric Breakdown) data show, its SiC MOSFETs have achieved quality equivalent to that of Si-MOSFETs and IGBTs.

Referring to Figure 29,  $Q_{BD}$  serves as quality indicator of the gate oxide layer. The value of 15 - 20C/cm<sup>2</sup> is equivalent to that of Si-MOSFETs.

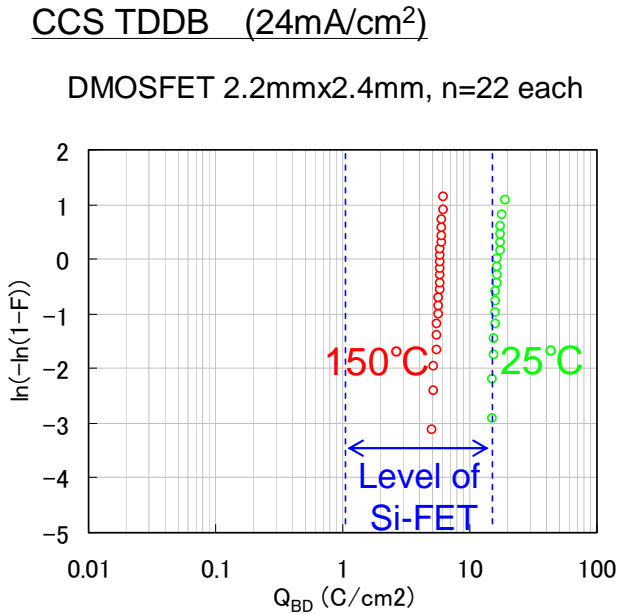


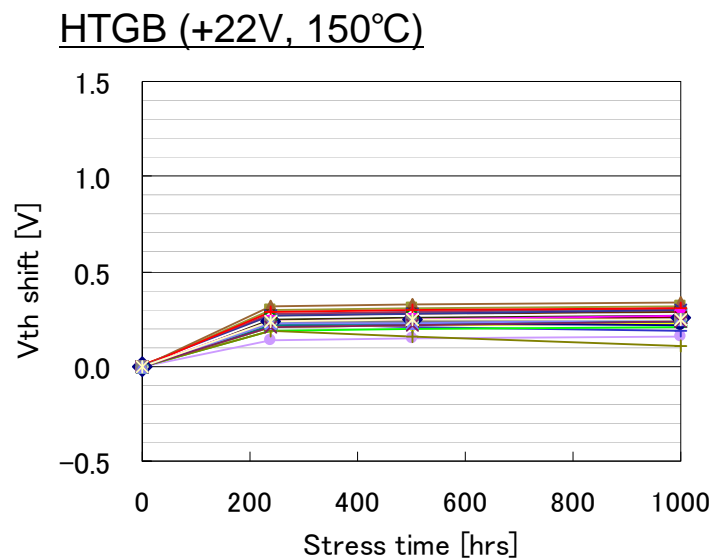
Figure 29

Even with high quality gate insulating layer, there still remains crystal defects that may cause initial failures. ROHM uses its unique screening technologies to identify and eliminate defective devices from the production chain.

As the result of HTGB (High Temperature Gate Bias) tests conducted at +22V and 150°C, ROHM has confirmed 1,000 operating hours without any failures and characteristic fluctuations in 1,000 devices and a lapse of 3,000 hours in 300 devices.

## 6.2 Stability of gate threshold voltage against positive gate voltage

As the current technology level, electron traps are formed at the interface between gate insulating layer and SiC body. Electrons can be trapped and consequently increase the threshold voltage if a continuous positive gate voltage is applied for an extended period of time. However, the shift in threshold voltage is very small, 0.2 - 0.3V, after 1000 operating hours at 150°C and  $V_{gs} = +22V$ . This shift is the smallest in the industry. Since most of the traps are all filled in the first several tens of hours, the threshold is fixed and remains stable after that.

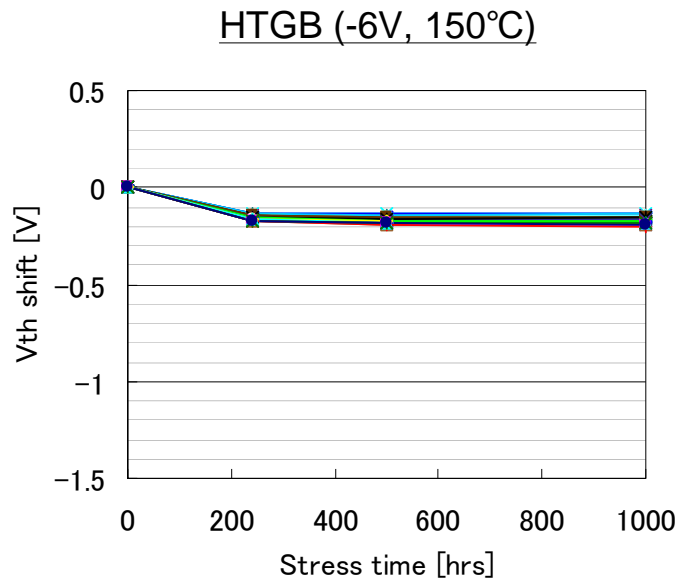


**Figure 30**

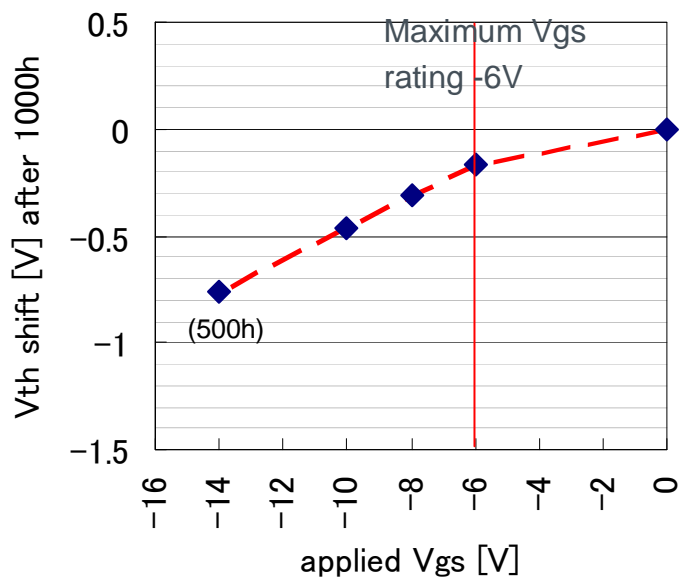
## 6.3 Stability of gate threshold voltage against negative gate voltage

The threshold drops due to trapped holes when continuous negative voltage is applied to the gate for an extended period of time. This threshold shift is larger than that caused by positive gate voltage, e.g., the threshold drops by 0.5V or more when  $V_{gs}$  is set to  $-10V$  or more. With Rohm's second-generation MOSFETs (SCT2xxx series and SCH2xxx series), the shift does not exceed 0.3V, provided that the gate is not reverse biased beyond  $-6V$ . Negative gate voltage lower than  $-6V$  causes a significant drop in the threshold.

In normal operation, gate voltage alternates between positive and negative biases and thus repeatedly charges and discharges the traps making unlikely to have significant changes in the threshold.



**Figure 31**



**Figure 32**

#### 6.4 Reliability of body diodes

Another mechanism that affects SiC MOSFET's reliability is the degradation caused by its body diode's conduction. If forward current is continually applied to SiC P-N junction such as body diodes in MOSFETs, a plane defect called stacking fault will be extended due to the hole-electron recombination energy. Such faults block the current pathway, thus increasing on-resistance and  $V_f$  of the diode. Increasing the on-resistance by several times disrupts the thermal design. Furthermore stacking faults may degrade the blocking voltage. For this reason, using SiC MOSFETs whose body diodes degrade with

conduction in circuit topologies that causes commutation to the body diode, e.g. bridge topologies in inverters, might result in serious problems. This reliability problem only occurs with bipolar devices, not with SiC-SBDs and the first-quadrant operation of SiC-MOSFETs.

ROHM has reduced crystal defects in SiC wafers and epitaxial layers and developed the proprietary process that prevents propagation of stacking faults, ensuring the reliability of body diode conduction. This is confirmed in 8A DC, 1,000-hour conduction tests which shows no degradation in all characteristics, including on-resistance and leakage current. This ensures worry-free use of SiC-MOSFETs in circuits that cause commutation to the body diodes.

Furthermore, reverse conduction reliability tests with  $V_{gs} = 18V$  and  $I_d = 15A$  DC (also 1,000-hour) also shows no significant changes in electrical characteristics.

Body-diode conduction test ( $I_f=8A$  DC,  $T_a=25^\circ C$ , 1000h)  
 DUT: SCT2080KE (TO247 w/o SiC SBD),

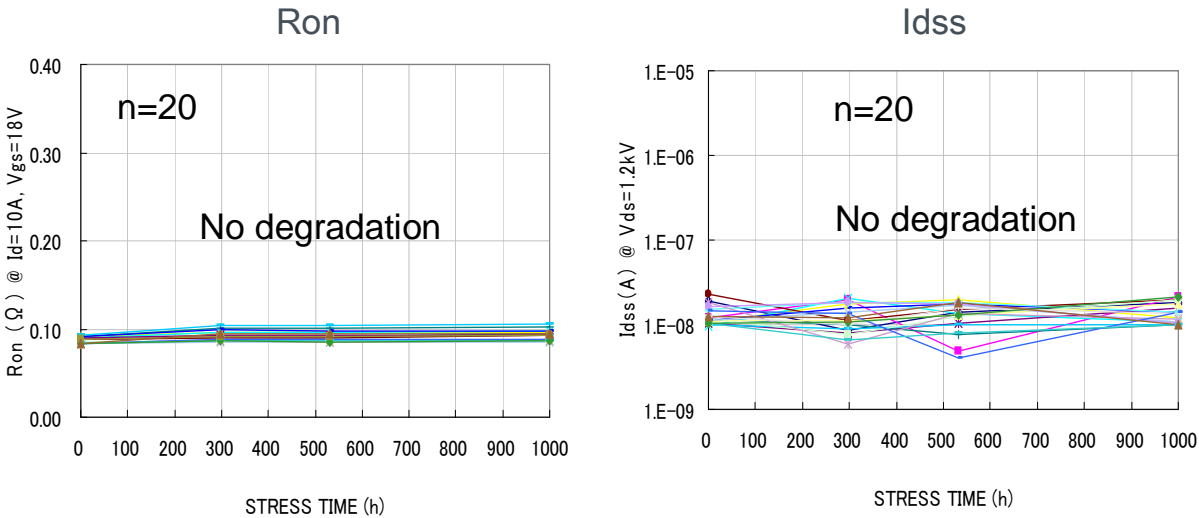


Figure 33

6.5 Short circuit safe operation area

Since SiC-MOSFETs have smaller chip area and higher current density than Si devices, they tend to have lower short circuit withstand capability (thermal fracture mode) compared to the Si devices. 1,200V SiC-MOSFETs in TO247 package have short circuit withstand time (SCWT) of approximately 8 to 10 μs when Vdd is set to 700V and Vgs is set to 18V. SCWT is longer with lower gate voltage, which reduces saturation current and lower power supply voltage, which generate less heat.

Many gate driver ICs incorporate functions that simplify detection and management of short circuit condition. For example, Rohm’s BM6103FV-C can shutdown the switch in approximately 2 μs once over current is detected. It has soft turn-off capability to gradually reduce the gate voltage during turnoff to

prevent high surge voltage, which is induced by high  $dI/dt$  across the drain and source inductance. It is advised to pay careful attention not to apply over voltage by using such a soft turn on function or other preventative measures.

## 6.6 $dV/dt$ breakdown

Si-MOSFETs involve a breakdown mode in which high  $dV/dt$  causes transient current to pass through the capacitance  $C_{ds}$  and turn on the parasitic bipolar transistor, leading to device breakdown. This is less likely an issue with SiC-MOSFETs since the current gain of their parasitic bipolar transistors are low. So far such breakdown mode has never been observed with ROHM's SiC-MOSFETs operating with  $dV/dt$  at up to 50 kV/ $\mu$ s.

Since SiC-MOSFETs generate exceptionally low recovery current, reverse recovery current also will not cause high  $dV/dt$ . Consequently, SiC-MOSFETs are considered unlikely to cause this breakdown mode.

## 6.7 Neutron-induced single event burnout

In high-altitude applications, random failures such as SEB (single event burnout) of semiconductor devices caused by neutrons or heavy ions become an issue. Irradiation tests of white neutron beam (energy: 1 to 400MeV) on Rohm's 1,200V SiC-MOSFETs were conducted at the Research Center for Nuclear Physics, Osaka University (RCNP). On the 5 test samples, there were no failures due to single event phenomenon with an irradiation fluence of  $1.87 \times 10^9$  [neutron/cm<sup>2</sup>] with  $V_{ds}$  set to 840V (equivalent to 70% of the rated breakdown voltage). The failure rate is calculated to be less than 1.37FIT at 0 m above sea level and less than 35.3FIT at 4,000 m above sea level ( "less than" because there's no failure). This indicates that SiC-MOSFETs present no problems in high-altitude applications. Since SiC-MOSFETs are relatively small in chip size compared to Si devices and ROHM's SiC MOSFETs have adequate breakdown voltage margin, they can have a low failure rate from cosmic ray radiation.

## 6.8 Electrostatic discharge withstand capability

The smaller chip size of SiC MOSFETs means lower electrostatic discharge (ESD) withstand capability relative to silicon devices. Therefore it's advised to handle SiC devices with adequate ESD protection measures.

### Examples of ESD protection measures

- Eliminate static electricity from human body, devices, and work environment using ionizers.
- Eliminate static electricity from human body and work environment using wristbands and grounding.  
This measure is ineffective against charged devices.

## 6.9 Results of SiC-MOSFET reliability tests

寿命試験 (Life Test)				
試験項目 Test Item	試験方法／準拠規格 Test Method/Standard	試験時間 Test Condition	サンプル数 n(pcs)	不良数 pn
高温逆バイアス試験 High Temperature Reverse Bias	Ta=Tjmax、V <sub>DS</sub> =V <sub>rmax</sub> X 0.8 EIAJ ED-4701/100-101	1000h	22	0
高温ゲートバイアス試験 High Temperature Gate Bias	Ta=Tjmax、V <sub>GS</sub> =+22V EIAJ ED-4701/100-101	1000h	22	0
高温ゲートバイアス試験 High Temperature Gate Bias	Ta=Tjmax、V <sub>GS</sub> = -6V EIAJ ED-4701/100-101	1000h	22	0
高温高湿バイアス Temperature humidity bias	Ta=85°C、Rh=85%、V <sub>DS</sub> =100V EIAJ ED-4701/100-102	1000h	22	0
温度サイクル Temperature cycle	Ta= -55°C (30min) ~ Ta=150°C (30min) EIAJ ED-4701/100-105	100cycle	22	0
蒸気加圧 Pressure cooker	Ta=121°C、2atm、Rh=100% JESD22-A102C	48h	22	0
高温保存 High Temperature storage	Ta= 150°C EIAJ ED-4701/100-201	1000h	22	0
低温保存 Low Temperature storage	Ta= -55°C EIAJ ED-4701/100-202	1000h	22	0

強度試験 (Stress Test)				
試験項目 Test Item	試験方法／準拠規格 Test Method/Standard	試験時間 Test Condition	サンプル数 n(pcs)	不良数 pn
はんだ耐熱性1 Resistance to solder heat1	260±5°Cのはんだ槽に端子を浸漬 Dipping leads into solder bath at 260±5°C. EIAJ ED-4701/300-302	10sec	22	0
はんだ耐熱性2 Resistance to solder heat2	350±10°Cのはんだ槽に端子を浸漬 Dipping leads into solder bath at 350±10°C. EIAJ ED-4701/300-302	3.5sec	22	0
はんだ付け性 Solderability	235±5°Cのはんだ槽に浸漬 Dipping into solder bath at 235±5°C. EIAJ ED-4701/300-303	5sec	22	0
熱衝撃 Thermal shock	0 <sup>+5</sup> <sub>-0</sub> (5min) ~ 100 <sup>+0</sup> <sub>-5</sub> (5min) EIAJ ED-4701/300-307	100cycle	22	0
端子強度 (引張り) Terminal strength (Pull)	引張力 ; 20N Pull force ; 20N EIAJ ED-4701/400-401	10sec	22	0
端子強度 (曲げ) Terminal strength (Bending)	曲げ荷重 ; 10N Bending load ; 10N EIAJ ED-4701/400-401	2times	22	0

※ 故障判定は仕様書に記載されている電気的特性にて行っています。

Failure criteria : According to the electrical characteristics specified by the specification.

はんだ付け性試験については濡れ面積≥95%にて判定しています。

Regarding solderability test, failure criteria is 95% or more area covered with solder.

※ サンプル基準:信頼度水準90%,不合格信頼性水準λ1=10%,C=0判定を採用し,MIL-STD-19500の指数分布型計数1回抜取表に従いサンプルを22個としています。

Sample standard:[Reliability level:90%][Failure reliability level(λ1):10%][C=0 decision] is adopted. And the number of samples is being made 22 in accordance with single sampling inspection plan with exponential distribution type based on MIL-STD-19500.

Table 3

## 7. Instructions to use SiC power modules and their reliability

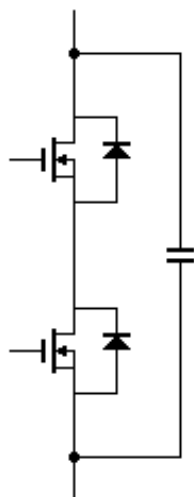
### 7.1 Measures to reduce surge voltage

Since SiC modules support high switching speed and handles high currents, surge voltage ( $V = -L \times dI/dt$ ) is generated due to wire inductance  $L$  in the module or at its periphery and may exceed the rated voltage. Below is a list of recommendations to prevent or mitigate this problem. However, these measures may have an impact on the switching performance.

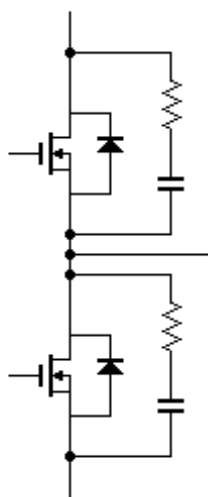
- Reduce wire inductance by using thick and short wirings in both main and snubber circuits.
- Place capacitors close to MOSFETs to reduce wire inductance.
- Add snubber circuit
- Increase gate resistance to reduce  $dI/dt$

#### Examples of snubber circuits

<C snubber circuit>



<RC snubber circuit>



<RCD snubber circuit>

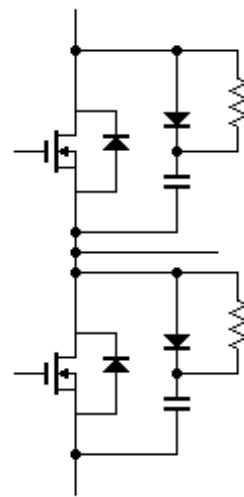


Figure 34

### 7.2 Bridge arm short circuit by self turn-on

Referring to Figure 35 below, when the MOSFET M1 of the upper arm of a half bridge turns on, reverse recovery current flows through the freewheeling diode (external SiC-SBD or body diode) of the MOSFET M2 of the lower arm and raises the drain-source voltage of M2. Due to this  $dV/dt$ , transient gate current ( $I = Cr_{ss} \times dV/dt$ ) through the reverse transfer capacitance  $Cr_{ss}$  of M2 flows into the gate resistance, thus resulting in a rise in the gate voltage of M2. If this voltage rise exceeds the gate threshold voltage of M2, short-circuit current flows through both the upper and the lower arms.

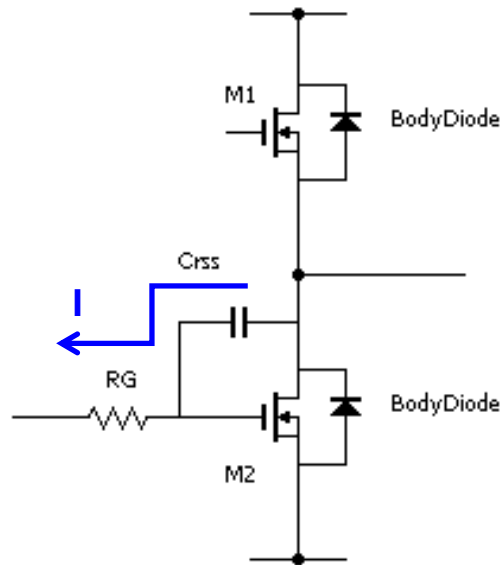


Figure 35

While the threshold voltage of SiC-MOSFET defined at several milli-amperes is as low as around 3V, the gate voltage required to conduct high current is 8V or higher. As a result, withstand capability of bridge arm short circuit is not significantly different from that of IGBTs. However, to prevent this unexpected short circuit, it is recommended to take measures listed below which are also valid for Si power modules. However, these measures may influence the switching performance. Adjustment of the circuit with monitoring waveforms to prevent self turn-off is advised.

- Increase negative gate bias voltage to turn OFF the MOSFET.
- Add a capacitor between the gate and the source.
- Add a transistor between the gate and the source that clamps  $V_{gs}$  to ground when the switch is off
- Increase the gate resistance to reduce the switching rate.

### 7.3 RBSOA (Reverse bias safe operating area)

Like IGBT modules, the RBSOA (Reverse Bias Safe Operating Area) of SiC power modules covers the entire range of twice the rated current  $\times$  Rated voltage.

## 7.4 Results of SiC power module reliability tests

寿命試験 (Life Test)				
試験項目 Test Item	試験方法/準拠規格 Test Method/Standard	試験時間 Test Condition	サンプル数 n(pcs)	不良数 pn
ΔTjパワーサイクル ΔTj power cycle	ΔTj=100°C±5°C、Tj≤150°C、Ta=25±5°C EIAJ ED-4701/100-106	15000cyc	5	0
ΔTcパワーサイクル ΔTc power cycle	ΔTc=50°C±5°C、Tj≤150°C、Ta=25±5°C EIAJ ED-4701/100-106	5000cyc	5	0
温度サイクル Temperature cycle	-40°C(60min)~RT(30min)~ 125°C(60min)~RT(30min) EIAJ ED-4701/100-105	100cyc	5	0
耐湿試験 Temperature humidity storage	85°C/85% EIAJ ED-4701/100-103	1000h	5	0
高温保存 High Temperature storage	Ta=150°C EIAJ ED-4701/100-201	1000h	5	0
低温保存 Low Temperature storage	Ta=-40°C EIAJ ED-4701/100-202	1000h	5	0
高温ゲートバイアス(+) High temperature gate bias(+)	Vgs=22V、Ta=150°C JESD22-A108	1000h	5	0
高温ゲートバイアス(-) High temperature gate bias(-)	Vgs=-6V、Ta=150°C JESD22-A108	1000h	5	0
高温逆バイアス High temperature reverse bias	Vds=960V、Vgs=0V、Ta=150°C EIAJ ED-4701/100	1000h	5	0
強度試験 (Stress Test)				
試験項目 Test Item	試験方法/準拠規格 Test Method/Standard	試験時間 Test Condition	サンプル数 n(pcs)	不良数 pn
振動 Vibration	10~500Hz/15min 100m/s <sup>2</sup> Each X,Y,Z axis, EIAJ ED-4701/400-403 condition code B	6h (2h / direction)	5	0
衝撃 Shock	5000m/s <sup>2</sup> pulse width 1msec Each X,Y,Z axis, EIAJ ED-4701/400-404 condition code B	3times / direction	5	0
熱衝撃 Thermal shock	0 + <sub>0</sub> <sup>5</sup> (5min) ~ 100 + <sub>-5</sub> <sup>0</sup> (5min) EIAJ ED-4701/300-307 condition code A	10cyc	5	0
端子強度 (引張り) Terminal strength (Pull)	Pull force : 40N(main terminal), 20N(signal terminal) EIAJ ED-4701/401- I	10sec	5	0
締め付けトルク強度 Mounting strength	3.5N・m(M5) EIAJ ED-4701/402- II	10sec	5	0

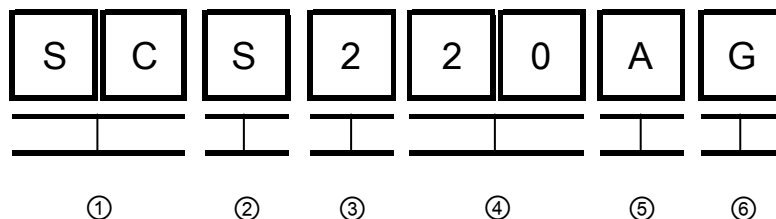
※ 故障判定項目は仕様書に記載されている電気的特性にて行っています。

Failure criteria : According to the electrical characteristics specified by the specification.

Figure 36

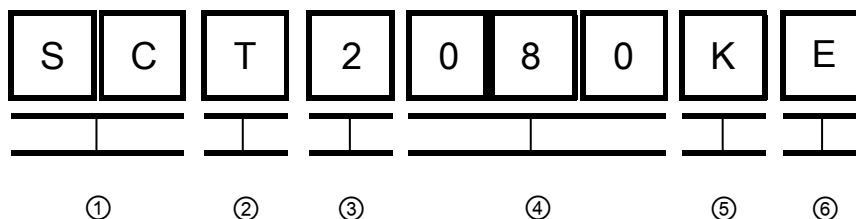
## 8. Definition of part number

### 8.1 SiC-SBD (discrete components)



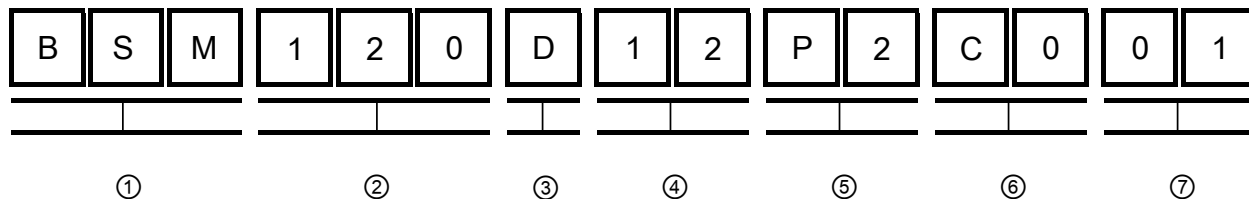
- ① Code stands for SiC
- ② Code stands for SBD
- ③ Generation of the device
- ④ Rating Current [in A]      0 5 → 5A  
2 0 → 20A
- ⑤ Voltage                      A: 600V, 650V  
K: 1200V
- ⑥ Package                      E2: TO247 [3pin, 2dice]  
G: TO220AC [2pin]  
J: LPTL [D2PAK]  
M: TO220FM [2pin]

### 8.2 SiC-MOSFET (discrete components)



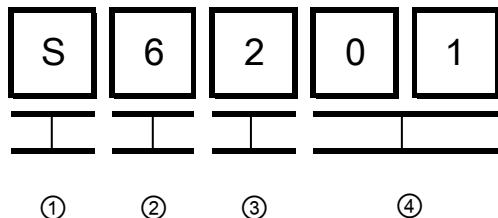
- ① Code stands for SiC
- ② Code stands for product type    T: MOSFET  
H: MOSFET+SBD
- ③ Generation of the device
- ④  $R_{dson}$  [in  $m\Omega$ ]              0 8 0: typ. 80 $m\Omega$   
1 6 0: typ. 160 $m\Omega$
- ⑤ Voltage                      A: 600V, 650V  
K: 1200V
- ⑥ Package                      E: TO247  
F: TO220AB

### 8.3 SiC Power Modules



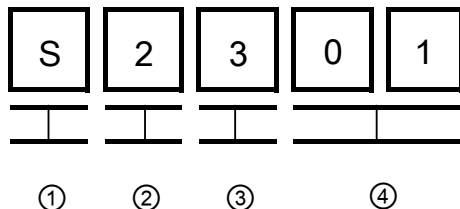
- ① Code stands for SiC power module
- ② Rating current [in A]                    1 2 0: 120A
- ③ Half bridge
- ④ Voltage                                        1 2: 1200V  
    1 7: 1700V
- ⑤ Type and generation of the device
- ⑥ Module case
- ⑦ Added number

### 8.4 SiC-SBD (bare dice)



- ① Code stands for SiC
- ② Code stands for SBD
- ③ Generation and voltage
  - 0: 1G 600V
  - 1: 1G 1200V
  - 2: 2G 600V/650V
  - 3: 2G 1200V
  - 4: 2G 1700V
- ④ Added number

### 8.5 SiC-MOSFET (bare dice)

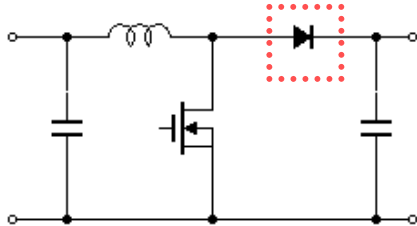


- ① Code stands for SiC
- ② Code stands for MOSFET
- ③ Generation and voltage
  - 2: 2G 650V
  - 3: 2G 1200V
  - 4: 2G 1700V
- ④ Added number

## 9. Examples of applications and benefits of using SiC

### 9.1 Power factor correction (PFC) circuits (CCM - Continuous conduction mode)

- Improvement of conversion efficiency and noise reduction due to elimination of reverse recovery current
  - Downsizing of passive filter components under high frequency operation achieved by low Err
- \*No significant improvement is expected for critical conduction mode PFC as reverse recovery current from the diode does not influence the total conversion loss.

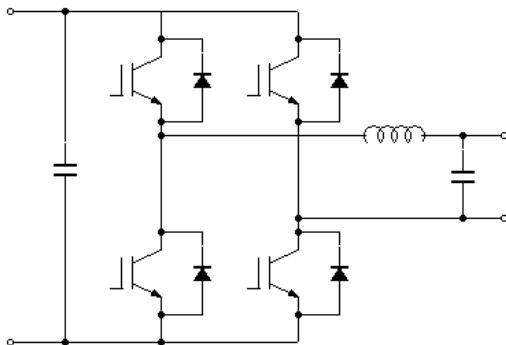


Recommended P/N

SCS2□□AM, SCS2□□AG,  
SCS2□□AE2, SCS2□□KG,  
SCS2□□KE2

### 9.2 Solar inverters

- Reduction in E<sub>off</sub>, Err and conduction loss at low load condition
- Downsizing of a cooling system for power devices

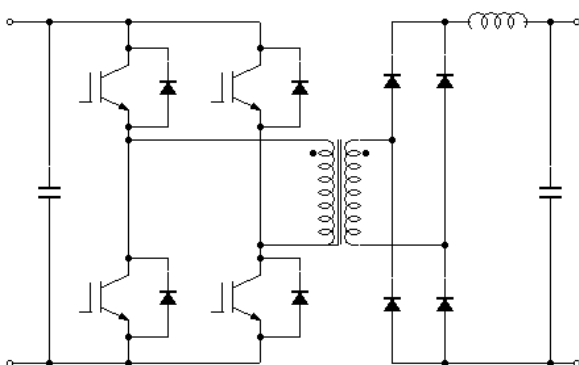


Recommended P/N

SCT2□□□KE, SCH2□□□KE  
BSM120D12P2C005,  
BSM180D12P2C101

### 9.3 DC/DC converters

- Reduction in E<sub>off</sub>, Err and downsizing of a cooling system for power devices
- Downsizing of transformer under high frequency operations



Recommended P/N (primary side)

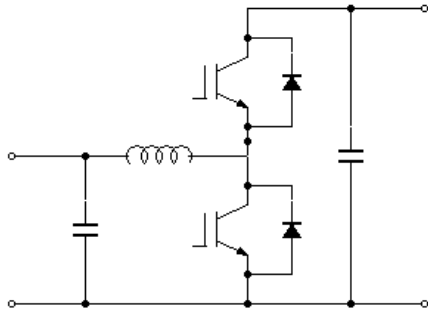
SCT2□□□KE, SCH2□□□KE  
BSM120D12P2C005,  
BSM180D12P2C101

Recommended P/N (secondary side)

SCS2□□AM, SCS2□□AG,  
SCS2□□AE2, SCS2□□KG,  
SCS2□□KE2

### 9.4 Bi-directional converters

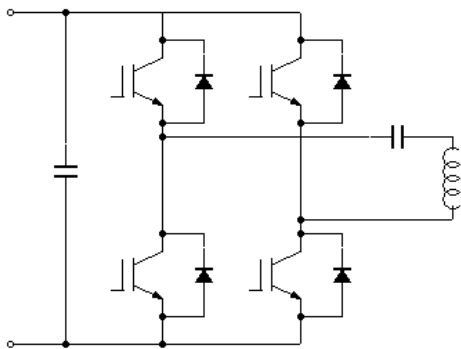
- Downsizing of passive filter components in high frequency operations
- Reduction in E<sub>eff</sub>, E<sub>err</sub> and size reduction of cooling system for power devices



Recommended P/N  
 SCT2□□□KE, SCH2□□□KE  
 BSM120D12P2C005,  
 BSM180D12P2C101

### 9.5 Inverters for induction heating equipment

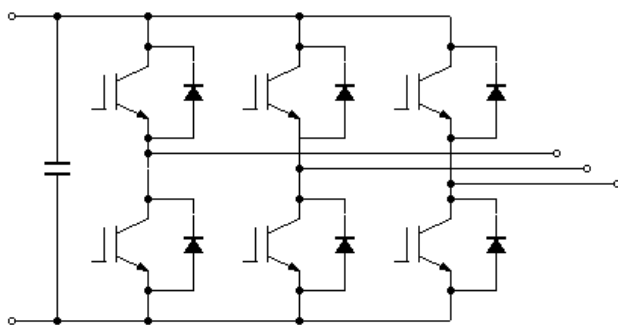
- Enlargement of operable conditions by increased frequency
- Reduction in E<sub>eff</sub>, E<sub>err</sub> and downsizing of a cooling system for power devices



Recommended P/N  
 SCT2□□□KE, SCH2□□□KE  
 BSM120D12P2C005,  
 BSM180D12P2C101

### 9.6 Motor drive inverters

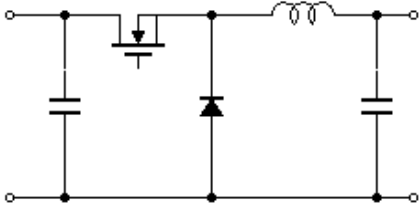
- Reduction in E<sub>eff</sub>, E<sub>err</sub> and downsizing of a cooling system for power devices



Recommended P/N  
 SCT2□□□KE, SCH2□□□KE  
 BSM120D12P2C005,  
 BSM180D12P2C101 他

## 9.7 Buck converters

- Reduction in  $E_{\text{off}}$  and downsizing of a cooling system for power devices
- Downsizing of passive filter components



Recommended P/N  
SCT2□□□KE  
SCS2□□AM, SCS2□□AG,  
SCS2□□AE2, SCS2□□KG,  
SCS2□□KE2

\*Buck converters operating in DCM (discontinuous conduction mode) and BCM (boundary conduction mode; also called critical conduction mode) do not benefit from SiC SBDs' recovery performance.

## Notes

- 1) The information contained herein is subject to change without notice.
- 2) Before you use our Products, please contact our sales representative and verify the latest specifications :
- 3) Although ROHM is continuously working to improve product reliability and quality, semiconductors can break down and malfunction due to various factors.  
Therefore, in order to prevent personal injury or fire arising from failure, please take safety measures such as complying with the derating characteristics, implementing redundant and fire prevention designs, and utilizing backups and fail-safe procedures. ROHM shall have no responsibility for any damages arising out of the use of our Products beyond the rating specified by ROHM.
- 4) Examples of application circuits, circuit constants and any other information contained herein are provided only to illustrate the standard usage and operations of the Products. The peripheral conditions must be taken into account when designing circuits for mass production.
- 5) The technical information specified herein is intended only to show the typical functions of and examples of application circuits for the Products. ROHM does not grant you, explicitly or implicitly, any license to use or exercise intellectual property or other rights held by ROHM or any other parties. ROHM shall have no responsibility whatsoever for any dispute arising out of the use of such technical information.
- 6) The Products specified in this document are not designed to be radiation tolerant.
- 7) For use of our Products in applications requiring a high degree of reliability (as exemplified below), please contact and consult with a ROHM representative : transportation equipment (i.e. cars, ships, trains), primary communication equipment, traffic lights, fire/crime prevention, safety equipment, medical systems, servers, solar cells, and power transmission systems.
- 8) Do not use our Products in applications requiring extremely high reliability, such as aerospace equipment, nuclear power control systems, and submarine repeaters.
- 9) ROHM shall have no responsibility for any damages or injury arising from non-compliance with the recommended usage conditions and specifications contained herein.
- 10) ROHM has used reasonable care to ensure the accuracy of the information contained in this document. However, ROHM does not warrant that such information is error-free, and ROHM shall have no responsibility for any damages arising from any inaccuracy or misprint of such information.
- 11) Please use the Products in accordance with any applicable environmental laws and regulations, such as the RoHS Directive. For more details, including RoHS compatibility, please contact a ROHM sales office. ROHM shall have no responsibility for any damages or losses resulting from non-compliance with any applicable laws or regulations.
- 12) When providing our Products and technologies contained in this document to other countries, you must abide by the procedures and provisions stipulated in all applicable export laws and regulations, including without limitation the US Export Administration Regulations and the Foreign Exchange and Foreign Trade Act.
- 13) This document, in part or in whole, may not be reprinted or reproduced without prior consent of ROHM.



Thank you for your accessing to ROHM product informations.  
More detail product informations and catalogs are available, please contact us.

## ROHM Customer Support System

<http://www.rohm.com/contact/>