

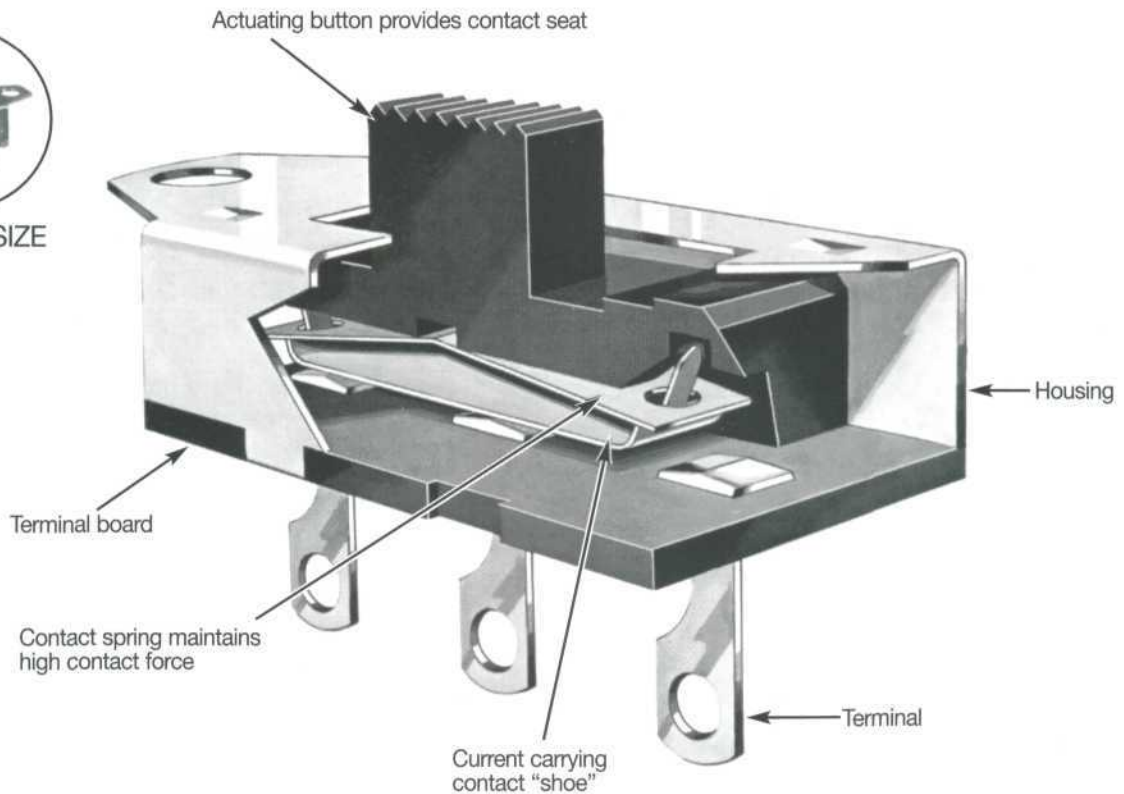

ACTUAL SIZE



## Design Features:

- Volume and circuit board area less than 20% of most conventional sized slide switches of similar circuitry
- Plug-in (PC board) or ear (panel) mounting
- One and two pole
- Two and three position
- Detented or spring return
- Reliable, yet moderately priced
- Low contact resistance

CW microminiature switches are designed to meet industry demand for tiny, yet reliable components at a moderate price. The extended linear motion of the moving contact over the relative closely spaced stationary contacts causes a full wiping and cleaning action of the contacts at each switch actuation. This helps maintain the reliability of the switch even in hostile environments. Where area and volume is limited... computers, thermostats, electronic controls and instruments, games and communication equipment... and reliability is essential... these switches are ideal.

The switches are made in CW's modern facilities... stamping, molding, machining, plating, and assembly. They are tested and retested in CW's laboratories to mechanical and electrical performance standards consistent with those described herein. CW maintains full control of all processes of conversion of raw material to finished product.

# TERMINAL OPTIONS

Five terminal styles are available as shown. Choose terminal that best suits your application from charts.

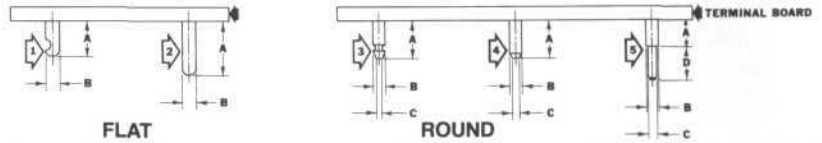

DIMENSION/ STYLE	G-20-55	G-20-57	G-20-58	G-20-74	G-20-29	G-20-104	G-20-139	G-20-140	G-20-32
A	.133 ± .010 (3.38 ± .25)	.093 ± .010 (2.36 ± .25)	.200 ± .010 (5.08 ± .25)	.178 ± .010 (4.52 ± .25)	.359 ± .010 (9.12 ± .25)	.284 ± .010 (7.21 ± .25)	.520 ± .010 (13.21 ± .25)	.349 ± .010 (8.86 ± .25)	.143 ± .010 (3.63 ± .25)
B	.050 (1.27)	.050 (1.27)	.050 (1.27)	.050 (1.27)	.050 1.27	.050 (1.27)	.050 (1.27)	.050 (1.27)	.043 ± .003 (1.09 ± .08)
C	-	-	-	-	-	-	-	-	.021 ± .005 (.53 ± .13)
D	-	-	-	-	-	-	-	-	-
Style No.	1	1	2	2	2	2	2	2	3

## GS-115 0.5 A at 125 Vac/Vdc

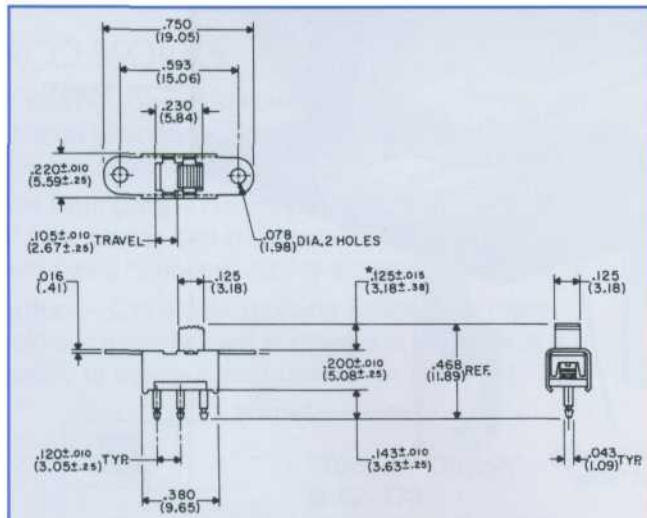

Terminal options are available from styles 3, 4, and 5.  
\*Button height and style shown are standard. Other heights available are .140" (3.56 mm) and .210" (5.33 mm). For additional styles and heights, see page 4.

## GS-115-PC 0.5 A at 125 Vac/Vdc

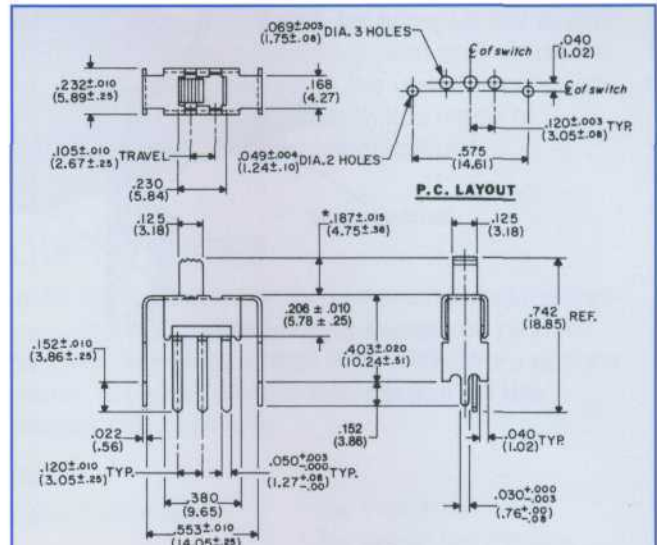

\*Button height and style shown are standard. For additional heights and styles, see page 4.

## GS-111 0.5 A at 125 Vac/Vdc GS-111-1 1.0 A ac, 0.5 A at 125 Vdc

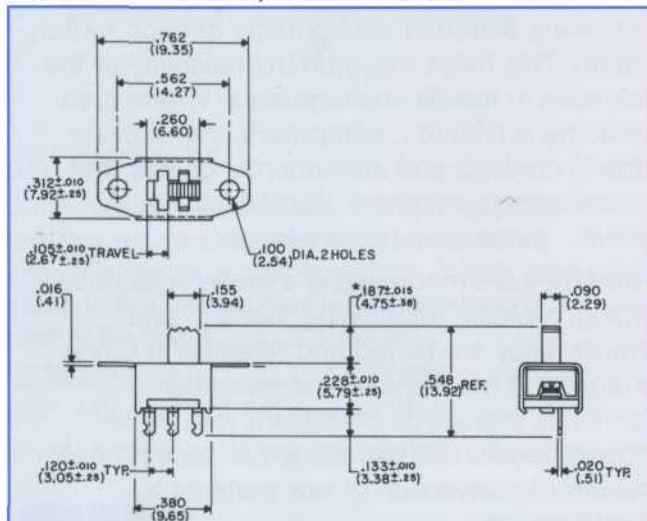

Terminal options are available from styles 1 and 2.  
\*Button height and style shown are standard. Other heights available are .342" (8.69 mm) and .500" (12.7 mm).

## GS-111-PC 0.5 A at 125 Vac/Vdc

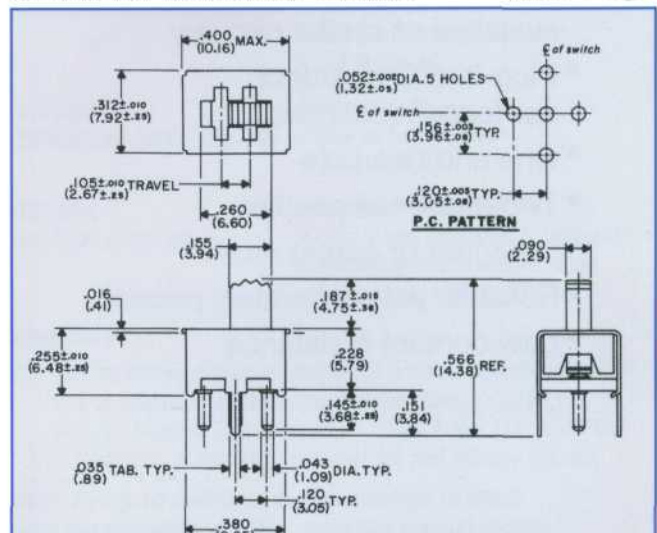

\*Button height and style shown are standard. Other heights available are .342" (8.69 mm) and .500" (12.7 mm).

DIMENSION/ STYLE	G-20-47	G-20-49	G-20-52	G-20-61	G-20-62	G-20-128
A	.046 ± .010 (1.17 ± .75)	.052 ± .010 (1.32 ± .25)	.100 ± .010 (2.54 ± .25)	.052 ± .010 (1.32 ± .25)	.087 ± .010 (2.21 ± .25)	.162 ± .010 (4.11 ± .25)
B	.043 ± .003 (1.09 ± .08)	.043 ± .003 (1.09 ± .08)	.043 ± .003 (1.09 ± .08)	.044 ± .003 (1.12 ± .08)	.043 ± .003 (1.09 ± .08)	.032 ± .003 (.81 ± .08)
C	.025 ± .005 (.64 ± .13)	.022 ± .005 (.56 ± .13)	.021 ± .005 (.53 ± .13)	.030 ± .005 (.76 ± .13)	.022 ± .005 (.56 ± .13)	.020 ± .005 (.51 ± .13)
D	-	.054 ± .005 (1.37 ± .13)	-	.054 ± .010 (1.37 ± 0.25)	.100 ± .010 (2.54 ± .25)	-
Style No.	4	5	3	5	5	4

GI-116 0.5 A at 125 Vac/Vdc

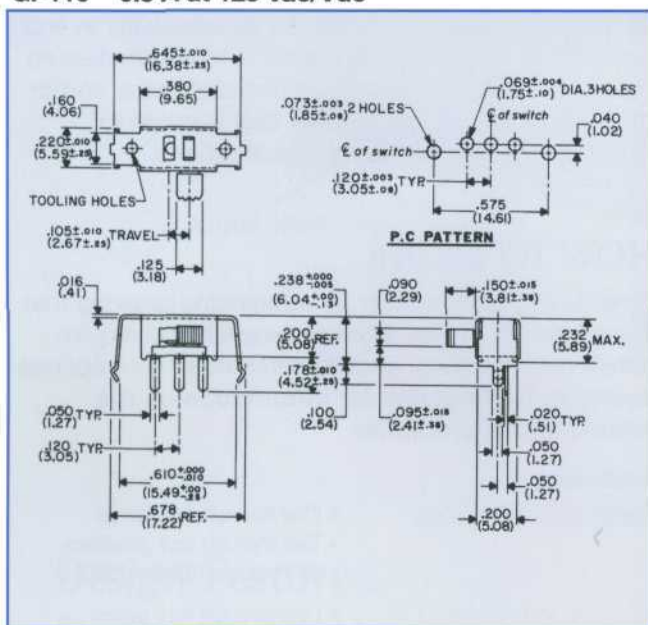

GS-100 0.5 A at 125 Vac/Vdc

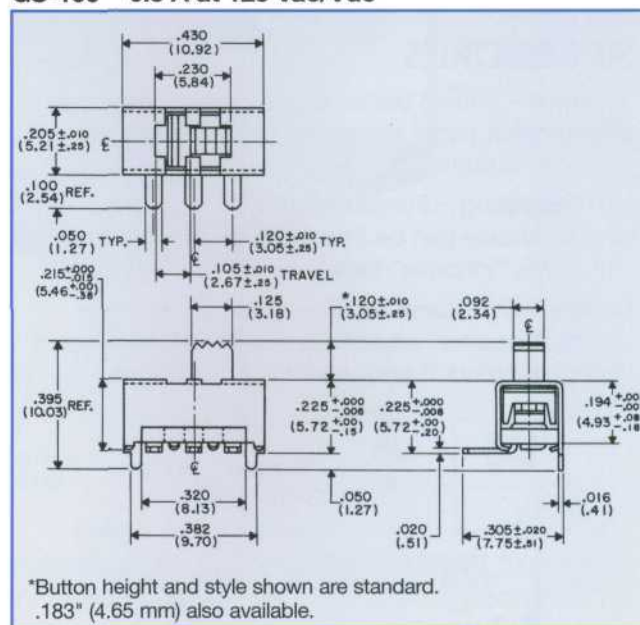

\*Button height and style shown are standard. .183" (4.65 mm) also available.

GS-113 0.5 A at 125 Vac/Vdc

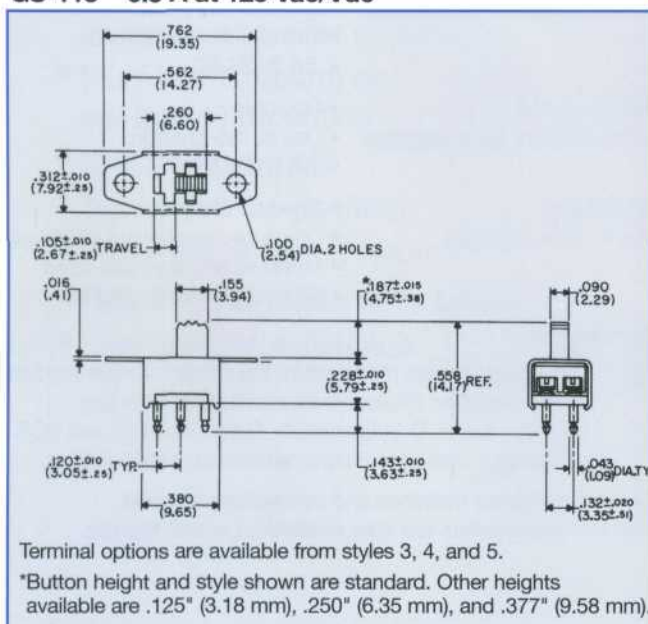

Terminal options are available from styles 3, 4, and 5.  
\*Button height and style shown are standard. Other heights available are .125" (3.18 mm), .250" (6.35 mm), and .377" (9.58 mm).

GS-113-PC 0.5 A at 125 Vac/Vdc

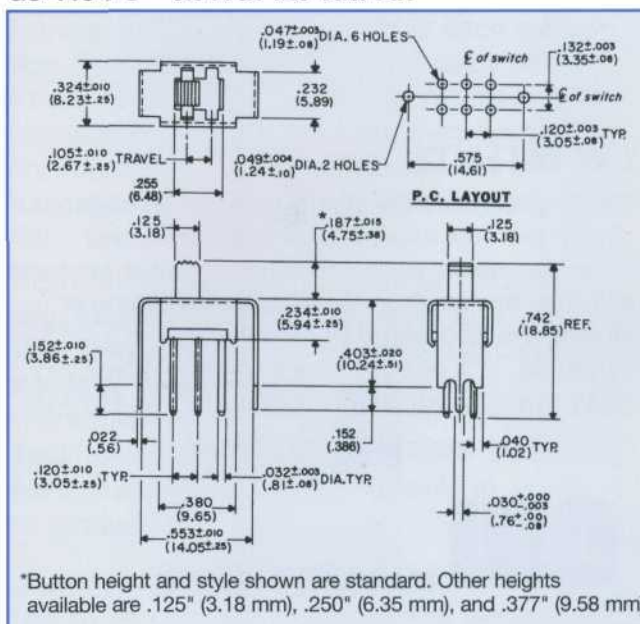

\*Button height and style shown are standard. Other heights available are .125" (3.18 mm), .250" (6.35 mm), and .377" (9.58 mm).

DIMENSION/ STYLE	G-20-63	G-20-64	G-20-73	G-20-78	G-20-85	G-20-90	G-20-95	G-20-102
A	.052 ± .010 (1.32 ± .25)	.077 ± .010 (1.96 ± .25)	.052 ± .010 (1.32 ± .25)	.031 ± .010 (.79 ± .25)	.243 ± .010 (6.17 ± .25)	.200 ± .010 (5.08 ± .25)	.286 ± .010 (7.26 ± .25)	.145 ± .010 (3.68 ± .25)
B	.044 ± .033 (1.12 ± .08)	.043 ± .003 (1.09 ± .08)	.044 ± .003 (1.12 ± .08)	.043 ± .003 (1.09 ± .08)	.043 ± .003 (1.09 ± .08)	.044 ± .003 (1.12 ± .08)	.043 ± .003 (1.09 ± .08)	.043 ± .003 (1.09 ± .08)
C	.030 ± .005 (.76 ± .13)	.025 ± .005 (.64 ± .13)	.030 ± .005 (.76 ± .13)	.022 ± .005 (.56 ± .13)	.021 ± .005 (.53 ± .13)	.030 ± .005 (.76 ± .13)	.022 ± .005 (.56 ± .13)	.025 ± .005 (.64 ± .13)
D	.08 ± .010 (2.03 ± .25)	—	.125 ± .005 (3.18 ± .13)	.066 ± .005 (1.68 ± .13)	—	.080 ± .005 (2.03 ± .13)	.054 ± .005 (1.37 ± .13)	—
Style No.	5	4	5	5	3	5	5	4

### GS-118 0.5 A at 125 Vac/Vdc

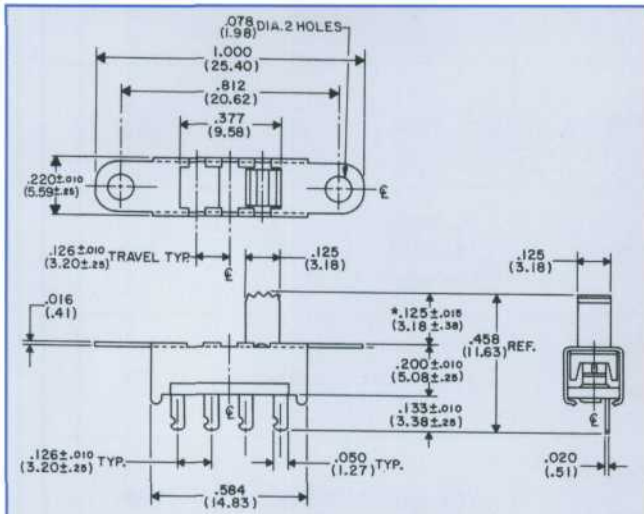

Terminal options are available from styles 1 and 2.

\*Button height and style shown are standard. Other heights available are .140" (3.56 mm) and .210" (5.33 mm). For additional styles and heights, see below.

### GS-118-PC 0.5 A at 125 Vac/Vdc

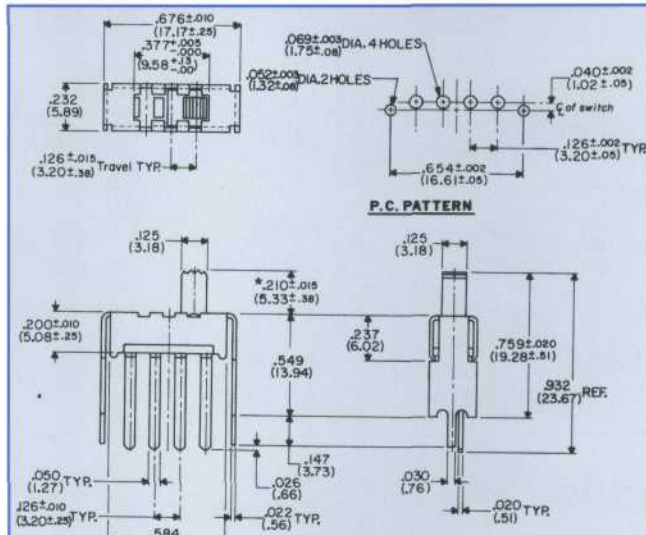

P.C. PATTERN

\*Button height and style shown are standard. Other heights available are .125" (3.18 mm) and .140" (3.56 mm). For additional styles and heights, see below.

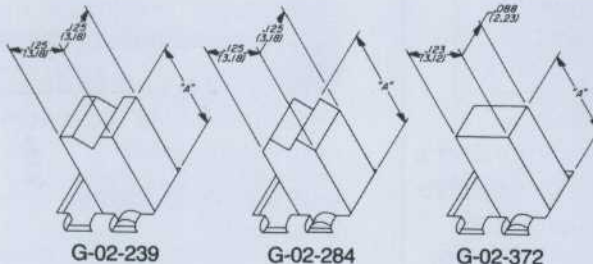

### Button options... for switches charted only

Button Part No.	Available "A" Dimension	GS-115	GS-115-0073	GS-118	GS-118-0008
G-02-239	.125, .140 .169	X	X	X	X
G-02-284	.197	X	X	X	X
G-02-372 for use with topper G-02-383	.147	X	X	X	X



For material specifications, accessories, and how to order, see back page.

## SELECTION GUIDE

Model No.	Ratings	Circuit	Mounting	Standard Terminals	Actuation
 GS-115	0.5 A at 125 Vac/Vdc	spdt with detent 	Panel	Pin	TOP
 GS-115-PC	0.5 A at 125 Vac/Vdc	spdt with detent 	PC board	Pin	TOP
 GS-111*  GS-111-1*	0.5 A at 125 Vac/Vdc 1.0 A ac 0.5 A at 125 Vdc	spdt with detent 	Panel	Flat	TOP
 GS-111-PC*	0.5 A at 125 Vac/Vdc	spdt with detent 	PC board	Pin	TOP
 GI-116	0.5 A at 125 Vac/Vdc	spdt with detent 	PC board	Flat	SIDE
 GS-100	0.5 A at 125 Vac/Vdc	spdt with detent 	PC board etched on one side	Flat	TOP
 GS-113	0.5 A at 125 Vac/Vdc	dpdt with detent 	Panel	Pin	TOP
 GS-113-PC	0.5 A at 125 Vac/Vdc	dpdt with detent 	PC board	Pin	TOP
 GS-118	0.5 A at 125 Vac/Vdc	sp-3-pos with detent 	Panel	Flat	TOP
 GS-118-0008	0.5 A at 125 Vac/Vdc	sp-3-pos with detent 	PC board	Flat	TOP

\*Recognized under the Component Recognition Program of Underwriter Laboratories, Inc. (UL File No. E9556) and certified by Canadian Standards Association (CSA File No. LR20985)

### PERFORMANCE STANDARDS<sup>+</sup>

CW switches are designed and manufactured to perform when subjected to the following conditions: Operating temperature – 104°C ambient maximum.

**Relative humidity** – After 100 hours in an atmosphere having 95% relative humidity and a temperature of 50°C, switches will be operative and insulation resistance will be greater than 100 megohms between contacts and housing, if allowed to dry for a period of one hour at 25°C (room temperature).

**Life cycling (no load)** – Switches will be operative after 10,000 (minimum) cycles at the rate of 10 cycles per minute at rated load.

**High-voltage breakdown** – Minimum of 1000 volts rms 60 Hz for one minute between parts of opposite polarity.

**Contact resistance** – Less than 0.01 ohms at 20 mAdc.

<sup>+</sup>Performance specifications and materials described herein are general specifications that vary depending on the switch construction specified and end application. Consult factory for specifications for specific models. Specifications subject to change without notice.

## MATERIALS OF CONSTRUCTION<sup>+</sup>

**Actuator** – Type 6/6 black nylon, other colors available

**Housing** – Cold-rolled steel, plated

**Housing plating** – Panel: zinc, PC board: Electro-tin

**Terminal board** – N.E.M.A. Grade XP Phenolic Laminate

**Terminals** – Copper, silver-plated

**Moving contact** – Copper alloys, silver-plated

**Contact spring** – Beryllium copper or phosphor bronze

<sup>+</sup>Materials described herein are general specifications that vary depending on the switch construction specified and end application. Consult factory for specifications for specific models. Specifications subject to change without notice.

## ACCESSORIES

**Toppers** – Shown below is the “Topper” that can change your panel appearance and product styling. Fits onto button.

**Hot Stamping** – Functional or decorative marking of your choice can be imprinted on “Topper” surface with CW’s “inhouse” facilities.

**Colors** – CW stores molding powders in many colors. “Toppers” and buttons are available in a variety of colors if your quantity is sufficient.

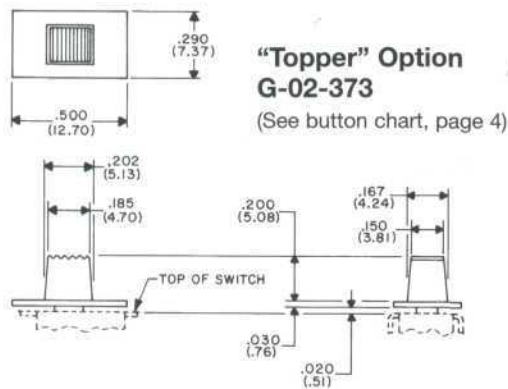

## CW PATENTS

CW Engineers are constantly trying to upgrade the quality and cost effectiveness of our switches. Often this results in new inventions. Switch products shown in this catalog may be covered by one or more of the following U.S. Patents:

3,270,149    3,993,881    3,271,535    4,404,437  
3,311,719    4,128,745    3,461,252    4,410,232

Other patent applications are pending.

**CW**  
**INDUSTRIES**

130 James Way, Southampton, PA 18966-3838 • Tel. 215-355-7080 • Fax 215-355-1088 • www.cwind.com

## CARE IN USE OF SWITCHES

CW switches will perform properly if they are installed and used properly. Causes for failure often encountered in the field that are the responsibility of the user are:

1. Removal of factory applied lubricants from switch contacts and moving parts.
2. Introduction of foreign material into switching mechanism... flux, solder, cleaning materials, and potting compounds.
3. Restriction of movement of switch button.
4. Excessive heat often introduced while soldering.
5. Switching loads in excess of rating.

Users are cautioned to avoid misusing switches and to test and approve switches for acceptability in end application. CW has no knowledge of and makes no representation with respect to the usefulness and/or merchantability of any product that is made to buyer's special engineering specifications.

## HOW TO ORDER

Specify CW part number by referencing drawing that shows switch of your choice. If switch you require differs from drawing, specify differences from options available. **Contact CW for information on the following CW products:**

### Switches

#### Standard Slide Switches:

- One through four poles
- Two through four positions
- 3A through 13A @ 125V AC

#### Miniature Slide Switches:

- One through four poles
- Two through four positions
- 3A through 13A @ 125V AC

#### MicroMiniature Slide Switches:

- One and two poles
- Two and three positions
- .5A @12V AC

#### Fully Enclosed

- One pole

#### Microminiature Slide Switches:

- One or two position
- .5A @12V AC

#### Rocker and

#### Power Slide Switches:

- One and two poles
- One & two positions & center-off
- Miniature and standard sized
- 8A through 16A @125V AC

### Connectors

IDC: CW Industries also manufactures a comprehensive product line of insulation displacement connectors, including Socket, Header, D-Subminiature, Card Edge, DIP, and PCB connectors. Available in commercial and military grades.

**Custom designed switches and connectors to meet special requirements are also available; consult factory.**