

**Circuits
from the Lab[®]**
Reference Designs

Circuits from the Lab[®] reference designs are engineered and tested for quick and easy system integration to help solve today's analog, mixed-signal, and RF design challenges. For more information and/or support, visit www.analog.com/CN0287.

Devices Connected/Referenced	
AD7193	4-Channel, 4.8 kHz, Ultralow Noise, 24-Bit Sigma-Delta ADC with PGA
ADT7310	±0.5°C Accurate, 16-Bit Digital SPI Temperature Sensor
AD8603	Precision Micropower, Low Noise CMOS R-to-R Input/Output Operational Amplifiers
ADR3440	4.096 V, Micropower High Accuracy Voltage Reference
ADG738	CMOS, Low Voltage, 3-Wire Serially-Controlled, Matrix Switch
ADG702	CMOS Low Voltage 2 Ω SPST Switch
AD5201	33-Position Digital Potentiometer
ADuM1280	3 kV RMS Dual Channel Digital Isolators
ADuM5401	Quad-Channel, 2.5 kV Isolators with Integrated DC-to-DC Converter

Isolated 4-Channel, Thermocouple/RTD Temperature Measurement System with 0.5°C Accuracy

EVALUATION AND DESIGN SUPPORT

Circuit Evaluation Boards

[CN-0287 Circuit Evaluation Board \(EVAL-CN0287-SDPZ\)](#)
[System Demonstration Platform \(EVAL-SDP-CB1Z\)](#)

Design and Integration Files

[Schematics](#), [Layout Files](#), [Bill of Materials](#)

CIRCUIT FUNCTION AND BENEFITS

The circuit shown in Figure 1 is a completely isolated 4-channel temperature measurement circuit optimized for performance, input flexibility, robustness, and low cost. It supports all types of thermocouples with cold junction compensation and any type of RTD (resistance temperature detector) with resistances up to 4 kΩ for 2-, 3-, or 4-wire connection configurations.

The RTD excitation current are is programmable for optimum noise and linearity performance.

RTD measurements achieve 0.1°C accuracy (typical), and Type-K thermocouple measurements achieve 0.05°C typical accuracy because of the 16-bit [ADT7310](#) digital temperature sensor used for cold-junction compensation. The circuit uses a four-channel [AD7193](#) 24-bit sigma-delta ADC with on-chip PGA for high accuracy and low noise.

Input transient and overvoltage protection are provided by low leakage transient voltage suppressors (TVS) and Schottky diodes. The SPI-compatible digital inputs and outputs are isolated (2500 V rms), and the circuit is operated on a fully isolated power supply.

Rev. C

Circuits from the Lab[®] reference designs from Analog Devices have been designed and built by Analog Devices engineers. Standard engineering practices have been employed in the design and construction of each circuit, and their function and performance have been tested and verified in a lab environment at room temperature. However, you are solely responsible for testing the circuit and determining its suitability and applicability for your use and application. Accordingly, in no event shall Analog Devices be liable for direct, indirect, special, incidental, consequential or punitive damages due to any cause whatsoever connected to the use of any Circuits from the Lab circuits. (Continued on last page)

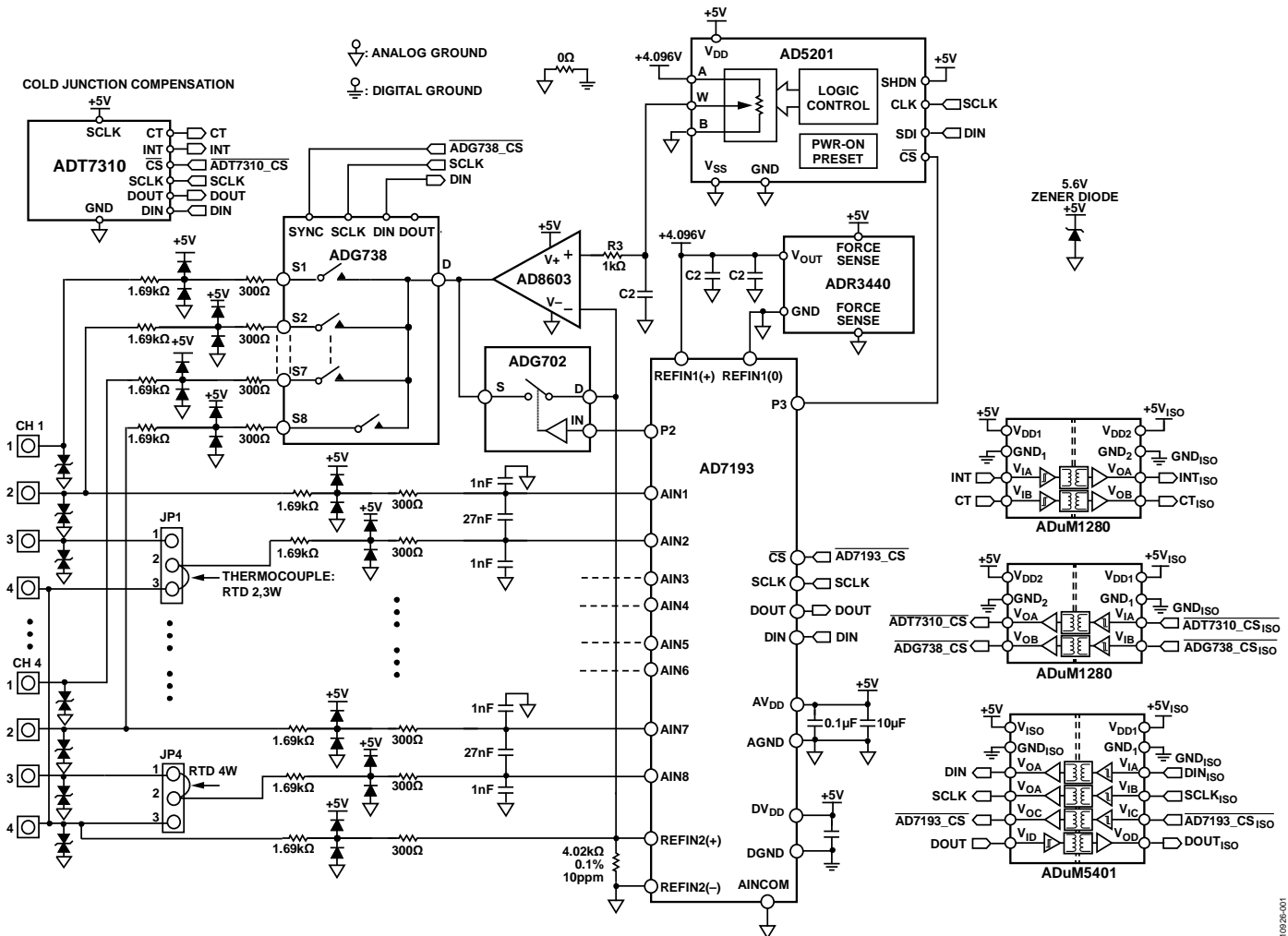

Figure 1. 4-Channel Thermocouple and RTD Circuit (Simplified Schematic: All Connections and Decoupling Not Shown)

CIRCUIT DESCRIPTION

Temperature Measurement Introduction

Thermocouples and RTDs (resistance temperature detectors) are the most frequently used sensors for temperature measurement in industrial applications. Thermocouples are able to measure very high temperatures up to about +2300°C and also have a fast response time (measured in fractions of a second). RTDs are capable of higher accuracy and stability than thermocouples, and the resistance of long wire lengths (hundreds of meters) to a remote RTD can be compensated for with 3- or 4-wire connections.

A thermocouple consists of two wires of different metals joined at one end. This end is placed at the temperature which is to be measured, referred to as the measurement junction. The other end is connected to a precision voltage measurement unit, and this connection is referred to as the reference junction or alternately the cold junction. The temperature difference between the measurement junction and the cold junction generates a voltage (known as the Seebeck effect voltage) that is related to the difference between the temperatures of the two junctions. The

signal generated is typically from several microvolts to tens of millivolt depending on the temperature difference.

For example, K-type thermocouples are capable of measuring -200°C to +1350°C with an output range of approximately -10 mV to +60 mV. It is important for the signal chain to maintain as high impedance and low leakage as possible to achieve the highest accuracy for the voltage measurement. In order to convert this voltage to an absolute temperature, the cold junction temperature must be accurately known. Traditionally 1°C to 2°C has been considered sufficient, although since the cold junction measurement error contributes directly to the absolute temperature error, a higher accuracy cold junction temperature measurement is beneficial

An RTD is made from a pure material, such as platinum, nickel or copper, that has a predictable change in resistance as the temperature changes. The most widely used RTD is platinum (Pt100 and Pt1000).

One method used to accurately measure the resistance is to measure the voltage across the RTD generated by a constant current source. Errors in the current source can be cancelled by referring the measurement to the voltage generated across a

Temperature measurement is a high precision and low speed application, therefore there is adequate settling time available to switch the single current source between all 4 channels, providing excellent channel-to-channel matching, low cost, and small PCB footprint.

The ADG738 is an 8-to-1 multiplexer that switches the current source between channels. In order to support the 2-, 3-, and 4-wire RTD configurations, each of the four channels need two switches.

In many applications, the RTD may be located remotely from the measurement circuit. The resistance from the long lead wires can generate large errors, especially for low resistance RTDs. In order to minimize the effect of the lead resistance, a 3-wire RTD configuration is supported as shown in Figure 3.

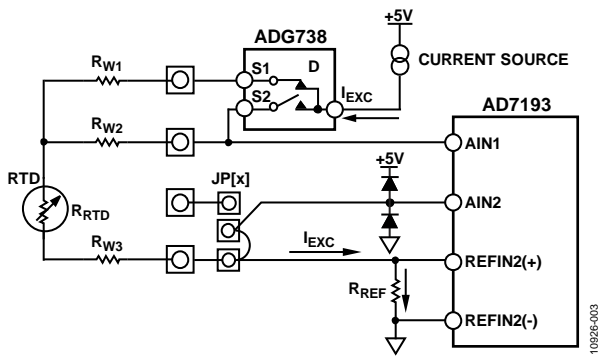

Figure 3. Connector and Jumper Configuration for 3-Wire RTD Sensor

With S1 of the ADG738 closed and S2 opened, the voltage at the input of AD7193 is V_1 . With S1 opened and S2 closed, the voltage on the input of AD7193 is V_2 . The voltage across the RTD sensor is V_{RTD} , the exciting current from the current source is I_{EXC} . V_1 and V_2 contain the error generated by the lead resistance as shown below:

$$V_1 = (R_{RTD} + R_{W3}) \times I_{EXC} \tag{1}$$

$$V_2 = (R_{W2} + R_{RTD} + R_{W3}) \times I_{EXC} \tag{2}$$

$$V_{RTD} = R_{RTD} \times I_{EXC} \tag{3}$$

Assuming $R_{W1} = R_{W2} = R_{W3}$ and combining Equations 1, 2, and 3 yields:

$$V_{RTD} = 2V_1 - V_2 \tag{4}$$

$$R_{RTD} = V_{RTD}/I_{EXC} = (2V_1 - V_2)/I_{EXC} \tag{5}$$

Equation 5 shows that the 3-wire configuration requires two separate measurements (V_1 and V_2) in order to calculate R_{RTD} , thereby decreasing the output data rate. In most applications this is not a problem.

The 4-wire RTD connection requires two extra sense lines, but is insensitive to wiring resistances and only requires one measurement.

Figure 4 summarizes the connector configuration and jumper placements for RTD 2-wire, RTD 3-wire, RTD 4-wire, and thermocouple applications.

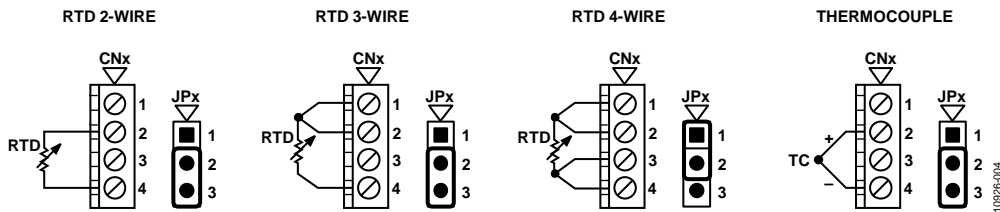

Figure 4. Connector Configuration and Jumper Placements for EVAL-CN0287-SDPZ Board

Protection Circuits

Transient and overvoltage conditions are possible both during manufacturing and in the field. To achieve a high level of protection, additional external protection circuitry is necessary to compliment the IC’s internal integrated protection circuitry. The external protection adds additional capacitance, resistance, and leakage. These effects should be carefully considered to achieve a high level of accuracy. The additional protection circuitry is shown in Figure 5.

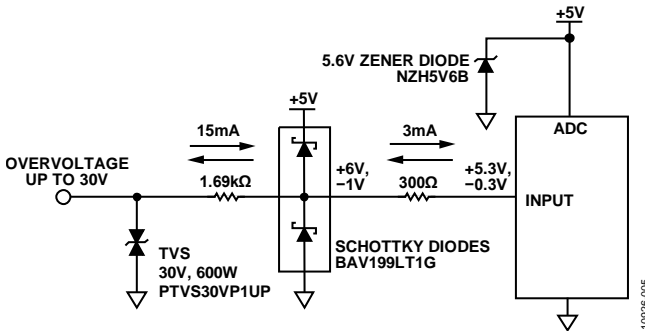

Figure 5. Transient and Overvoltage Protection Circuit

Leakage currents can have a significant effect on RTD measurements so should be carefully considered. Leakage currents can also create some error in thermocouple measurements in the case where long thermocouple leads have significant resistance.

In this circuit, the PTVS30VP1UP transient voltage suppressor (TVS) quickly clamps any transient voltages to 30 V with only 1 nA typical leakage current at 25°C. A 30 V TVS was chosen to allow for a 30 V dc overvoltage. A 1.69 kΩ resistor followed by low leakage BAV199LT1G Schottky diodes are used to clamp the voltage to the 5 V power rail during transient and dc overvoltage events. The 1.69 kΩ resistor limits the current through the external diodes to about 15 mA during a 30 V dc overvoltage condition. In order to ensure the power rail is able to sink this current, a Zener diode is used to clamp the power rail to ensure it does not exceed the absolute maximum rating of any of the IC’s connected to the supply. The 5.6 V Zener diode (NZH5V6B) is selected for this purpose. A 300 Ω resistor limits any further current that could flow into the AD7193 or the ADG738.

Isolation

The ADuM5401 and the ADuM1280 use ADI iCoupler® technology provide 2500 V rms isolation voltage between the measurement side and the controller side of the circuit. The ADuM5401 also provides the isolated power for measurement side of the circuit. The isoPower technique used in the ADuM5401 uses high frequency switching elements to transfer power through a transformer. Special care must be taken with the printed circuit board (PCB) layout to meet emissions standards. Refer to AN-0971 Application Note for board layout recommendations.

Thermocouple Configuration Test Results

The performance of the circuit is highly dependent on the sensor and the configuration of the AD7193. The Type-K thermocouple output varies from –10 mV to +60 mV, corresponding to –200°C to +1350°C. The AD7193 PGA is configured for G = 32. The voltage swing out of the PGA is –320 mV to +1.92 V, or 2.24 V p-p. With chop enabled, 50 Hz/60Hz noise reduction enabled, and filter word FS[9:0] = 96, the noise distribution histogram for 1024 samples is shown in Figure 6.

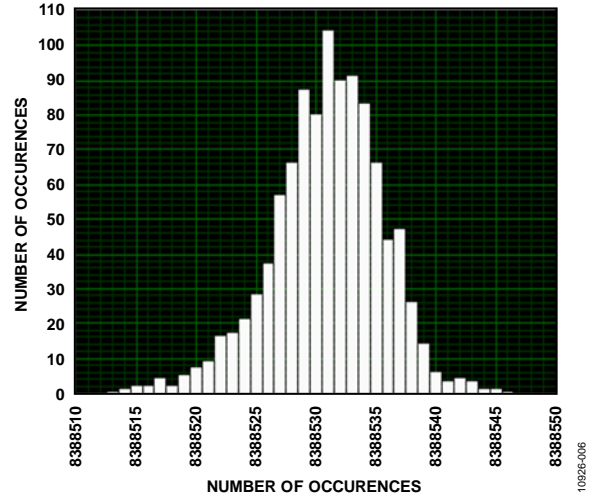

Figure 6. Noise Distribution Histogram of CN-0287 (VDD = 5 V, VREF = 4.096 V, Differential Input, Bipolar, Input Buffer Enable, Output Data rate = 50 Hz, Gain = 32, Chop Enable, 60 Hz Rejection Enable, Sinc⁴)

The resolution of the AD7193 is 24 bits, or 2²⁴ = 16,777,216 codes. The full dynamic range of the AD7193 is 2 × V_{REF} = 2 × 4.096 V = 8.192 V. The output voltage of the thermocouple after the PGA is only 2.24 V p-p and does not occupy all the dynamic range of the AD7193. Therefore the range of the system is decreased by a factor of 2.24 V/8.192V.

The noise distribution is about 40 codes peak-to-peak. The noise-free code resolution over the 2.24 Vp-p range of measurement is given by:

$$\text{Noise Free Resolution} = \log_2 \left(\frac{16,777,216}{400} \times \frac{2.24 \text{ V}}{8.192 \text{ V}} \right) \quad (6)$$

$$= 16.8 \text{ bits}$$

The full-scale temperature range of the Type-K thermocouple is –200°C to +1350°C, or 1550°C p-p. The 16.8 bits of noise-free code resolution therefore corresponds to 0.013°C of noise-free temperature resolution.

Thermocouple Measurement Linearity

Figure 7 shows the approximate linearity of the type K thermocouple system. The “cold junction” temperature is 0°C in this plot.

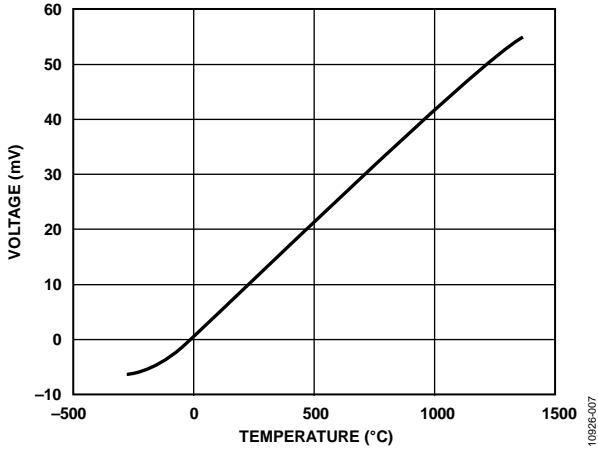

Figure 7. Type K Thermocouple Temperature vs. Output Voltage with 0°C Cold-Junction

The precision voltage for calibration as well as testing is provided by the Fluke 5700A Calibrator high precision dc voltage source with a resolution of 10 nV. The voltage error in Figure 8 is within 0.2 μV of ideal, corresponding to about 0.004°C. This result is the short time accuracy result just after a system calibration at 25°C without the effects of temperature drift. The dominant error for this circuit is from the cold-junction compensation measurement. In this circuit the ADT7310 is used for cold-junction compensation and has a typical error of -0.05°C, and a worst case error of ±0.8°C over the -40°C to +105°C temperature range for a 5 V supply. The device has a ±0.4°C maximum error over this temperature range if a 3 V supply is used.

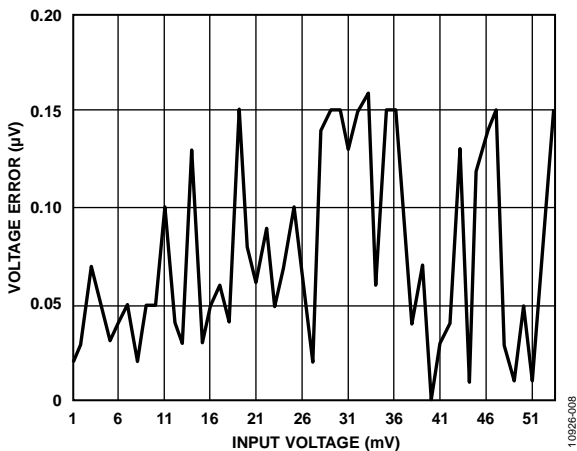

Figure 8. Error of CN-0287 Configured for Type K Thermocouple (VDD = 5 V, VREF = 4.096 V, Differential Input, Bipolar, Input Buffer Enable, Output Data Rate = 50 Hz, Gain = 32, Chop Enable, 60 Hz Rejection Enable, Sinc⁴)

RTD Configuration Test Results

For a Pt100 RTD, the default ADC gain setting is G = 8, and for a Pt1000 RTD the default gain setting is G = 1. The reference voltage to the ADC is equal to the voltage across the 4.02 kΩ reference resistor. The temperature coefficient of a Pt100 RTD is approximately 0.385 Ω/°C, and at +850°C the resistance can be as high as 400 Ω. With a 400 μA default excitation current, the maximum RTD voltage is therefore about 160 mV. The reference voltage to the ADC is 4.02 kΩ × 400 μA = 1.608 V. For G = 8, the maximum RTD voltage is 160 mV × 8 = 1.28 V which is approximately 80% of the available range.

For a Pt1000 RTD, the maximum resistance at +850°C is approximately 4000 Ω. The default excitation current is 380 μA, yielding a maximum RTD voltage of 1.52 V. The reference voltage to the ADC is 4.02 kΩ × 380 μA = 1.53 V. A default gain setting of G = 1 is used, and the maximum RTD voltage utilizes nearly all of the available range.

The general expression for the RTD resistance, R, in terms of the ADC code (Code), resolution (N), reference resistor (R_{REF}), and gain (G) is given by:

$$R = \frac{Code}{2^N} \left(\frac{R_{REF}}{G} \right) \tag{7}$$

The leakage current from TVS, diodes, clamping diodes, and ADC are the largest sources of errors in the RTD measurement circuit, even though nanoamp devices were selected for the design.

The total leakage current for each of the inputs is 9 nA (3 nA from AD7193, buffer on), 5 nA from clamping diode and 1 nA from the TVS diode). All four channels will thus generate 36 nA maximum leakage current. The feedback loop in Figure 2 maintains a constant current through the reference resistor. This means that leakage currents affect the RTD excitation current, thereby producing an error. The default exciting current is 400 μA for Pt100 and 380 μA for Pt1000. The approximate worst case system error due to the leakage currents for Pt100 RTDs is:

$$Error(\%) = \left(\frac{36 \text{ nA}}{400 \text{ μA}} \right) \times 100 \approx 0.01\% \text{ of reading} \tag{8}$$

For a Pt100 with measurable range from -200°C to +850°C, this corresponds to a system accuracy of approximately

$$Accuracy(C^\circ) = \frac{400 \text{ Ω}}{0.385 \text{ Ω/C}^\circ} \times 0.0001 \approx 0.1C^\circ \tag{9}$$

The amount of the error depends on the configuration of the input terminals. After an input configuration is established, a room temperature calibration can reduce the error even further.

An experiment was conducted to show the effects of leakage current. Each channel was first configured as a 4-W RTD. A 100 Ω fixed resistor was connected to Channel 1 in the RTD position. Zero ohm resistors were connected to the inputs of the other three channels.

The gain was set for $G = 1$, and the excitation current for $380 \mu\text{A}$ (Pt1000 configuration).

Data was collected, then the jumpers connecting Channel 4, Channel 3, and Channel 2 were removed sequentially, and data collected for each condition. The results are shown in Figure 9.

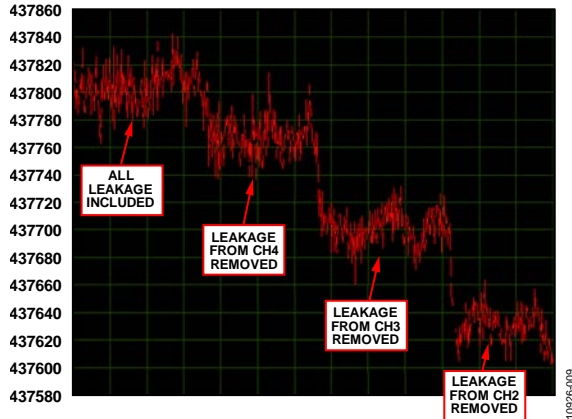

Figure 9. Error Generated by Leakage Current on Channel 1 for 4-Channel Pt100 RTD with $G = 1$

The ADC code changed from approximately 437,800 to 437,600 corresponding to a measurement change of 104.9015Ω to 104.8627Ω , or 0.0388Ω . This represents a measurement error of approximately 0.1°C ; however it can be removed by calibrating at room temperature with a fixed input configuration.

COMMON VARIATIONS

The AD779x low noise, low power, 16-/24-bit sigma-delta ADC family is more suitable for single channel or low power applications. The ADT7311, $\pm 0.5^\circ\text{C}$ accurate, 16-bit digital SPI temperature sensor is qualified for automotive applications. The cold junction compensation circuit accuracy can be improved by using a digital temperature sensor, such as ADT7320, with $\pm 0.25^\circ\text{C}$ accuracy.

RMS isolation up to 5 kV is available in the ADuM6401 digital isolator with dc-to-dc converter.

CIRCUIT EVALUATION AND TEST

This circuit uses the EVAL-CN0287-SDPZ circuit board and the SDP-B (EVAL-SDP-CB1Z) system demonstration platform controller board. The two boards have 120-pin mating connectors, allowing for the quick setup and evaluation of the performance of the circuit. The EVAL-CN0287-SDPZ board contains the circuit to be evaluated, as described in this note, and the SDP-B controller board is used with the CN-0287 Evaluation Software to capture the data from the EVAL-CN0287-SDPZ circuit board.

Equipment Needed

The following equipment is needed:

- A PC with a USB port and Windows® XP (32 bit), Windows Vista®, or Windows® 7
- The EVAL-CN0287-SDPZ circuit board
- The EVAL-SDP-CB1Z SDP-B controller board

- The CN-0287 SDP Evaluation Software
- The EVAL-CFTL-6V-PWRZ dc power supply or equivalent 6 V/1 A bench supply
- A RTD or thermocouple sensor or sensor simulator. (The evaluation software supports the following RTDs: Pt100, Pt1000; Thermocouple: Type K, Type J, Type T, Type S.)

Getting Started

Install the evaluation software by placing the CN-0287 Evaluation Software into the CD drive of the PC. Using My Computer, locate the drive that contains the evaluation software.

Functional Block Diagram

See Figure 1 for the circuit block diagram and the EVAL-CN0287-SDPZ-PADSSchematic.pdf file for the complete circuit schematic. This file is contained in the CN0287 Design Support Package located at www.analog.com/CN0287-DesignSupport A functional block diagram of the test setup is shown in Figure 10.

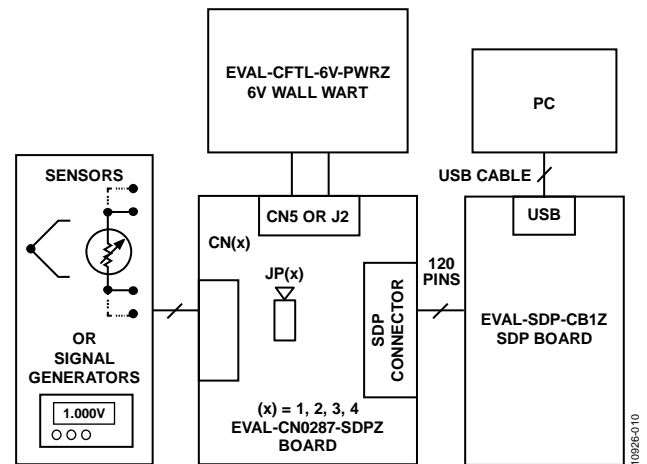

Figure 10. Test Setup Functional Block Diagram

Setup

Connect the 120-pin connector on the EVAL-CN0287-SDPZ circuit board to the CON A connector on the EVAL-SDP-CB1Z controller board (SDP-B). Use nylon hardware to firmly secure the two boards, using the holes provided at the ends of the 120-pin connectors. With power to the supply off, connect a 6 V power supply to the +6 V and GND pins on the board. If available, a 6 V wall wart can be connected to the barrel connector J2 on the board and used in place of the 6 V power supply. Connect the USB cable supplied with the SDP-B board to the USB port on the PC. Do not connect the USB cable to the Mini-USB connector on the SDP-B board at this time.

Turn on the 6 V power supply to power up the evaluation board and SDP board, then plug in the Mini-USB cable into the Mini-USB port on the SDP board.

Test

Launch the evaluation software. After USB communications are established, the SDP-B board can be used to send, receive, and capture data from the [EVAL-CN0287-SDPZ](#) board.

Figure 11 shows a photo of the [EVAL-CN0287-SDPZ](#) evaluation board connected to the SDP board. Information regarding the SDP-B board can be found in the [SDP-B User Guide](#).

Information and details regarding test setup and calibration, and how to use the evaluation software for data capture can be found in the [CN-0287 Software User Guide](#).

Connectivity for Prototype Development

The [EVAL-CN0287-SDPZ](#) evaluation board is designed to use the [EVAL-SDP-CB1Z](#) SDP-B board; however, any microprocessor can be used to interface to the SPI interface through the PMOD connector J6. The pin definition of PMOD connector can be found in the schematics of CN0287 evaluation board in [CN-0287 Design Support Package](#). In order for another controller to be used with the [EVAL-CN0287-SDPZ](#) evaluation board, software must be developed by a third party.

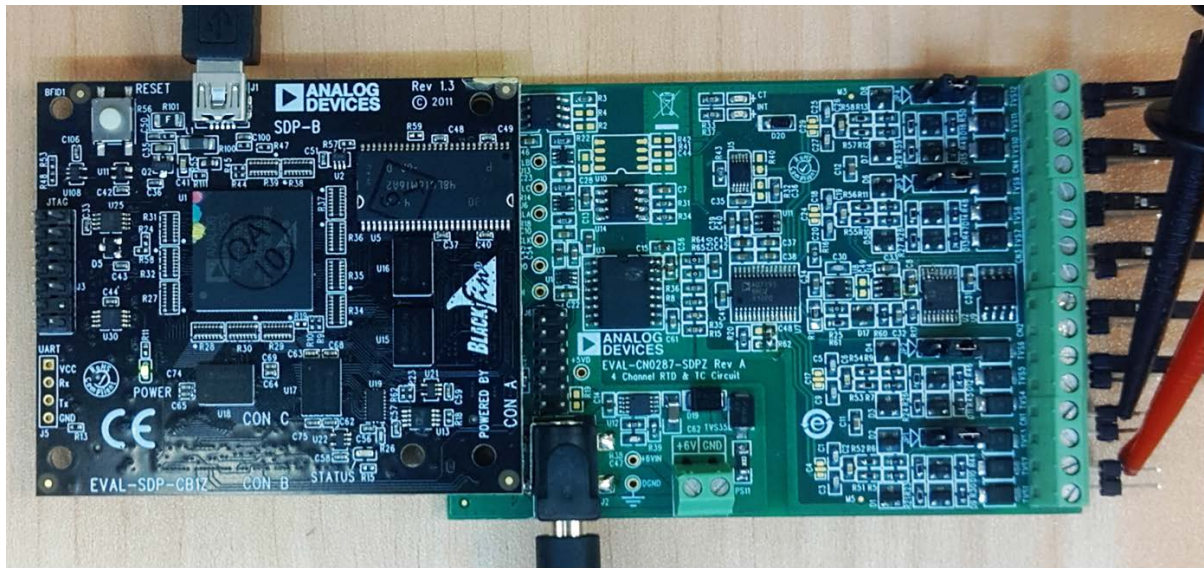

Figure 11. [EVAL-CN0287-SDPZ](#) Evaluation Board Connected to the [EVAL-SDP-CB1Z](#) SDP-B Board

10926-011

LEARN MORE

CN-0287 Design Support Package:
www.analog.com/CN0287-DesignSupport

SDP-B User Guide

AN-880 Application Note, *ADC Requirements for Temperature Measurement*, Analog Devices.

AN-892 Application Note, *Temperature Measurement Theory and Practical Techniques*, Analog Devices.

AN-0970 Application Note, *RTD Interfacing and Linearization Using an ADuC706x Microcontroller*, Analog Devices.

CN-0172, *High Accuracy Multichannel Thermocouple Measurement Solution*, Analog Devices.

CN-0206, *Complete Type T Thermocouple Measurement System with Cold Junction Compensation*, Analog Devices.

CN-0209, *Fully Programmable Universal Analog Front End for Process Control Applications*, Analog Devices.

CN-0221, *USB-Based Temperature Monitor Using the ADuCM360 Precision Analog Microcontroller and an External Thermocouple*, Analog Devices.

CN-0271, *K-Type Thermocouple Measurement System with Integrated Cold Junction Compensation*, Analog Devices.

Kester, Walt. 1999. *Sensor Signal Conditioning*. Analog Devices. Chapter 7, "Temperature Sensors."

Matthew Duff and Joseph Towey. *Two Ways to Measure Temperature Using Thermocouples Feature Simplicity, Accuracy, and Flexibility*, Analog Dialogue 44-10, Analog Devices.

Mary McCarthy, AN-615 Application Note, *Peak-to-Peak Resolution Versus Effective Resolution*.

MT-049 Tutorial, *Op Amp Total Output Noise Calculations for Single-Pole System*. Analog Devices.

MT-004 Tutorial, *The Good, the Bad, and the Ugly Aspects of ADC Input Noise—Is No Noise Good Noise?* Analog Devices.

MT-031 Tutorial, *Grounding Data Converters and Solving the Mystery of "AGND" and "DGND"*, Analog Devices.

MT-035, *Op Amp Inputs, Outputs, Single-Supply, and Rail-to-Rail Issues*, Analog Devices.

MT-101 Tutorial, *Decoupling Techniques*, Analog Devices.

Data Sheets and Evaluation Boards

CN-0287 Circuit Evaluation Board (EVAL-CN0287-SDPZ)
 System Demonstration Platform (EVAL-SDP-CB1Z)

AD7193 Datasheet

AD8603 Datasheet

ADG738 Datasheet

ADG702 Datasheet

ADT7310 Datasheet

ADuM5401 Datasheet

ADuM1280 Datasheet

AD5201 Datasheet

ADR3440 Datasheet

REVISION HISTORY

2/14—Rev. B to Rev. C	
Change to Common Variations Section	7
9/13—Rev. A to Rev. B	
Changes to Figure 1	1
8/13—Rev. 0 to Rev. A	
Changes to Title.....	1
8/13—Revision 0: Initial Version	

(Continued from first page) Circuits from the Lab reference designs are intended only for use with Analog Devices products and are the intellectual property of Analog Devices or its licensors. While you may use the Circuits from the Lab reference designs in the design of your product, no other license is granted by implication or otherwise under any patents or other intellectual property by application or use of the Circuits from the Lab reference designs. Information furnished by Analog Devices is believed to be accurate and reliable. However, Circuits from the Lab reference designs are supplied "as is" and without warranties of any kind, express, implied, or statutory including, but not limited to, any implied warranty of merchantability, noninfringement or fitness for a particular purpose and no responsibility is assumed by Analog Devices for their use, nor for any infringements of patents or other rights of third parties that may result from their use. Analog Devices reserves the right to change any Circuits from the Lab reference designs at any time without notice but is under no obligation to do so.