

Panasonic

ENERGY SOLUTIONS

A Comprehensive Guide to Primary and Rechargeable Batteries



LITHIUM PRIMARY | LITHIUM ION | NICKEL METAL HYDRIDE

LITHIUM RECHARGEABLE | VRLA | ALKALINE

POWERED BY PANASONIC

ABOUT PANASONIC

Bringing strategic innovation and industrial technology expertise to our customers.

Many products sold by Fortune 500 companies are powered by Panasonic technology. We are proud to provide manufacturers with the performance, quality, and reliability that are synonymous with the Panasonic brand.

Panasonic began its existence by developing component and material technologies that still serve as the building blocks for the wide range of advanced products for which our company is best known today.

Panasonic is a leading supplier of batteries, offering advanced cell manufacturing and product technologies, superior quality, and one of the broadest lines of primary and rechargeable batteries in the industry.

Our batteries meet multiple market needs and are ideal for a variety of consumer, commercial and industrial portable power applications.

WHY CHOOSE PANASONIC BATTERIES?

- The largest and most extensive battery line in the industry
- Advanced cell manufacturing
- Superior quality
- Value added engineering support
- Our batteries meet multiple market needs and applications



Corporate Headquarters in Newark, New Jersey.

TABLE OF CONTENTS

LITHIUM ION	1
LITHIUM ION PIN	1
NICKEL METAL HYDRIDE	2
LITHIUM RECHARGEABLE COIN	3
LITHIUM PRIMARY CYLINDRICAL	8
VALVE REGULATED LEAD ACID	10
ALKALINE	12

Lithium Ion Batteries

High Energy Density, Safe Operation and Long-Life

Lithium Ion (Li-Ion) is a high energy density battery that is widely used in portable equipment. Lithium Ion uses lithium metallic oxide in its positive electrode (cathode) and carbon graphite material in its negative electrode (anode).

All Panasonic Lithium Ion batteries are covered by the Rechargeable Battery Recycling Corporation's (RBRC) recycling program.



FEATURES

- High energy density
- Higher voltage
- Light weight
- High power

APPLICATIONS

- Power tools
- Portable devices
- Medical equipment
- Automotive
- Energy storage



CYLINDRICAL TYPE							
Model Number	Nominal Voltage (v)	Typical Capacity (mAh)	Minimum Capacity (mAh)	Charge Voltage (v)	Dimensions		Weight (g)
					Diameter (mm)	Height (mm)	
UR18650A	3.60V	2250 mAh	2150 mAh	4.2	18.50 mm	65.10 mm	44.00g
UR18650RX (20A)*	3.60V	2050 mAh	1950 mAh	4.2	18.50 mm	65.30 mm	46.20g
UR18650ZTA	3.70V	3000 mAh	2900 mAh	4.35	18.60 mm	65.30 mm	49.00g
NCR18650BD	3.60V	3180 Mah	3030 mAh	4.2	18.25 mm	65.10 mm	49.50g
NCR18650BF	3.60V	3350 mAh	3250 mAh	4.2	18.24 mm	65.10 mm	46.50g
NCR18650PF	3.60V	2900 mAh	2750 mAh	4.2	18.15 mm	65.10 mm	47.00g

*Please contact Panasonic for availability

Pin Type Lithium Ion Battery

GENERAL DESCRIPTION

The industry's smallest cylindrical shaped rechargeable Lithium Ion battery which features high reliability and high output and is ideal for powering small devices such as wearable devices.

FEATURES

- High reliability
- High output
- Metallic can which prevents battery swelling
- Pin shaped, 3.65mm diameter lithium ion battery, industry's smallest

APPLICATIONS

- Wearable devices
- Electronic pens
- Hearing aids and measuring devices
- Near field communications (NFC)

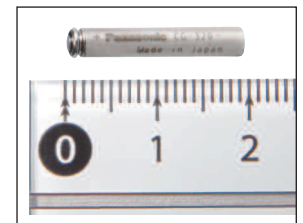

LITHIUM ION PIN						
Model Number	Nominal Voltage (V)	Typical Capacity (mAh)	Charge Voltage (V)	Dimensions (max)		Approx. Weight (g)
				Diameter (mm)	Height (mm)	
CG-320A	3.8	15	4.35	3.65 mm	20 mm	0.5
CG-425A	3.8	32	4.35	4.70 mm	25 mm	1.0
CG-435A	3.8	52	4.35	4.70 mm	35 mm	1.5

*CG-425A and CG-435A are still under development

Nickel Metal Hydride Batteries



GENERAL DESCRIPTION

Panasonic NiMH batteries are a robust rechargeable option that can tolerate harsh conditions while still outperforming other battery chemistries.

FEATURES

- Low Self Discharge | Batteries maintain capacity during idle periods
- Button Top Options | Replace standard AA and AAA primary batteries
- Temperature Tolerance | Outperforms Li Ion and VRLA batteries at extreme temperatures
- High Rate Discharge | Meets power tool requirements
- Long Life | Outperforms other rechargeable chemistries in backup applications



CYLINDRICAL TYPE

New Model Number	Old Model Number	Size	Nominal Voltage (V)	Minimum Capacity (mAh)	Average Capacity (mAh)	Diameter (with tube) (mm)	Height (with Tube) (mm)	Approx.Weight (g)
------------------	------------------	------	---------------------	------------------------	------------------------	---------------------------	-------------------------	-------------------

BUTTON TYPE TOP

BK80AAAB	N/A	AAA	1.2 V	750 mAh	780 mAh	10.5+0/-0.7	44.5+0/-1.0	13 g
BK200AAB	N/A	AA	1.2 V	1,900 mAh	2,000 mAh	14.5+0/-0.7	50.5+0/-1.0	29 g

STANDARD TYPE

BK65AAAK	N/A	AAA	1.2 V	650 mAh	700 mAh	10.5+0/-0.7	44.5+0/-1.5	12 g
BK70AAAJ	HHR70AAAJ	AAA	1.2 V	700 mAh	730 mAh	10.5+0/-0.7	44.5+0/-1.5	12 g
BK70AA	HHR70AA	AA	1.2 V	700 mAh	780 mAh	14.5+0/-0.7	49.0+0/-1.5	18 g
BK90AAA	HHR90AAA	AAA	1.2 V	830 mAh	880 mAh	10.5+0/-0.7	50.5+0/-1.5	14 g
BK120AA	HHR120AA	AA	1.2 V	1,150 mAh	1,220 mAh	14.5+0/-0.7	43.0+0/-1.5	23 g
BK150AA	HHR150AA	AA	1.2 V	1,500 mAh	1,580 mAh	14.5+0/-0.7	50.5+0/-1.5	26 g
BK200A	HHR200A	A	1.2 V	2,000 mAh	2,040 mAh	17.0+0/-0.7	43.0+0/-1.5	32 g
BK210A	HHR210A	A	1.2 V	2,100 mAh	2,200 mAh	17.0+0/-0.7	50.0+0/-2.0	38 g
BK380A	HHR380A	A	1.2 V	3,700 mAh	3,800 mAh	17.0+0/-0.7	67.0+0/-2.0	53 g
BK450A	HHR450A	A	1.2 V	4,200 mAh	4,500 mAh	18.2+0/-0.7	67.5+0/-1.5	60 g

HIGH TEMPERATURE & LONG LIFE TYPE

BK60AAAH	HHR60AAAH	AAA	1.2 V	500 mAh	550 mAh	10.5+0/-0.7	44.5+0/-1.5	13 g
BK70AAH	HHR70AAH	AA	1.2 V	700 mAh	750 mAh	14.5+0/-0.7	49.0+0/-1.5	18 g
BK160AH	N/A	A	1.2 V	1,600 mAh	1,720 mAh	17.0+0/-0.7	43.0+0/-1.5	29 g
BK210AH	HHR210AH	A	1.2 V	1,900 mAh	2,050 mAh	17.0+0/-0.7	50.0+0/-2.0	36 g
BK370AH	HHR370AH	A	1.2 V	3,500 mAh	3,700 mAh	18.2+0/-0.7	67.5+0/-1.5	60 g
BK1100FHU	N/A	F	1.2 V	11,000 mAh	12,000 mAh	33.0+0/-1.0	91.0+0/-2.5	250 g

HIGH RATE DISCHARGE & HIGH TEMPERATURE TYPE

BK250SCH	HHR250SCH	SC	1.2 V	2,500 mAh	2,650 mAh	23.0+0/-1.0	43.0+0/-1.5	55 g
BK310CH	N/A	C	1.2 V	3,100 mAh	3,300 mAh	25.8+0/-1.0	50.0+0/-2.0	80 g
BK330APH	HHR330APH	A	1.2 V	3,200 mAh	3,300 mAh	18.2+0/-0.7	67.5+0/-1.5	60 g

HIGH RATE DISCHARGE & RAPID CHARGE TYPE

BK200SCP	HHR200SCP	SC	1.2 V	1,900 mAh	2,100 mAh	23.0+0/-1.0	34.0+0/-1.5	42 g
BK260SCP	HHR260SCP	SC	1.2 V	2,450 mAh	2,700 mAh	23.0+0/-1.0	43.0+0/-1.5	55 g
BK300SCP	HHR300SCP	SC	1.2 V	2,800 mAh	3,050 mAh	23.0+0/-1.0	43.0+0/-1.5	57 g

LOW TEMPERATURE DISCHARGE TYPE

BK-10V1S	N/A	N/A	1.2	90000	95000	62.6+1.0/-1.0mm	188.7+1.0/-1.0mm	1,700 g
BK-10V10T	N/A	V	12	90000	95000	N/A	N/A	2,300 g

1. H Type: Improved low rate charge characteristics at higher temperatures. Ideal for back-up applications (with appropriate charge control circuitry).
 2. Mainly for low drain, extended run time applications.
 3. Mainly for high drain applications such as power tools.
 4. For reference only.
 5. After charging at 0.1It for 16 hours, discharging at 0.2It
- Note: /B=extended positive terminal (button top).

Lithium Rechargeable Coin Batteries

GENERAL DESCRIPTION

Panasonic Vanadium Pentoxide (VL Type) rechargeable lithium batteries are compact, high energy secondary batteries that have nearly twice the energy of conventional button-shaped Ni-Cd batteries.

FEATURES

- One high-voltage battery can serve your backup needs
- Can provide the voltage equivalent of two or three 1.2V Ni-Cd's or two capacitors
- Months of continuous use as a backup
- Self discharge rate less than 2% a year
- Superior reliability; withstands overcharging and discharging

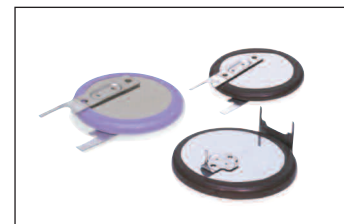

VANADIUM RECHARGEABLE LITHIUM BATTERIES (VL COIN CELLS)

Model Number	Electrical Characteristics 20°C (68°F)		Recommended Drain Standard (mA)	Dimensions (Max.)		
	Nominal Voltage (V)	*Nominal Capacity (mAh)		Diameter inch (mm)	Height inch (mm)	Weight oz. (g)
VL621	3.0	1.5	0.01	0.27(6.8)	0.08(2.1)	0.01(0.3)
VL1220	3.0	7.0	0.03	0.49(12.5)	0.08(2.0)	0.03(0.8)
VL2020	3.0	20.0	0.07	0.79(20.0)	0.08(2.0)	0.07(2.2)
VL2320	3.0	30.0	0.10	0.91(23.0)	0.08(2.0)	0.09(2.7)
VL2330	3.0	50.0	0.10	0.91(23.0)	0.12(3.0)	0.12(3.5)
VL3032	3.0	100.0	0.20	1.18(30.0)	0.13(3.2)	0.22(6.2)

APPLICATIONS

- Memory cards
- Personal computers
- Sequencers
- Telephones
- Tuners
- Video cameras
- Memory back-up in facsimiles

* Nominal capacity is based on a standard drain and cut off voltage down to 2.5V at 20°C (68°F).

GENERAL DESCRIPTION

These super compact lithium secondary batteries feature a new configuration in which a manganese compound oxide is used for the positive electrode, and a lithium/aluminum alloy for the electrode.

FEATURES

- Charge at voltage levels even under 3V
- Large capacity for hour-after-hour back-up
- Excellent withstand voltage, overcharge and overdischarge withstanding characteristics

MANGANESE RECHARGEABLE LITHIUM BATTERIES (ML COIN CELLS)

Model Number	Electrical Characteristics 20°C (68°F)		Recommended Drain Standard (mA)	Dimensions (Max.)		
	Nominal Voltage (V)	*Nominal Capacity (mAh)		Diameter inch (mm)	Height inch (mm)	Weight oz. (g)
ML421	3.0	2.3	0.005	0.19(4.8)	0.08(2.1)	0.004(0.11)
ML614 ¹	3.0	3.4	0.01	0.27(6.8)	0.06(1.4)	0.006(0.16)
ML621 ¹	3.0	5.0	0.01	0.27(6.8)	0.08(2.1)	0.008(0.23)
ML920	3.0	11.0	0.03	0.37(9.5)	0.08(2.0)	0.014(0.40)
ML1220	3.0	17.0	0.03	0.49(12.5)	0.08(2.0)	0.03(0.80)
ML2020	3.0	45.0	0.12	0.79(20.0)	0.08(2.0)	0.078(2.2)

APPLICATIONS

- Mobile telephones
- Memory cards
- Other small-size communications devices

* Nominal capacity shown is based on standard drain and cut off voltage down to 2.0V at 20°C (68°F)

¹Available as a bare cell.

Lithium Rechargeable Coin Batteries

COIN CELL TAB CONFIGURATIONS

Model Number	Tab Type		Configuration Type
	With Insulation Wrap	Without Insulation Wrap	
VL TYPE			
VL621		/DN	F
VL1220	/HFN		H
VL1220	/VCN		V
VL1220	/FCN		F
VL2020	/VCN		V
VL2020	/HFN		H
VL2320	/VCN		V
VL2320	/HFN		H
VL2320	/F2N		F
VL2330	/VCN		V
VL2330	/VCN		H
VL2330	/F3N		F
VL3032	/GUFN		G
VL3032	/F2N		F

Model Number	Tab Type		Configuration Type
	With Insulation Wrap	Without Insulation Wrap	
ML TYPE			
ML421	Contact Panasonic for details on available tab configurations.		
ML614 ¹		/FN	F
ML621 ¹		/DN	F
ML920		/DN	F
ML1220	/F1AN		F
ML1220	/V1AN		V
ML2020	/G1AN		G
ML2020	/H1CN		H
ML2020	/V1AN		V

¹Also available as a bare cell.
Please refer to the Panasonic website for exact tab dimensions.

Minimum order requirements may apply.
Please refer to the Panasonic website for exact tab dimensions.

TYPICAL TAB CONFIGURATIONS

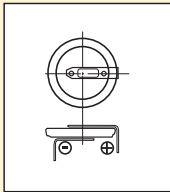

H Type

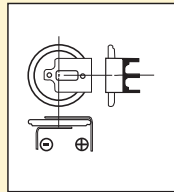

G Type

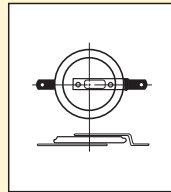

F Type

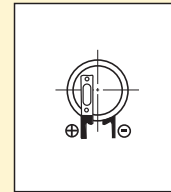

V Type

Lithium Primary Coin Batteries

GENERAL DESCRIPTION

Panasonic coin type lithium batteries are high energy, high reliability batteries for a variety of applications. The full 3 volts in these high energy batteries is about twice that of conventional dry batteries. Panasonic coin type lithium batteries are available in two types: poly-carbonmonofluoride lithium batteries (BR Series) for users requiring extended reliability and safety, and manganese dioxide lithium batteries (CR Series) for users requiring high voltage and strong load pulse characteristics.

FEATURES

- High voltage of 3 volts — twice that of conventional batteries
- Extremely low self-discharge for long service and shelf life
- Compact and lightweight, with extremely high energy density per unit weight
- Extremely safe (poly-carbon monofluoride lithium batteries)
- Extremely strong load pulse characteristics (manganese dioxide lithium)

APPLICATIONS

- Remote Keyless Entry
- Tire Pressure Monitor Sensors
- IoT Devices
- Security Systems
- Drug Delivery Devices
- iBeacons

Operating Temperature CR Type: -30°C ~ 60°C
 Operating Temperature BR Type: -30°C ~ 80°C

COIN TYPE



POLY-CARBONMONOFLUORIDE (BR COIN)

Model Number	Electrical Characteristics (20°C)		Recommended Drain Continuous (mA)	Dimensions (Max.)		
	Nominal Voltage (V)	Nominal Capacity (mAh)		Diameter (mm)	Height (mm)	Weight (g)
BR1220	3	35	0.03	12.5	2.00	0.7
BR1225	3	48	0.03	12.5	2.50	0.8
BR1632	3	120	0.03	16.0	3.20	1.5
BR2032	3	190	0.03	20.0	3.20	2.5
BR2325	3	165	0.03	23.0	2.50	3.2
BR2330	3	255	0.03	23.0	3.00	3.2
BR3032	3	500	0.03	30.0	3.20	5.5

*Nominal capacity shown is based on standard drain

BR COIN CELL TAB CONFIGURATIONS

Model Number	Tab Type		Configuration Type	Model Number	Tab Type		Configuration Type
	With Insulation Wrap	Without Insulation Wrap			With Insulation Wrap	Without Insulation Wrap	
BR1220	/HFN		H	BR2325	/HCN	/HBN	H
BR1220	/VCN		V	BR2325	/VCN		V
BR1225	/HCN	/HBN	H	BR2325		/HGN	H
BR1225	/VCN		V	BR2325	/2HCN		H
BR1632	/HFN		H	BR2325		/VGN	V
BR2032		/HGN	G	BR2330	/HFN	/HEN	G
BR2032	/GUFN	/GUN	G	BR2330	/GUFN	/GUN	G
BR2032	/HFN	/HEN	H	BR2330	/VCN	/VBN	V
BR2032		/VBN	V	BR2330	/GVFN	/GVN	V
BR2032	/GVFN	/GVN	V	BR2330	/F3N		F
BR2032	/F2N		F	BR3032	/VCN		V
				BR3032	/F2N		F

Lithium Primary Coin Batteries

MANGANESE DIOXIDE (CR COIN)

Model Number	Electrical Characteristics (20°C)		Recommended Drain Continuous (mA)	Dimensions (Max.)		
	Nominal Voltage (V)	Nominal Capacity (mAh)		Diameter (mm)	Height (mm)	Weight (g)
CR1025	3	30	0.10	10.0	2.5	0.7
CR1216	3	25	0.10	12.5	1.6	0.7
CR1220	3	35	0.10	12.5	2.0	1.2
CR1612	3	40	0.10	16.0	1.2	0.8
CR1616	3	55	0.10	16.0	1.6	1.2
CR1620	3	75	0.10	16.0	2.0	1.3
CR1632	3	140	0.10	16.0	3.2	1.8
CR2012	3	55	0.10	20.0	1.2	1.4
CR2016	3	90	0.10	20.0	1.6	1.6
CR2025	3	165	0.20	20.0	2.5	2.3
CR2032	3	225	0.20	20.0	3.2	2.9
CR2330	3	265	0.20	23.0	3.0	3.8
CR2354	3	560	0.20	23.0	5.4	5.8
CR2412	3	100	0.20	24.5	1.2	2.0
CR2450	3	620	0.20	24.5	5.0	6.3
CR2477	3	1000	0.20	24.5	7.7	10.5
CR3032	3	500	0.20	30.0	3.2	10.5

*Nominal capacity shown is based on standard drain

CR COIN CELL TAB CONFIGURATIONS

Model Number	Tab Type		Configuration Type	Model Number	Tab Type		Configuration Type
	With Insulation Wrap	Without Insulation Wrap			With Insulation Wrap	Without Insulation Wrap	
CR1220	/HFN		H	CR2330	/GUFN	/GUN	G
CR1220	/VCN		V	CR2330	/HFN		H
CR1616		/F2N	F	CR2330	/GVFN	/GVN	V
CR1632	/HFN		H	CR2330	/F3N		F
CR2016	/F2N		F	CR2354	/HFN	/HEN	H
CR2032		/HU3N	H	CR2354	/GUFN	/GUN	G
CR2032		/HG N	G	CR2354	/VCN		V
CR2032	/HSN		H	CR2450	/H1AN		H
CR2032	/GUFN	/GUN	G	CR2450		/G1AN	G
CR2032	/HFN	/HEN	H	CR2477	/VCN		V
CR2032		/VBN	V	CR2477	/HFN		H
CR2032	/GVFN	/GVN	V	CR3032	/VCN		V
CR2032	/F4N		F	CR3032	/F2N		F
CR2032	/F2N		F				

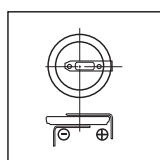

H Type

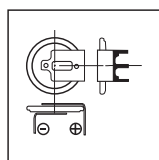

G Type

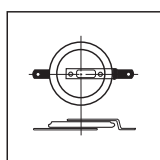

F Type

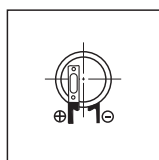

V Type

GENERAL DESCRIPTION

High Temperature Manganese Dioxide Cells

APPLICATIONS

- Automotive
- TPMS

MANGANESE DIOXIDE (CR COIN) HIGH TEMPERATURE

Model Number	Electrical Characteristics			Operating Temp. Range (°C)	Dimensions		Approximate Weight (g)
	Nominal Voltage (v)	Nominal Capacity (mAh)	Standard Continuous Drain (mA)		Diameter (mm)	Height (mm)	
CR-2450A	3.0	560	0.2	-40 to +105	24.5	5.0	6.3

Lithium Primary Coin Batteries

HIGH OPERATING TEMPERATURE POLY-CARBONMONOFLUORIDE LITHIUM BATTERIES (BR "A" SERIES)

GENERAL DESCRIPTION

Panasonic's coin type high temperature batteries are high energy, high reliability batteries for applications that require a wider operating temperature range. The full 3 volts in these high energy batteries is about twice that of conventional dry batteries.

FEATURES

- Wide operational temperature range
- Good storage stability
- Constant operating voltage
- Available with Tab terminals for PCB mounting

APPLICATIONS

- Automotive electronic systems
- Tollway transponders
- RFID



POLY-CARBONMONOFLUORIDE (BR "A" COIN)"

Model Number	Nominal Voltage (V)	Nominal Capacity (mAh)	Dimensions (max)		Weight (g)	Temp. Range °C
			Diameter (mm)	Height (mm)		
BR1225A	3	48	12.5	2.5	00.8	-40° C~125° C
BR1632A	3	120	16.0	3.2	1.5	-40° C~125° C
BR2330A	3	165	23.0	3.0	3.2	-40° C~125° C
BR2450A ¹	3	550	24.5	5.0	5.0	-40° C~125° C
BR2477A	3	1000	24.5	7.7	8.0	-40° C~125° C

HIGH TEMPERATURE BR COIN CELL TAB CONFIGURATIONS

See page 5 for diagrams

Model Number	Tab Type		Configuration Type
	With Insulation Wrap	Without Insulation Wrap	
BR1225A	/FAN		F
BR1225A	/HBN	/HAN	H
BR1632A	/FAN		F
BR1632A		/GAN	G
BR1632A	/HAN	/HBN	H
BR1632A	/VAN		V
BR2330A	/FAN		F
BR2330A		/GAN	G
BR2330A	/HDN		H
BR2330A	/VAN		V
BR2450A ¹	/FAN		F
BR2450A ¹	/GAN		G
BR2477A	/FBN		F
BR2477A	/GAN		G
BR2477A	/HBN	/HCN	H
BR2477A	/VAN		V

Please refer to the Panasonic website for exact tab dimensions.

Lithium Primary Cylindrical Batteries



GENERAL DESCRIPTION

Panasonic cylindrical lithium batteries are known for their high voltage, energy density, durability, and stable operation.

FEATURES

- High energy density
- Long shelf life
- Stable operation
- High rate discharge
- Strong leakage resistance
- Excellent durability

APPLICATIONS

- Memory back-up
- Utility meters
- Emergency signal light
- Electric locks
- Electronic measurement equipment

POLY-CARBONMONOFLUORIDE (BR SERIES) LITHIUM BATTERIES

Model Number	Electrical Characteristics			Dimensions		Approximate Weight (g)	Operating Temperature (°C)
	Nominal Voltage (V)	**Nominal Capacity (mAh)	Standard Drain (mA)	Diameter (mm)	Height (mm)		
BR-1/2AA	3	1,000	2.5	14.5	25.5	8.0	- 40 to +100
BR-2/3A	3	1,200	2.5	17.0	33.5	13.5	- 40 to +85
BR-2/3AG*	3	1,450	2.5	17.0	33.5	13.5	- 40 to +85
BR-A	3	1,800	2.5	17.0	45.5	18.0	- 40 to +85
BR-AG*	3	2,200	2.5	17.0	45.5	18.0	- 40 to +85
BR-C	3	5,000	5.0	26.0	50.0	42.0	- 40 to +85

Note: * G Versions are higher capacity. ** Nominal capacity is based on standard drain & cutoff voltage down to 2.0V at 20 degrees C..

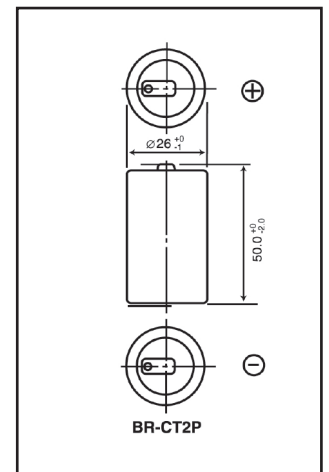
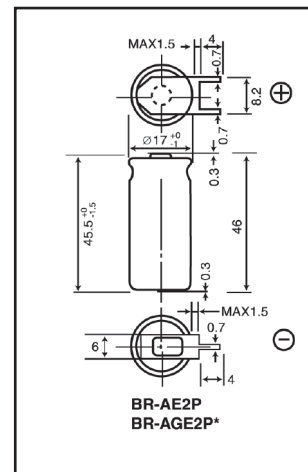
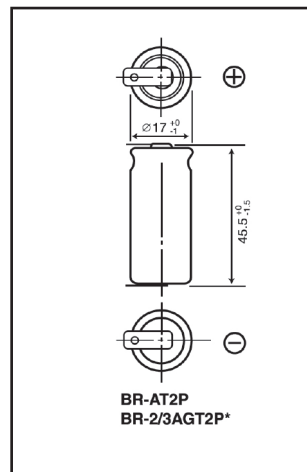
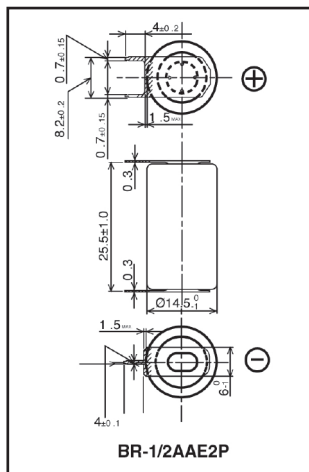
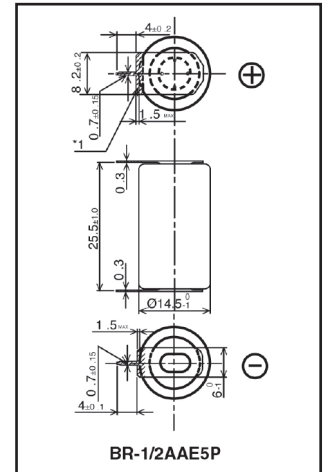
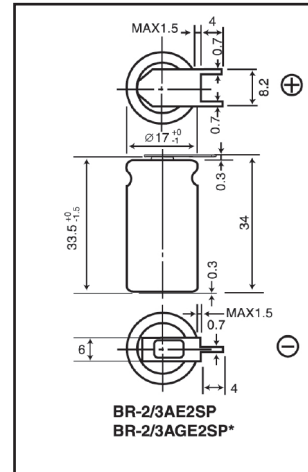
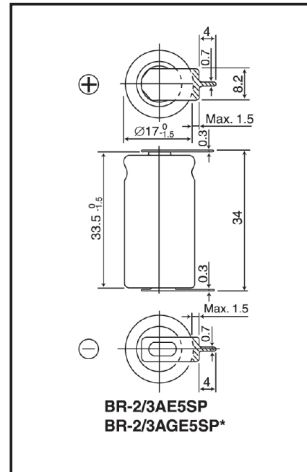
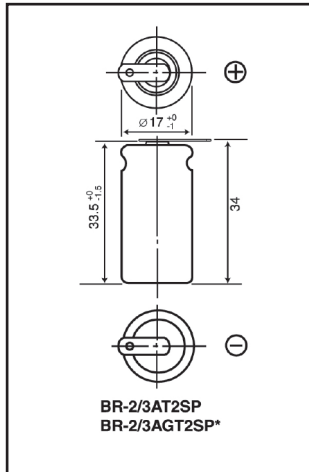

Lithium Primary Cylindrical Batteries



GENERAL DESCRIPTION

Ideal for designs requiring batteries with retail availability to allow for convenient end user replacement

FEATURES

- High Discharge current pulse capability
- Built in Safety Features
- Superior Shelf Life / Minimal Self-Discharge
- Operating Temperature (-40°C to 70°C)
- High Energy Density

APPLICATIONS

- Cameras
- Memory back-up over a wide range of applications
- Flashlights
- Medical Apps.
- Remote Monitoring Systems
- Other applications where ease of replacement is required

USER REPLACEABLE MANGANESE DIOXIDE (CR SERIES) LITHIUM BATTERIES

Model Number	Voltage (V)	Nominal Capacity (mAh)	Dimensions (mm)	Height (mm)	Weight (g)
CR123A	3	1,550*	17.0	34.5	17
CR2	3	850*	15.6	27.0	11

* Based on standard drain and cut off voltage down to 2.0 V at 20°C

** Based on standard drain and cut off voltage down to 4.0 V at 20°C



GENERAL DESCRIPTION

The Industrial CR Series features superior high-rate and long life performance. Internal resistance remains low during long term discharge providing consistent high rate pulse performance throughout its entire life. "Wake-up-pulse discharge" is not required for high current pulse discharge as in other batteries.

FEATURES

- Superior long term reliability
- High current pulse discharge capability
- Operating temperature (-40 -70)
- High safety and energy density

APPLICATIONS

- Meter, AMR (Automatic Meter Reading)
- Fire alarm (smoke detector)
- Home security device
- ETC (Electric Toll Collection)

INDUSTRIAL MANGANESE DIOXIDE (CR SERIES) LITHIUM BATTERIES

Model Number	Voltage (V)	Nominal Capacity (mAh)	Dimensions (mm)	Height (mm)	Weight (g)
CR-2/3AZ	3	1600	17.0	33.5	17
CR-2Z	3	1000	15.6	27.0	11
CR-AG	3	2400	17.0	45.5	17

GENERAL DESCRIPTION

Panasonic carbon monofluoride pin type lithium batteries are slim and lightweight through the use of an aluminum case. This unique design, developed first by Panasonic, combines the best of battery technologies.

FEATURES

- Compact and lightweight
- 2x the voltage of conventional dry batteries
- Operating temperature (-30°C~+60°C)
- Pin terminal for easy connection

APPLICATIONS

- Fishing pole tip lights
- LED illumination
- LED night fishing floats
- Microphones

POLY-CARBONMONOFLUORIDE (BR PIN) LITHIUM BATTERIES

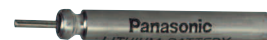

Model Number	Electrical Characteristics				Dimensions		Weight (g)
	Nominal Voltage	Nominal Capacity (mAh)	Recommended Drain		Diameter (mm)	Height (mm)	
			Pulse (mA)	Standard (mA)			
BR425	3	25	4	0.5	4.2	25.9	0.55
BR435	3	50	6	1.0	4.2	35.9	0.85

Valve Regulated Lead Acid Batteries*



GENERAL DESCRIPTION

Panasonic's tough Valve Regulated Lead Acid rechargeable batteries are designed to provide outstanding performance in withstanding over-charge, over-discharge, and resisting vibration and shock. Compact, these batteries save installation space, while providing full and reliable power. The use of special sealing epoxies, tongue and groove case and cover construction, and long-sealing paths for posts and connectors, assures that the Valve Regulated Lead Acid battery will offer exceptional leak resistance, and allows them to be used in any position. Panasonic Valve Regulated Lead Acid batteries (weighing less than 2 lbs) are covered by the Rechargeable Battery Recycling Corporation's (RBRC) recycling program. For larger batteries, call 1-800-SAV-LEAD.

FEATURES

- State-of-the-art Absorbed Glass Mat (AGM) technology
- Superior design and low voltage spread gives excellent performance
- Enhanced lifespan due to low and stable charge current
- 100% inspection after final assembly and before shipment
- High quality and reliability
- Selected batteries with flame retardant battery containers according to UL94 V-0
- High power density
- Long service life
- Maintenance free operation

APPLICATIONS

- Electric lawn mowers
- Medical equipment
- Emergency Lighting
- UPS systems
- Alarm systems
- Wind turbines
- Vending machines
- Mobile floor sweepers
- Solar or wind powered street lighting and advertising displays etc.
- Wheelchairs
- Energy storage



*Previously referred to as "Sealed Lead Acid" batteries.

BACK-UP AND MAIN POWER SUPPLIES (CYCLE AND TRICKLE USE)

Model Number*	Nominal Voltage (V)	Rated capacity 20 hours rate (Ah)	Outline dimensions inch (mm)				Wt. (Approx.) lbs (kg)	Terminal Types	Battery-case resin	
			Length	Width	Height	Total height			UL94HB	UL94V-0
LC-R061R3P	6	1.3	3.82 (97)	0.95 (24)	1.97 (50)	2.17 (55)	0.66 (0.30)	B	○	
LC-R063R4P	6	3.4	5.28 (134)	1.34 (34)	2.36 (60)	2.6 (66)	1.37 (0.62)	B	○	
LC-R064R5P	6	4.5	2.76 (70)	1.89 (48)	4.02 (102)	4.26 (108)	1.72 (0.78)	B	○	
LC-R067R2P(a)	6	7.2	5.95 (151)	1.34 (34)	3.70 (94)	3.94 (100)	2.78 (1.26)	B/C	○	
LC-R0612P(a)	6	12.0	5.95 (151)	1.97 (50)	3.70 (94)	3.94 (100)	4.30 (1.95)	B/C	○	
LC-R121R3P	12	1.3	3.82 (97)	1.87 (48)	1.97 (50)	2.17 (55)	1.30 (0.59)	B	○	
LC-R122R2P	12	2.2	6.97 (177)	1.34 (34)	2.36 (60)	2.6 (66)	1.76 (0.80)	B	○	
LC-R123R4P	12	3.4	5.28 (134)	2.64 (67)	2.36 (60)	2.6 (66)	2.65 (1.20)	B	○	
LC-R127R2P(a)	12	7.2	5.95 (151)	2.54 (64.5)	3.70 (94)	3.94 (100)	5.45 (2.47)	B/C	○	
LC-RA1212P(a)	12	12.0	5.95 (151)	3.86 (98)	3.70 (94)	3.94 (100)	8.36 (3.80)	B/C	○	
LC-RA1215P(a)	12	15.0	5.95 (151)	3.86 (98)	3.70 (94)	3.94 (100)	9.13 (4.15)	B/C	○	
LC-RD1217P	12	17.0	7.13 (181)	2.99 (76)	6.58 (167)	6.58 (167)	14.34 (6.50)	D	○	
LC-R1233P	12	33.0	7.70 (195.6)	5.12 (130)	6.10 (155)	7.09 (180)	26.50 (12.0)	E	○	●

* Previous model number is given in parentheses

(a) Add applicable codes for terminal type: P = faston 187, P1 = faston 250

Note: Battery cases marked with a (○) are the normal product using the standard resin.

Those marked with a solid circle (●) indicate specifications as per special order.

Valve Regulated Lead Acid Batteries

MAIN POWER SUPPLIES (CYCLE USE)

Model Number	Nominal Voltage (V)	Rated capacity 20 hours rate (Ah)	Outline dimensions inch (mm)				Wt. (Approx.) lbs (kg)	Terminal Types	Battery-case resin	
			Length	Width	Height	Total height			UL94HB	UL94V-0
LC-XC1228AP	12	28.0	6.50 (165)	4.92 (125)	6.89 (175)	7.07 (179.5)	24.34 (11)	G	○	

Note: Battery cases marked with a (○) are the normal product using the standard resin. Those marked with a solid circle (●) indicate specifications as per special order.

BACK-UP POWER SUPPLIES (LONG LIFE TRICKLE USE*)

Model Number	Nominal Voltage (V)	Rated capacity 20 hours rate (Ah)	Outline dimensions inch (mm)				Wt. (Approx.) lbs (kg)	Terminal Types	Battery-case resin	
			Length	Width	Height	Total height			UL94HB	UL94V-0
LC-P067R2P(a)	6	7.2	5.95 (151)	1.34 (34)	3.70 (94)	3.94 (100)	2.87 (1.3)	B/C		
LC-P0612P(a)	6	12.0	5.95 (151)	1.97 (50)	3.70 (94)	3.94 (100)	4.41 (2.0)	B/C		
LC-P127R2P(a)	12	7.2	5.95 (151)	2.54 (64.5)	3.70 (94)	3.94 (100)	5.52 (2.5)	B/C		○
LC-PD1217P	12	17.0	7.13 (181)	2.99 (76)	6.58 (167)	6.58 (167)	14.34 (6.5)	D	●	
LC-P1220P	12	20.0	7.13 (181)	2.99 (76)	6.58 (167)	6.58 (167)	14.6 (6.6)	D	○	
LC-P1220AP	12	20.0	7.13 (181)	2.99 (76)	6.58 (167)	6.58 (167)	14.6 (6.6)	G	●	
LC-P1228P	12	28.0	6.50 (165)	4.92 (125)	6.89 (175)	7.07 (179.5)	24.3 (11)	D	○	
LC-P1228AP	12	28.0	6.50 (165)	4.92 (125)	6.89 (175)	6.89 (175)	24.3 (11)	G	○	●

(a) Add applicable codes for terminal type: P = faston 187, P1 = faston 250, P2 = 187/250

Note: Battery cases marked with an ○ are the normal product using the standard resin.

Those marked with a solid circle ● indicate specifications as per special order.

*Expected trickle life approximately 6 years

BACK-UP POWER (HIGH POWER SERIES)

Model Number	Nominal Voltage (V)	Rated capacity Watts/Cell at 10 Minute Rate	Outline dimensions inch (mm)				Wt. (Approx.) lbs (kg)	Terminal Types	Battery-case resin	
			Length	Width	Height	Total height			UL94HB	UL94V-0
UP-VW1220P1	12	20	5.51 (140)	1.52 (38.5)	3.70 (94)	4.00 (101.5)	2.98 (1.35)	C	○	●
UP-VW1245P1	12	45	5.95 (151)	2.54 (64.5)	3.70 (94)	4.00 (101.5)	5.74 (2.6)	C	○	
UP-VW1228P1	12	28	5.95 (151)	2.54 (64.5)	3.70 (94)	4.00 (101.5)	4.07 (1.85)	C		
UP-VW1236P1	12	36	5.95 (151)	2.54 (64.5)	3.70 (94)	4.00 (101.5)	4.51 (2.05)	C		

TERMINAL TYPES:

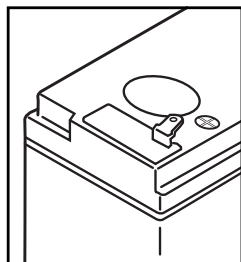

(B) Faston type 187
(C) Faston type 250

Indicated by model # suffix:
P=187
P1=250
P2=250(+)/187(-)

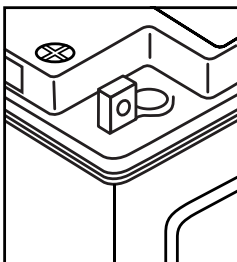

(D) M5 bolt and nut type
(E) M6 bolt and nut type

Indicated by model # suffix: P

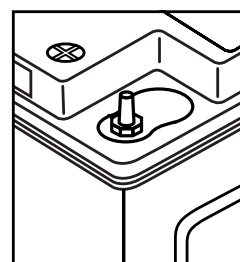

(G) M5 threaded post type
(H) M6 threaded post type

Indicated by model # suffix: AP

Alkaline Batteries

GENERAL DESCRIPTION

Long lasting. Designed to support industrial applications.

Panasonic's alkaline batteries are designed with a power density that enables them to last longer while still supporting industrial strength applications. Standardized with high-current and large capacity, the Alkaline series provides customers with high performance results.

FEATURES

- Heavy current and continuous drain
- Operates reliably in wide temperature ranges
- EU compliant dustbin
- Easier cross-referencing with IEC battery codes



INDUSTRIAL ALKALINE BATTERIES

Model Number	Size	V	Diameter (mm)	Height (mm)	Avg. Wt. (g)
LR20XWA	D	1.5	33.3	60.5	141.0
LR14XWA	C	1.5	25.5	49.5	70.0
LR6XWA	AA	1.5	14.50	50.0	23.0
LR03XWA	AAA	1.5	10.20	44.10	11.0

Also available in contractor boxes.

Model Number	V	L Inch (mm)	W (mm)	D (mm)	Avg. Wt. (g)
6LF22XWA (9V)	9	1.0 (47.5)	25.50	17.50	45

Also available in contractor boxes.

APPLICATIONS

- Toys and cordless products
- Security
- Medical devices
- Flashlights
- Electric shavers
- HVAC systems

Panasonic

For more information on how Panasonic can assist you with your battery power solution needs contact us.

Call | 1-877-PANABAT (877-726-2228)

Email | Oembatteries@us.Panasonic.com

New Website | <https://na.industrial.panasonic.com/products/batteries>

New Blog | <http://na.industrial.panasonic.com/blog>

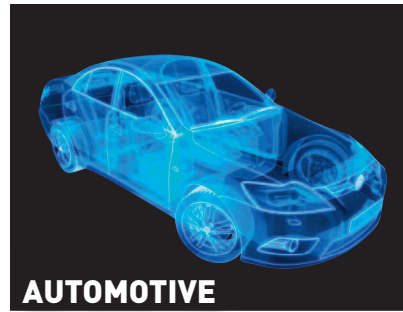

PANASONIC BATTERIES

1701 GOLF ROAD | TOWER 3 | ROLLING MEADOWS | ILLINOIS 60008

Copyright©2018 Panasonic Corporation of North America | All Rights Reserved

POWERED BY PANASONIC