

# An Overview of Motion Processing Solutions for Consumer Products

By Doug Vargha and Michael Maia

## Making Movement Digital

The integration of accelerometers and gyroscopes has successfully reached a point where consumer devices can readily incorporate motion while beginning to meet cost, size, robustness, and battery life targets. As consumer electronics companies continually search for the next differentiating product functionality, they are increasingly adopting motion in gaming, mobile handset, digital still camera, TV remote control, medical, and sports and fitness equipment devices in order to stand apart from competitors.

There are a host of sensors generated by advancements in MEMS technologies that make this revolutionary adoption of motion possible, and they all perform their own unique complementary functions. These devices include inertial sensors such as gyroscopes and accelerometers, compass sensors, cameras, and GPS receivers. Motion processing solutions typically include a combination of sensors to achieve optimal performance by using more than one type of sensing element.

This paper discusses the usage of common sensor types and how sensors can be effectively combined in a complementary fashion. It introduces the state-of-the-art InvenSense™ *MotionProcessing™* technology through the integration of gyros from InvenSense and a reference design that enables developers to create advanced electronic devices incorporating with up to nine axes of motion.

## Market Need for Motion Processing Solutions

Motion is already becoming a “must have” function in devices such as console games, as demonstrated in the Nintendo Wii and Sony PlayStation 3 controller where motion is used to control game play; and in cell phones where motion processing is used for display orientation, for gaming and for user interface functionality.

Such motion-processing functionality is finding its way into all types of electronic devices. For example, portable medical devices are being developed for patient monitoring and rehabilitation for remote

medicine; digital cameras are incorporating position and heading sensors to augment the visual information by showing both where the shot was taken (geo-tagging) and at what direction the camera was facing; remote controls are incorporating motion processing solutions to provide menu navigation and increased access to the web and other content on today’s connected digital TVs; and sports equipment is incorporating motion to track users’ motion for training and social purposes. As motion processing technologies become smaller, more affordable and more power efficient, the applications are virtually limitless.

## Motion-Based Sensor Overview

In order to design a motion processing solution, an understanding of various motion sensors and their fundamentals are required.

### Accelerometers

Accelerometers are used to sense linear acceleration and tilt angle. Acceleration can take one of two forms:

1. Acceleration due to gravity
2. Acceleration due to translation (movement)

Figure 1 shows the fundamentals of an accelerometer. In a typical implementation, a suspended proof mass reacts to acceleration in its axis of orientation by moving. This movement changes the capacitance between the mass and its sense electronics, and this capacitance is converted to an output voltage. An analog-to-digital converter then digitizes this voltage for further use by a microcontroller (MCU).

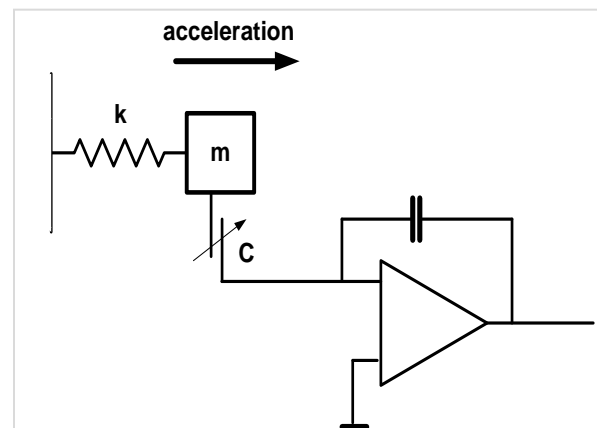
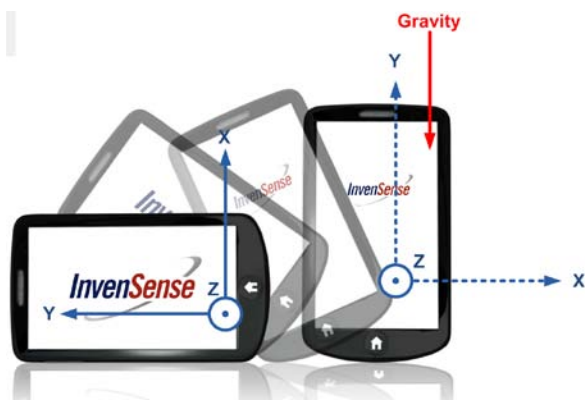

**Figure 1. Accelerometer Basics.** Linear acceleration causes mass *m* to move, varying capacitance *C*, which is changed into a voltage by the sensor electronics. This voltage is then digitized and used by the system processor.

Current accelerometers typically incorporate three axes for sensing motion on the X, Y, and Z axes, and include ADCs ranging from 6- to 14-bits. For consumer devices, full-scale ranges are typically from  $\pm 1g$  to  $\pm 8g$ , and supply current ranges from around  $10\mu A$  in low-power wake-up mode (at  $\sim 10Hz$  update rate) to up to  $400\mu A$  in full-power mode (at  $\sim 200Hz$  update rate). Due to their low supply current, accelerometers often are used to “wake up” a device when motion is detected. There are more than a dozen manufacturers of these devices. The current state-of-the-art devices include the following: STMicroelectronics® LIS331, Kionix® KXTF9, Bosch® BMA180, Analog Devices® ADXL346, and Freescale® MMA8450Q. Accelerometers commonly find usage as tilt and motion sensors for gaming and portrait or landscape display orientation recognition in cell phones and other portable computing devices, and as step detectors in pedometers.

#### Limitations of Accelerometers

Since accelerometers cannot distinguish between acceleration due to movement or due to gravity, their outputs need to be filtered when being used as a tilt sensor. However, filtering makes for a sluggish response. This is why gyros are often used in combination with accelerometers to provide more accurate and responsive motion-based sensing. For example, to achieve a responsive one-for-one gaming experience, Nintendo supplemented the accelerometers in its Wii Remote with gyroscopes in its Wii Motion Plus dongle.



**Figure 2. Accelerometers can be used to detect portrait and landscape orientation. As the handset moves from the portrait to the landscape orientation, the gravity vector changes from pointing in the -Y direction to pointing in the -X direction.**

Another limitation with accelerometers is in sensing portrait and landscape orientations. When the axes of the device display aligns with the gravity vector,

portrait/landscape orientation using accelerometers works well (Figure 2). However, when the axes of the display are perpendicular to the gravity vector, gravity is not useful for portrait/landscape orientation and another sensor such a gyro must be used for automatic display adjustment (Figure 3).

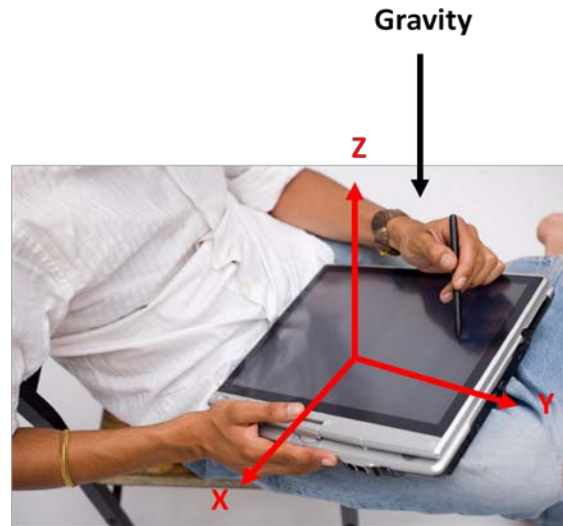

**Figure 3. Using an accelerometer, automatic switching between portrait and landscape modes does not work when a device is held horizontally, since the gravity vector is approximately zero for both the X and Y axes. Thus another sensor, such as a gyro is needed to sense orientation changes.**

#### Gyroscopes

Rate gyroscopes (gyros) are used to sense the angular rate of velocity (rotation). Figure 4 shows the fundamentals of a rate gyroscope, which operates on the principle of the Coriolis effect where a moving mass with velocity  $v$ , rotating at a rate  $\Omega$ , will be subject to an acceleration  $a_{cor}$  that is proportional to the rate of acceleration. This Coriolis acceleration causes the plates of a sense capacitor to move, varying its capacitance. This capacitance is converted into a voltage and is digitized with an analog-to-digital converter for use by a system microprocessor.

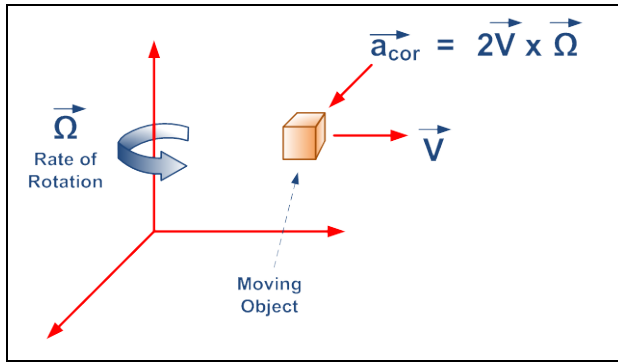

**Figure 4. Rate Gyroscope Basics.**

The Coriolis effect states that a moving mass with velocity  $v$ , rotating at a rate  $\Omega$ , will be subject to an acceleration  $a_{cor}$ . This causes mass  $m$  to move, varying capacitance  $C$ , which is changed into a voltage by the sensor electronics. This voltage is then digitized and used by the system processor.

The current state-of-the-art for consumer motion processing gyros is the InvenSense ITG-3200™ 3-axis digital gyroscope (Figure 5). This is the world's first integrated gyro with three axes of rotation (pitch, roll, yaw) on a single silicon chip. Until now, meeting the large market opportunity for motion-based gaming and television 3D remote control menu navigation has been held up because of a lack of affordable gyros and because of total solution costs. The ITG-3200 uniquely addresses these market needs through innovative system integration and a digital output design that also reduces power consumption by over 60% and comes in package size 50% smaller than competing analog solutions.

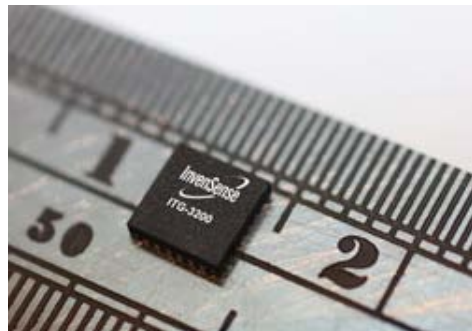

**Figure 5. The ITG-3200 3-axis digital gyroscope is a state-of-the-art gyro from InvenSense. It contains a triple (X, Y, and Z-axes) MEMS rate gyroscope, with triple 16-bit ADCs in a small 4x4x0.9mm QFN package.**

Unlike accelerometers, gyroscopes are not affected by gravity, but react solely to rotational motion. As such, they can be used in a complementary fashion with accelerometers to help decompose motion vectors

into their separate components of gravity, linear motion, and rotational motion, all while doing so in a responsive, low-latency fashion. As an example,

Figure 6a shows the output of an accelerometer as a portable electronic device is moved from portrait to landscape orientation and back again. As the device rotates, the gravity vector makes the transition from X to Y and back again. However, an inspection of the figure shows that in addition to the desired outputs (portrait and landscape horizontal vectors with a ramp between them) there are also signal peaks as the motion starts and stops and also noise where the device is relatively still. The portrait and landscape (relatively) horizontal signals are caused by the gravity vector and the peaks are caused by the motion sensor's response to the acceleration caused by changing the phone's velocity as the phone starts and stops moving. These additional, undesired signals are caused by translational motion and could be filtered out using a simple low-pass filter. However, while this would effectively remove the peaks, it would lead to an output that is not responsive, as an artifact of the low-pass filter is a delayed output.

Figure 6b shows an output that is achieved when combining a gyroscope output with the accelerometer data. Through a mathematical process called sensor fusion, the tilt angle of the phone can be obtained in a responsive fashion without the artifacts present when using an accelerometer alone.

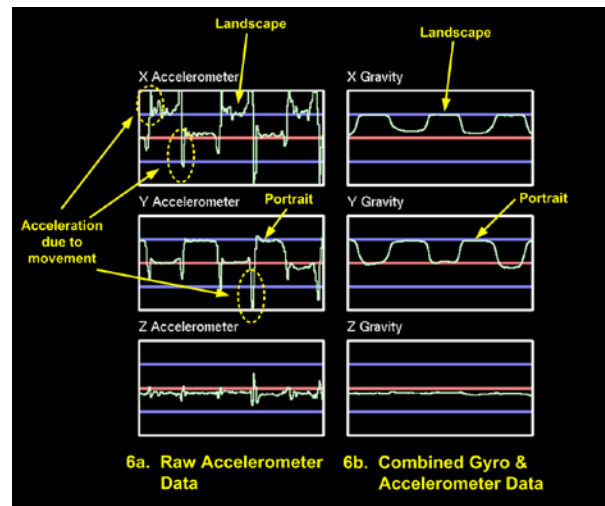

**Figure 6a & 6b. 6a: Accelerometer output when switching from portrait to landscape modes. Spikes at the beginning and end of rotation are due to acceleration due to movement. 6b: With the addition of a gyroscope, an output that is both responsive and free of noise is obtained.**

### *Limitations of Gyroscopes*

The output of rate gyroscopes is rotational rate, and to obtain a relative change in angle, one performs a single integration on the gyro outputs. Thus error in gyro bias (the output of the gyro when rotation is zero) leads to an error that increases with integration time. Consequently, methods must be taken to compensate for these bias errors, which are caused by drift due to time and temperature, and by noise.

### *Bias Compensation of Gyroscopes*

Common methods of compensation involve the use of other sensors, such as accelerometers for tilt angle, and compasses for heading. Alternately, changes in bias may be sensed when the device is not moving (i.e. is set down on a table). No motion is detected by looking at peak deviation in gyro output during a relatively short timeframe, such as two seconds. If the peak-to-peak signal is below a predetermined threshold, it is determined that the device is stationary, and the average gyro output during that time becomes the new bias setting.

### *Bias in Other Sensors*

Note that accelerometers and compass sensors also have bias drift, but since accelerometers provide tilt angle directly (without integration) by measuring gravity, and since compass sensors provide heading directly by measuring the earth's magnetic field, bias errors in these sensors are not integrated when providing tilt angle or heading. However, when double integrating the output of an accelerometer to provide distance or when single integrating its output to provide rate, the bias errors of the accelerometer become important. In general, only when a sensor's output does not require integration do bias errors become less important.

### ***Magnetic Compass Sensors***

Magnetic sensors (also known as compass sensors) are used to determine heading (yaw orientation) using magnetic north as a reference. There are various technologies employed to make compass sensors, including Hall, anisotropic magnetoresistive (AMR), and giant magnetoresistive (GMR). These devices share the common trait that some physical property will change in the presence of a magnetic field, and it is this change that allows for the electronic measurement of magnetic fields.

The value of compass sensors is that they provide absolute heading information using a known reference (magnetic north). This is in contrast with gyros, which provide relative outputs that can accurately detect

how far a device has rotated. Additionally, the compass sensors are typically only used for rotational information around the Z or yaw axis, while gyros provide information around the X, Y, and Z axes (pitch, roll, and yaw).

State-of-the-art compass sensors include the Asahi Kasei Microsystems AK8973 and the Honeywell HMC5883. Both devices are triple-axis, digital-output devices, with the AK8973 in a 4x4x0.7mm package<sup>1</sup> and the HMC5883 in a 3x3x0.9mm package<sup>2</sup>. The AK8973 uses Hall sensors, while the HMC5883 uses AMR sensors.

### *Limitation of Magnetic Sensors*

Magnetic sensors respond to more than just the earth's magnetic field (typically ranging from 30 microteslas to over 60 microteslas).<sup>3</sup> They also respond to interference, such as RF signals (caused by cell phones, car engines, etc.) and to magnetic fields caused by magnets, such as those in TV and stereo speakers, cell phones, and headphones (Figure 7). Additionally, the earth's magnetic field is often distorted indoors by building materials containing iron, such as floor and wall beams. As a result, using a compass sensor to provide heading requires an algorithm that can compensate for the items referenced. Since in many instances the magnetic field can be assumed to be constant for a given location, the compass sensor may be used to provide a heading reference point, even if that reference is not truly north. Also since the compass responds to ambient noise as mentioned above, its output often must be put through a low-pass-filter to obtain an output free from high frequency noise interference. Thus compasses are often used in combination with gyroscopes, where the gyroscopes provide a heading signal for faster motions, and the filtered compass output provides a heading signal with a longer time constant to be used for bias and heading compensation. Additionally, since the earth's magnetic field is not perfectly parallel to the surface of the earth, its angle varies with position on the Earth, accelerometers are used in conjunction with compass sensors to provide tilt compensation.

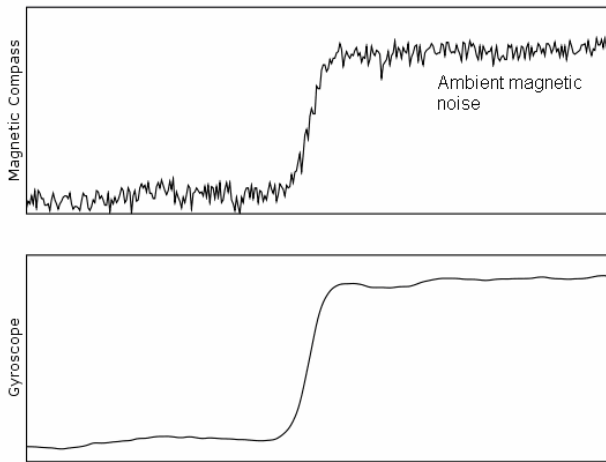

**Figure 7. Compass sensor vs. Gyroscope for sensing rotation about the yaw axis. Magnetic sensors respond to ambient magnetic noise, while gyroscopes do not. Thus compasses are often used in combination with gyroscopes, where the gyroscopes provide a heading signal for faster motions, and a filtered compass output is used to provide a heading signal with a longer time constant for bias and heading adjustment.**

**Complete 9-Axis MotionProcessing™ System**

At the heart of many motion-based designs is the combination of accelerometers, gyros, and compass

sensors. To help facilitate the design of systems incorporating motion-based sensors, InvenSense has created a reference board combining the ITG-3200 with a 3-axis accelerometer and a 3-axis electronic compass to provide a complete 9-axis design solution

**(Figure 8).** Schematics and gerber files are available to create modules to support USB-based Lithium-Ion battery charging and MCU flash programming, as well as Bluetooth RF. Running on an Atmel AVR XMEGA 8-bit microcontroller (MCU), this board is optimized to support sensor fusion using a 32K Byte flash image that enables air mouse support, data logging and a multi-function PC demo application to demonstrate functionality of the gyro, accelerometer and compass in any combination. The kit showcases the ITG-3200 and its advanced 16-bit analog-to-digital converters that provide wider system dynamic range than previously available for sensing both fast and slow motions accurately. This new reference design, combines InvenSense’s advanced *MotionProcessing* technology, in a very small battery powered form factor with RF capability, enables developers to quickly develop motion-enabled applications without needing to become motion physics experts. The modular design is small enough to be embedded into existing platforms, to quickly add motion enabled functionality (Figure 9).

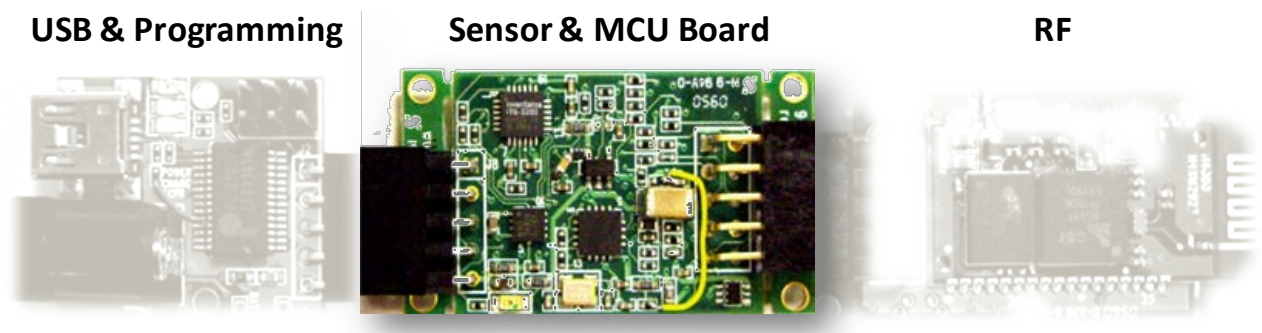

**Figure 8. InvenSense has created a 9-axis reference board that features the ITG-3200 triple-axis digital gyroscope with triple 16-bit ADCs and an I<sup>2</sup>C interface. It comes complete with 3-axis accelerometer, 3-axis compass sensor and Atmel 8-bit RISC MCU. Schematics and gerber files are available to produce a USB/battery charging/programming board and an RF board. Firmware is available for the reference solution. This modular design allows the sensor board to be embedded into an existing system alone or with one or both of the RF and the USB/programming boards.**



**Figure 9. The InvenSense 9-axis reference board (outlined in red) has been retrofitted into a standard RF 2-D mouse, adding air-mouse functionality to the device.**

**Global Positioning System**

Another common solution for determining position and heading is the global positioning system (GPS), which relies on satellite-based timing information to accurately determine position. GPS relies on line-of-sight communications with at least four satellites.<sup>4</sup> Consequently, it does not work properly when indoors or in urban environments where the view to the satellites may be obstructed, or where multipath conditions exist.

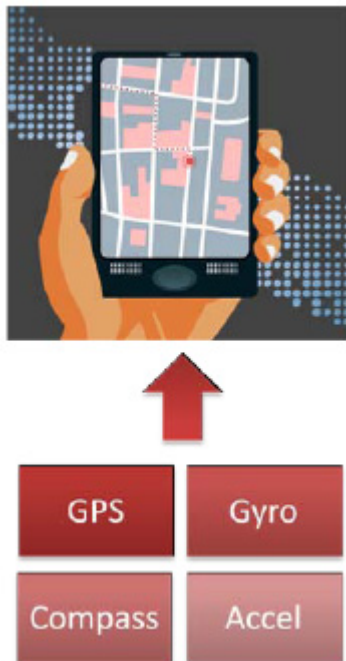

**Figure 10. Pedestrian Navigation Using GPS, gyro, accelerometer and compass**

In order to augment the GPS signal, gyroscope and compass sensors may be used to provide heading, and an accelerometer may be used for speed and distance

measurements. This may be useful in both vehicular and pedestrian navigation applications (Figure 10).

**Image Sensors**

Image sensors or camera sensors may be used to track motion, just as one’s eyes may be used for the same purpose. For example, in the Wii remote, a camera in the handheld remote, in conjunction with IR LEDs on a sensor bar, sense where a user is pointing relative to the TV screen (Figure 11).

**Limitations of Image Sensors**

Image sensors are limited by ambient lighting conditions (image sensors do not work properly with too much or too little light), their update rate (typically 15-60 frames per second), and viewing angle (they only can track motion when the item being tracked is in view of the sensor). These limitations are typically overcome by using other sensors, such as gyros and accelerometers to augment the information from the image sensor.

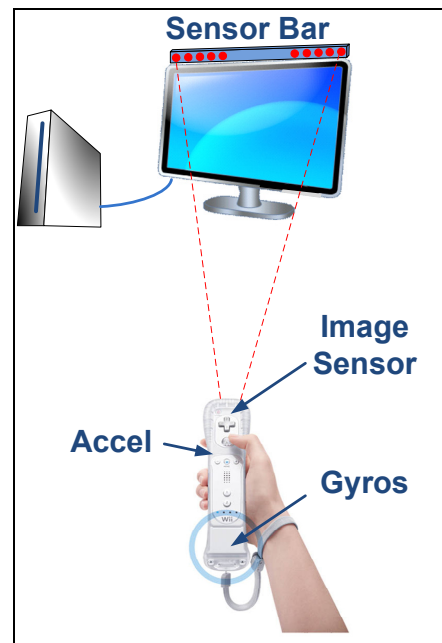

**Figure 11. In the Wii remote, an image sensor in conjunction with LEDs in the sensor bar is used to determine where a user is pointing in certain menu navigation applications.**

**Sensor combinations in existing consumer electronic devices**

Table 1. Shows the combination of sensors used in commercially-available electronic devices today, and proposes what sensors may be used in these applications in the future.

**Table 1. Common sensor arrangements in consumer electronics, showing future trends**

Equipment	Common Sensors Today	Possible Future Additions	Notes
<b>Game controllers</b>	Accelerometers, gyros, image sensors	Compass sensors	Compass sensors provide for yaw compensation and for absolute heading
<b>Remote controls</b>	None	Accelerometers, gyros, and compass sensors	Accelerometers and gyros allow for gesture shortcuts, game control, and motion-based menu/Internet navigation for connected DTVs. The addition of compass sensors provides absolute heading.
<b>Smartphones</b>	Accelerometers, Compass, Cameras, GPS	Gyros	Gyros enable improved gaming, camera image stabilization, location based services, motion-based user interface and gesture short cuts, motion authentication, and augmented reality.
<b>Digital cameras</b>	Gyros	Accelerometers, compass, GPS	Gyros today allow for image stabilization. The addition of accelerometers, compass, and GPS allow for position and heading data to be included with photos. Also enables motion-based user interface and gesture short cuts.
<b>Sports equipment</b>	Accelerometers	Gyros	Accelerometers are used for pedometer function. Adding gyros allows for true 3-D motion tracking, which can be useful for evaluating trajectories of balls, racket swings, body movement, etc.

**Summary**

Consumer grade MEMS rate gyroscopes and accelerometers have advanced to the point where they are becoming easily integrated into consumer electronics devices. As a result, motion processing solutions have become the next “must have” function, allowing OEMs to differentiate their products by adding new capabilities for device interaction and control.

In order to design a motion-enabled system, an understanding of various motion sensors and their fundamentals are required. This paper reviewed the use of common sensor types and how these sensors are combined in a complementary way to overcome their individual limitations. In addition to accelerometers and gyros, other common sensing elements covered in this paper were compass sensors, image sensors, and GPS.

Various applications were reviewed as was a complete reference design that can be used by developers for creating portable, wirelessly-connected, electronic devices incorporating motion-based sensors. Over time, these sensors will become increasingly integrated, further reducing implementation costs. The design considerations detailed here will assist engineers in creating an optimized motion processing solution accelerating adoption into consumer electronics devices.

To request additional information please go to [www.invensense.com/mems/requestform.html](http://www.invensense.com/mems/requestform.html)

## References

1. ic-on-line.cn ([http://www.ic-on-line.cn/iol/datasheet/ak8973\\_4138699.pdf](http://www.ic-on-line.cn/iol/datasheet/ak8973_4138699.pdf))
2. ssec.honeywell.com (<http://www.ssec.honeywell.com/magnetic/datasheets/HMC5843.pdf>)
3. "Earth's magnetic field", Wikipedia, ("[http://en.wikipedia.org/wiki/Earth's\\_magnetic\\_field](http://en.wikipedia.org/wiki/Earth's_magnetic_field)")
4. "Global Positioning System", Wikipedia, ([http://en.wikipedia.org/wiki/Global\\_Positioning\\_System](http://en.wikipedia.org/wiki/Global_Positioning_System))
5. "Selection and Integration of MEMS-Based Motion Processing"; Nasiri, Sachs, and Maia; <http://invensense.com/mems/gyro/documents/whitepapers/Selection-and-integration-of-MEMS-based-motion-processing-in-consumer-apps-070809-EE-Times.pdf>
6. "Motion Sensors Gaining Inertia with Popular Consumer Electronics"; Daniel Goehl and David Sachs, [http://invensense.com/mems/gyro/documents/whitepapers/GyroAccel\\_WhitePaper.pdf](http://invensense.com/mems/gyro/documents/whitepapers/GyroAccel_WhitePaper.pdf)
7. "A Critical Review of MEMS Gyroscopes Technology and Commercialization Status", Nasiri, <http://invensense.com/mems/gyro/documents/whitepapers/MEMSGyroComp.pdf>
8. "IMU Arrays: The Biomechanics of Baseball Pitching"; Berkson, Aylward, Zachazewski, Paradiso, and Gill; <http://www.media.mit.edu/resenv/pubs/papers/2006-06-IMU-Baseball.pdf>
9. "Cyber-shot Digital Camera HX5V/B", Sonystyle.com (<http://www.sonystyle.com/webapp/wcs/stores/servlet/ProductDisplay?catalogId=10551&storeId=10151&langId=-1&productId=8198552921666077169>)
10. "Runners get iPod virtual trainer", 8/7/2006, EETimes.com (<http://eetimes.com/rss/showArticle.jhtml?articleID=191601142>)

## Authors' Bios

Doug Vargha is Director of Marketing for the Gaming and 3D User Interface Business Unit at InvenSense.

Michael Maia is Vice President and General Manager of the Gaming and 3D User Interface Business Unit at InvenSense.

###